

SK-02 Cable Force Transducer

FEATURES

- Suitable for cable diameters of 8 mm to 22 mm
- Sealed force detector with 350 Ω strain gauges
- Specially designed for retrofitting in existing crane equipment
- Bronze supports allow smooth mechanical cable guidance
- IP 65 protection class
- Stainless steel construction
- Quick and easy installation
- Easy to mount directly on fixed point of cable
- Reliable and economical

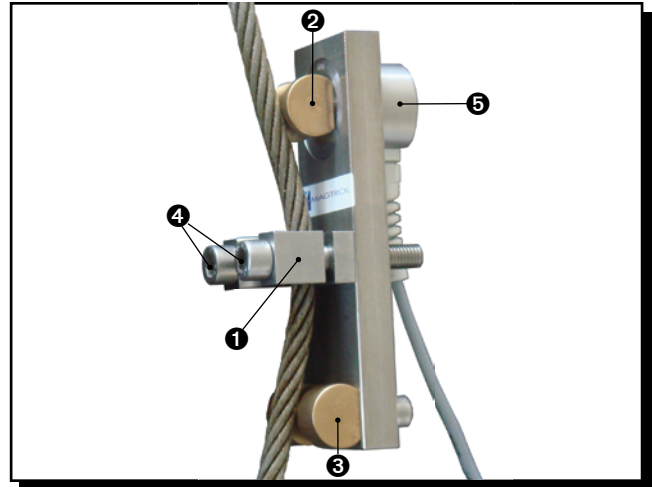

DESCRIPTION

The Magtrol SK-02 Cable Force Transducer is mounted to a cable by a clamp ① with two screws ④. The cable is gently bent over two bronze supports with rounded bearing surfaces ②③.

Force (P1) acting on the support ② is measured by the force detector ⑤ and is directly and linearly proportional to the force in the cable (P).

APPLICATIONS

The SK-02 is perfectly suited for hoisting and crane security in combination with a Magtrol LMU Load Monitoring Unit or AN Series Load Monitor/Signal Conditioner/Display.

SPECIFICATIONS

MECHANICAL CHARACTERISTICS *		
Cable Diameter	Min. Nominal Load	Max. Nominal Load
8 mm – 11 mm	8 kN	15 kN
12 mm – 16 mm	15 kN	30 kN
17 mm – 22 mm	30 kN	50 kN
ELECTRICAL CHARACTERISTICS		
Nominal Sensitivity	1 mV/V – 2 mV/V for 1/5 of the overload at rupture (depending on cable diameter)	
Supply Voltage	5 V – 10 V	
CONNECTION CABLE		
Shielded Cable Length	3 m	
Pin Connections:	Color Code (according to DIN):	
supply (+)	brown	
supply (-)	yellow	
signal (+)	white	
signal (-)	green	

* Loads are valid for standard crane cables with 180 kg/mm² galvanized steel wire. Specifications may differ with other types of cables.

SYSTEM CONFIGURATION OPTIONS

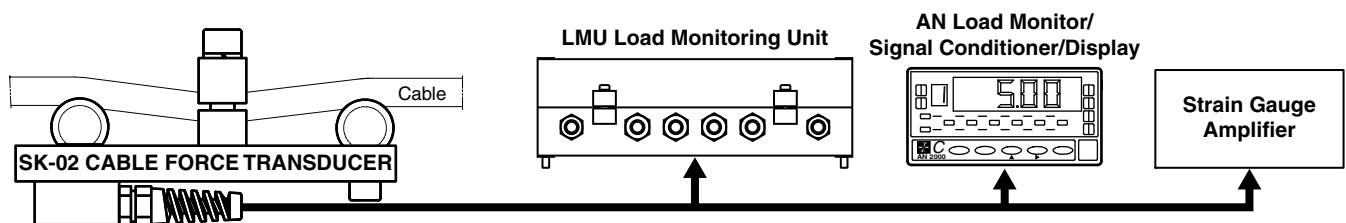

Drawing not to scale

TRANSDUCER DIMENSIONS

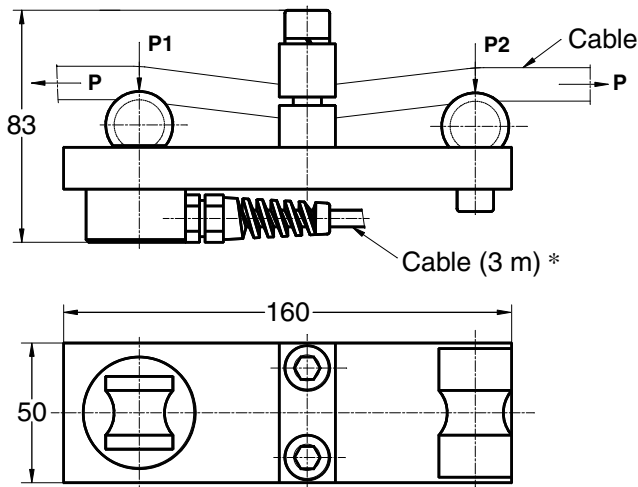

* Shielded connection cable not attached to transducer body: allows mounting of the transducer without interruption of the cable

CABLE MOUNTING

Fastening torque: 30 N·m

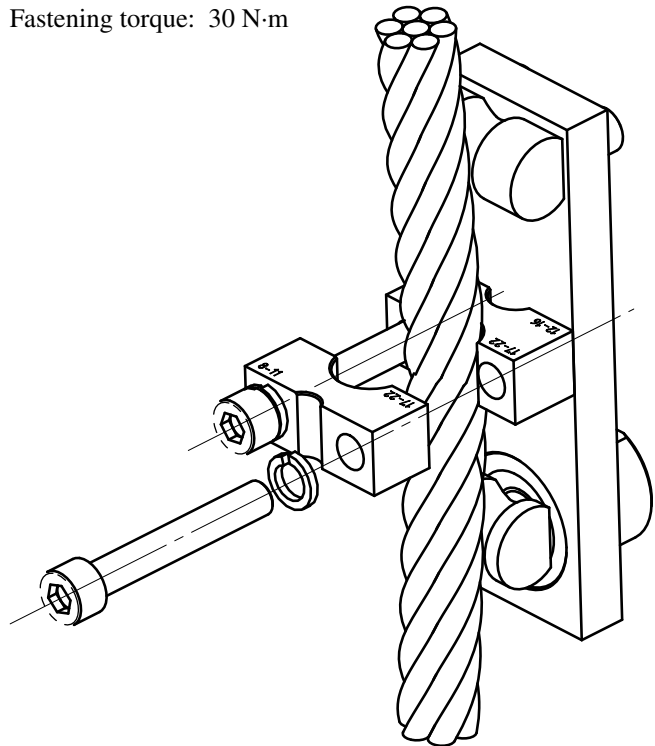

CLAMP CONFIGURATIONS

Clamp positions are based on the cable diameter. For example, if the cable diameter is between 12 mm and 16 mm, the clamps must be mounted according to the middle drawing.

Cable Diameter: 8 mm to 11 mm

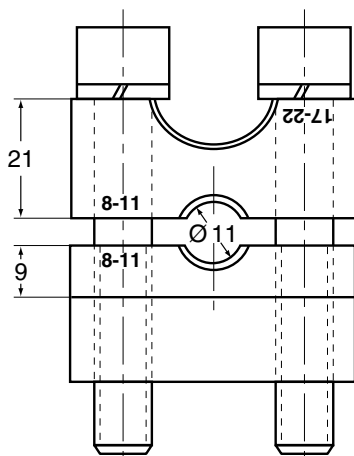

Cable Diameter: 12 mm to 16 mm

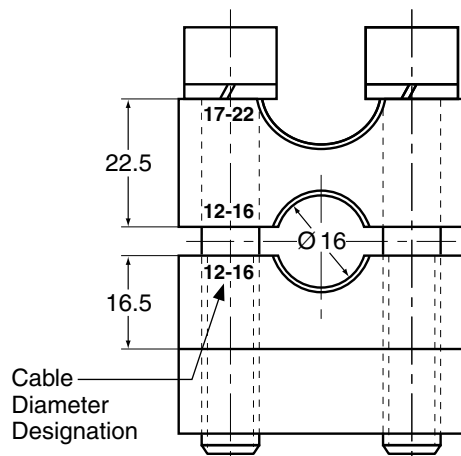

Cable Diameter: 17 mm to 22 mm

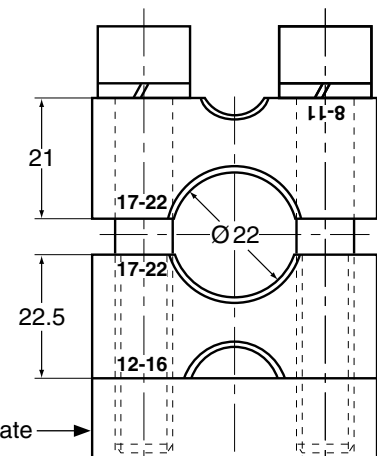

Due to the continual development of our products, we reserve the right to modify specifications without forewarning.



www.magtrol.com

MAGTROL INC

70 Gardenville Parkway
Buffalo, New York 14224 USA
Phone: +1 716 668 5555
Fax: +1 716 668 8705
E-mail: magtrol@magtrol.com

MAGTROL SA

Centre technologique Montena
1728 Rossens/Fribourg, Switzerland
Phone: +41 (0)26 407 3000
Fax: +41 (0)26 407 3001
E-mail: magtrol@magtrol.ch

Subsidiaries in:

Great Britain
Germany • France
China • India
Worldwide Network
of Sales Agents

