

## optoNCDT 1700DR Designed for use with direct reflective materials

optoNCDT 1700DR is designed for use with direct reflective materials, such as mirrored surfaces that are traditionally difficult to measure with laser technology. The sensor compensates for the high intensity of the reflected light by using patented, high speed software algorithms that dramatically reduce signal noise. The unit size is identical to the standard optoNCDT 1700 series and is therefore ideal for use in small areas (mounting device included).

Model	ILD1700-2DR	ILD1700-10DR	ILD1700-20DR	
Measuring range	2mm	10mm	20mm	
Start, mid, end of measuring range	see engineering drawing			
Linearity	2 $\mu$ m	10 $\mu$ m	40 $\mu$ m	
	$\leq 0.1\%$ FSO		$\leq 0.2\%$ FSO	
Resolution (at 2.5kHz without averaging)	0.1 $\mu$ m	0.5 $\mu$ m	3 $\mu$ m	
Measuring rate	2.5kHz / 1.25kHz / 625Hz / 312.5Hz (adjustable)			
Light source	semiconductor laser < 1mW, 670nm (red)			
Permissible ambient light	10,000lx (at 2.5kHz)			
Laser safety class	class 2 acc. DIN EN 60825-1 : 2001-11			
Spot diameter	SMR	80 $\mu$ m	110 $\mu$ m	320 $\mu$ m
	MMR	35 $\mu$ m	50 $\mu$ m	45 $\mu$ m
	EMR	80 $\mu$ m	110 $\mu$ m	320 $\mu$ m
Temperature stability	0.025 % FSO/°C	0.01 % FSO/°C (based on digital output)		
Operation temperature	0 ... +50°C			
Storage temperature	-20 ... +70°C			
Output	measurements	selectable: 4 ... 20mA / 0 ... 10V / RS 422 / USB (option with cable PC1700-3/USB)		
	switching outputs	1 x error or 2 x limit (each programmable)		
Switch input	laser ON-OFF / zero			
Operation	via touch screen on sensor or via PC with ILD 1700 tool			
Power supply	24VDC (11 ... 30VDC), max. 150mA			
Electromagnetic compatibility (EMC)	EN 61000-6-3; EN 61000-6-2			
Sensor cable length (with connector)	0.25m (integrated cable with connector) option: 3m or 10m			
Synchronisation	possible for simultaneous or alternating measurements			
Protection class	IP 65			
Vibration	2g / 20 ... 500Hz			
Shock	15g / 6ms			
Weight (with 0.25m cable)	~ 550g			

FSO = Full Scale Output All specifications are valid for polished and planar surfaces.  
SMR = Start of measuring range MMR = Midrange EMR = End of measuring range

# optoNCDT 1700DR Dimensions and Accessories

**optoNCDT 1700-2DR**

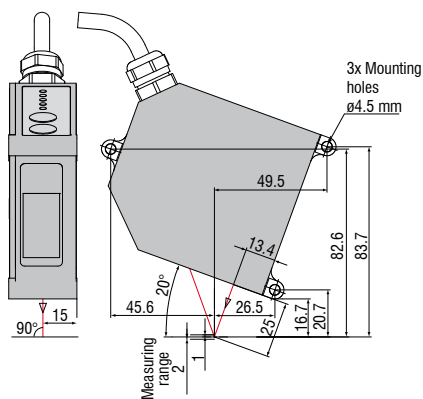

**optoNCDT 1700-10DR**

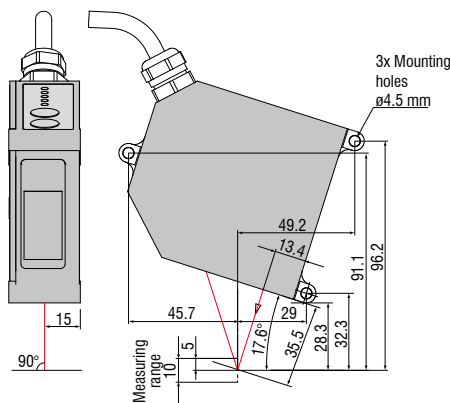

**optoNCDT 1700-20DR**

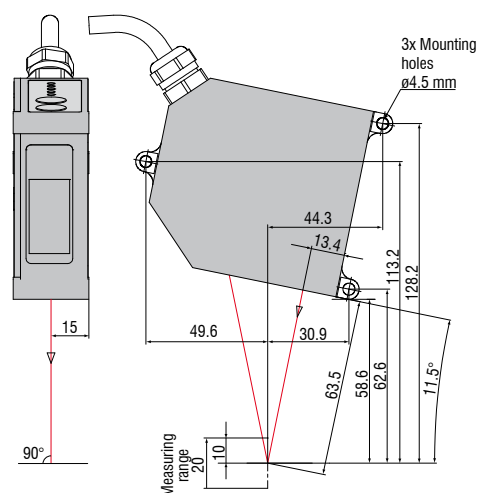

(Dimensions in mm, not to scale. All CAD files are available online.)

**Mounting direct reflection**  
(tilt <math>< 0.1^\circ</math>)

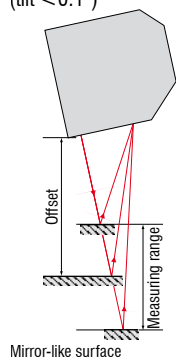

**Precision alignment accessory**

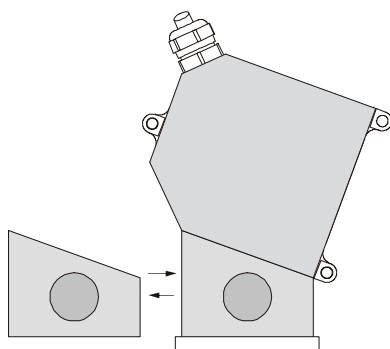

Mounting device included with delivery.

**Accessories optoNCDT 1700DR**

Supply and output cable

- PC 1700-3 (3 m)
- PC 1700-10 (10 m)
- PC 1700-10/3/IF2004 (10 m, for use with interface-card IF2004)
- PC 1700-10/D-Sub/9-pol.
- PC 1700-3/3/USB/BNC/US (power supply converter)
- PC 1700-3/USB (3 m, with USB-RS422-converter, supply 90 ... 230 VAC)
- PC1700-3/3/USB/OE/US (3 m, with USB-RS422-converter, supply 90 ... 230 VAC)

Power supply

- PS 2010 (for top-hat rail mounting; L/W/H 120x120x40 mm)
- Input 115 / 230 VAC selectable; output 24 VDC / 2.5 A)

Interface-card

- IF2004 (RS422 PCI-interface-card for PC for 1-4 sensors optoNCDT or 3 sensors and 1 encoder)

External Trigger

- Triggerbox 1700 (Electronics for triggering optoNCDT 1700 sensors. Acceptable trigger levels are from +2.4 VDC to +24 VDC, L/W/H 98x64x34 mm)

Display

- CSP301 (digital processing and readout unit, programmable for two analog outputs)

**Micro-Epsilon**

info@micro-epsilon.com  
www.micro-epsilon.com

info@micro-epsilon.co.uk  
www.micro-epsilon.co.uk

info@micro-epsilon.us  
www.micro-epsilon.us

certified DIN EN ISO 9001 : 2000  
modifications reserved / Y9761209-A020098DGO

