



## Instruction manual crm+ Ultrasonic Sensors with one switched output

crm+25/D/TC/E  
crm+35/D/TC/E  
crm+130/D/TC/E  
crm+340/D/TC/E  
crm+600/D/TC/E

### Product description

- The crm+sensor with one switched output measures the distance to an object within the detection zone contactless. Depending on the adjusted detect distance the switched output is set.
- The ultrasonic transducer surface of the crm+ sensors is laminated with a PEEK film. The transducer itself is sealed against the housing by a PTFE joint ring. This composition ensures a high resistance against many aggressive substances.
- All settings are done with two push-buttons and a three-digit LED-display (TouchControl).
- Light emitting diodes (three-colour LEDs) indicate the switching status.
- The output functions are changeable from NOC to NCC.
- The sensors are adjustable manually using the numerical LED-display or may be trained using Teach-in processes.
- Useful additional functions are set in the Add-on-menu.
- Using the LinkControl adapter (optional accessory) all TouchControl and additional sensor parameter settings may be made by a Windows-Software.

### Safety Notes

- Read the operating instructions prior to start-up.
- Connection, installation and adjustment works may only be carried out by expert personnel.
- No safety component in accordance with the EU Machine Directive.

The crm+ sensors indicate a blind zone, in which the distance cannot be measured. The operating range indicates the distance of the sensor that can be applied with normal reflectors with sufficient function reserve. When using good reflectors, such as a calm water surface, the sensor can also be used up to its maximum range. Objects that strongly absorb (e.g. plastic foam) or diffusely reflect sound (e.g. pebble stones) can also reduce the defined operating range.

### Synchronisation

If the assembly distances shown in Fig.1 for two or more sensors are exceeded the integrated synchronisation should be used. Connect Sync/Com-channels (pin 5 at the units receptacle) of all sensors (10 maximum).

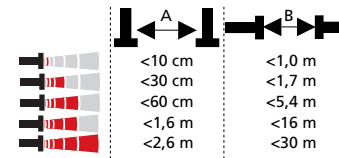

Fig. 1: Assembly distances, indicating synchronisation/multiplex

### Multiplex mode

The Add-on-menu allows to assign an individual address »01« to »10« to each sensor connected via the Sync/Com-channel (Pin5). The sensors perform the ultrasonic measurement sequentially from low to high address. Therefore any influence between the sensors is rejected.

The address »00« is reserved to synchronisation mode and deactivates the multiplex

mode. (To use synchronised mode all sensors must be set to address »00«.)

### Assembly instructions

- Assemble the sensor at the installation location.
- Plug in the connector cable to the M 12 connector.

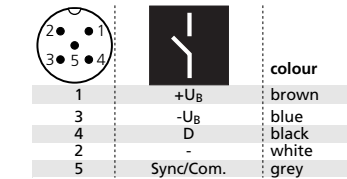

Fig. 2: Pin assignment with view onto sensor plug and colour coding of the microsonic connection cable

### Start-up

crm+ sensors are delivered factory made with the following settings:

- Switched output on NOC
- Detecting distance at operating range

- Measurement range set to maximum range

Set the parameters of the sensor manually or use the Teach-in procedure to adjust the detect points.

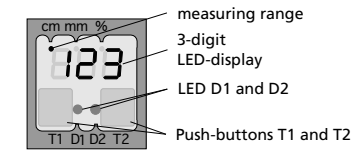

Fig. 3: TouchControl

### Operation

crm+ sensors work maintenance free. Small amounts of dirt on the surface do not influence function. Thick layers of dirt and caked-on dirt affect sensor function and therefore must be removed.

### Note

- As a result of the design the assembly of PEEK film and PTFE joint ring is not gas-proof.
- The chemical resistance has to be tested experimentally if necessary.
- crm+ sensors have internal temperature compensation. Because the sensors heat up on their own, the temperature compensation reaches its optimum working point after approx. 30 minutes of operation.
- During normal mode operation, a yellow LED D2 signals that the switched output has connected.
- During normal mode operation, the measured distance value is displayed on the LED-indicator in mm (up to 999 mm) or cm (from 100 cm). Scale switches automatically and is indicated by a point on top of the digits.
- During Teach-in mode, the hysteresis loops are set back to factory settings.
- If no objects are placed within the detection zone the LED-indicator shows »- - -«.
- If no push-buttons are pressed for 20 seconds during parameter setting mode the made changes are stored and the sensor returns to normal mode operation.
- You can lock the key pad to provide inputs, see »Key lock and factory setting«.
- You can reset the factory settings at any time, see »Key lock and factory setting«.

### Show parameters

Tapping push-button T1 shortly during normal mode operation shows »PAR« on the LED-display. Each time you tap push-button T1 the actual settings of the switched output are shown.

## Set sensor parameters alternatively numerically using LED-display...

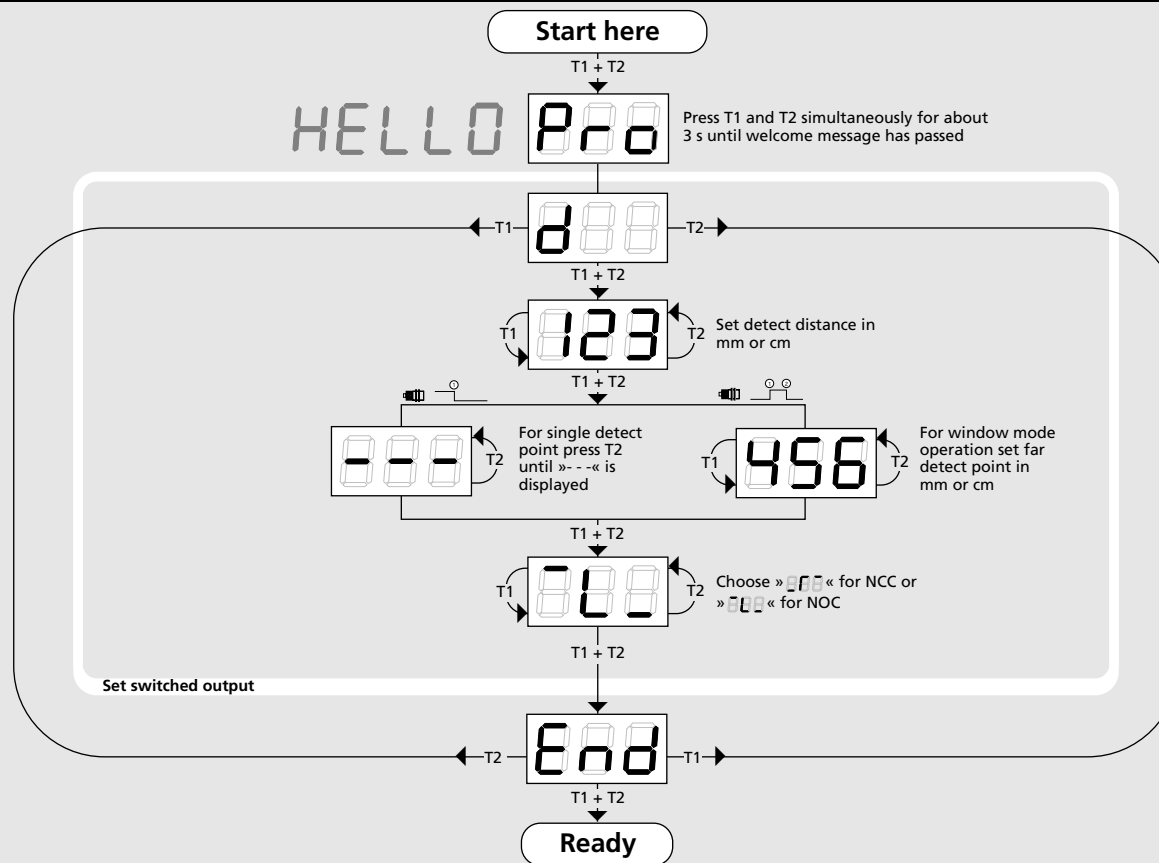

## ...or with the Teach-in procedure

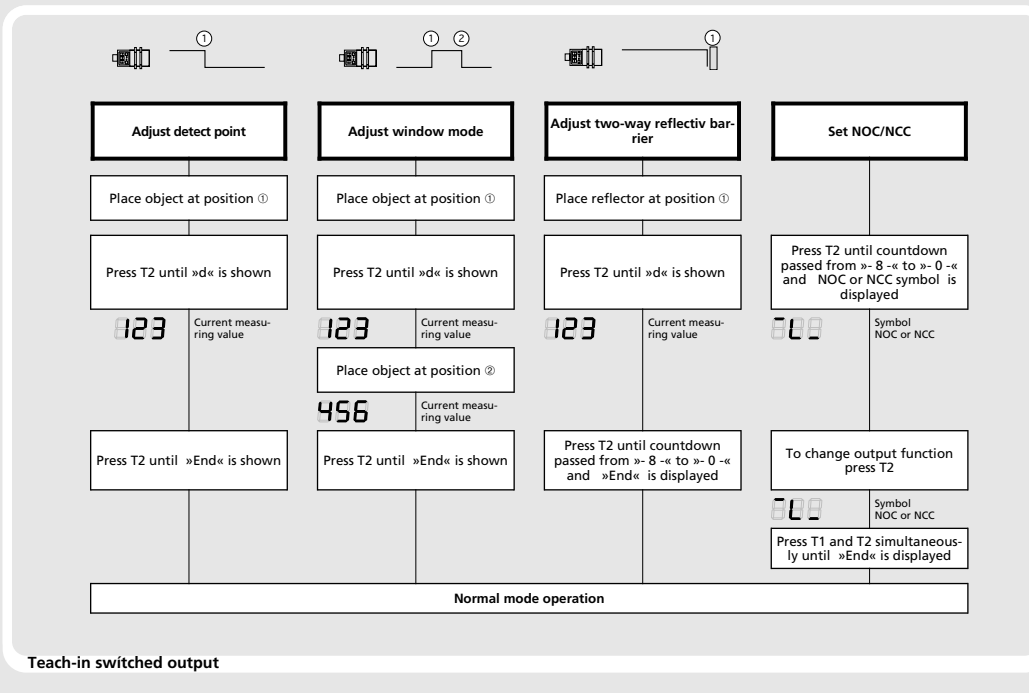

## Key lock and factory setting

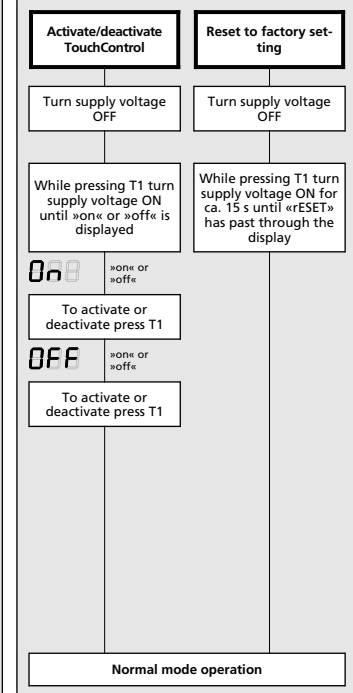

## Usefull additional functions in Add-on menu (for experienced users only, settings not required for standard applications)

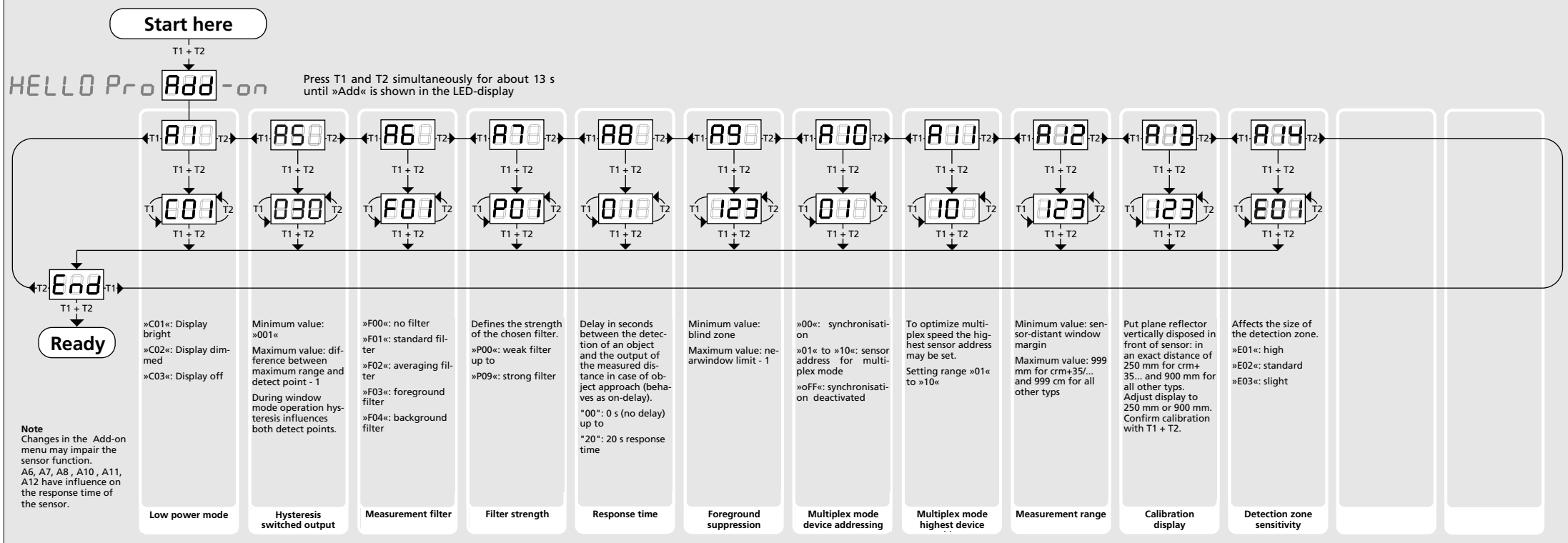

# Technical data

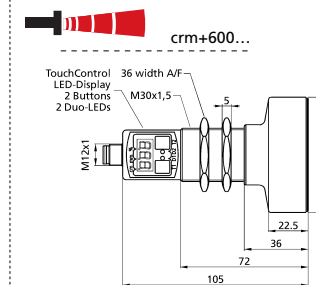
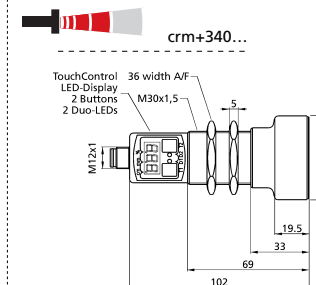
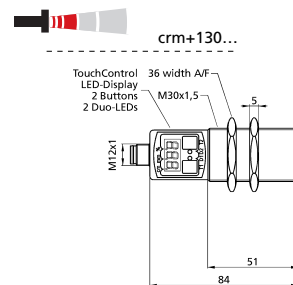
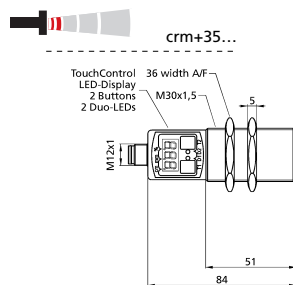
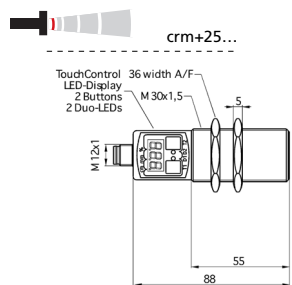
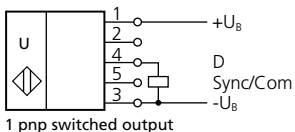

<b>Blind zone</b>	0 to 30 mm	0 to 85 mm	0 to 200 mm	0 to 350 mm	0 to 600 mm
<b>Operating range</b>	250 mm	350 mm	1.300 mm	3.400 mm	6.000 mm
<b>Maximum range</b>	350 mm	600 mm	2.000 mm	5.000 mm	8.000 mm
<b>Angle of beam spread</b>	Please see detection zone				
<b>Transducer frequency</b>	ca. 320 kHz				
<b>Resolution, sampling rate</b>	0,18 mm				
<b>Reproducibility</b>	± 0,15 %				
<b>Accuracy</b>	Temperature drift internal compensated, ≤ 2 % may be deactivated <sup>1)</sup> (0,17%/K without compensation)				

**Detection zones for different objects**  
The dark grey areas are determined with a thin round bar (10 or 27 mm dia.) and indicate the typical operating range of a sensor. In order to obtain the light grey areas, a plate (500 x 500 mm) is introduced into the beam spread from the side. In doing so, the optimum angle between plate and sensor is always employed. This therefore indicates the maximum detection zone of the sensor. It is not possible to evaluate ultrasonic reflections outside this area.

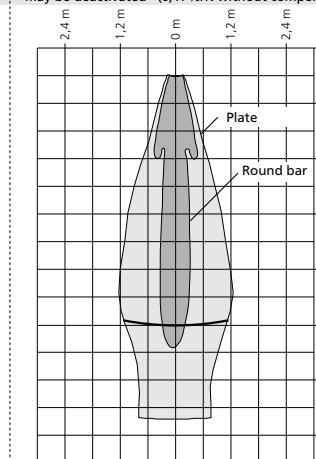
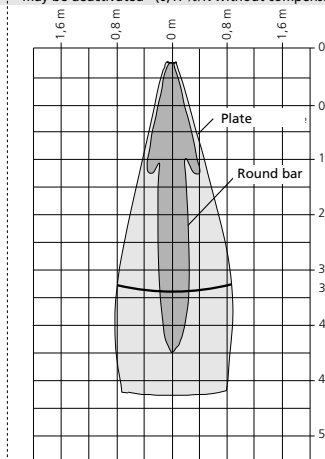
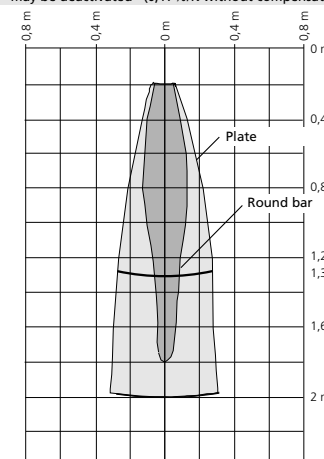
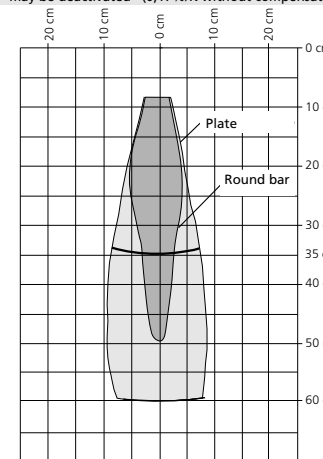
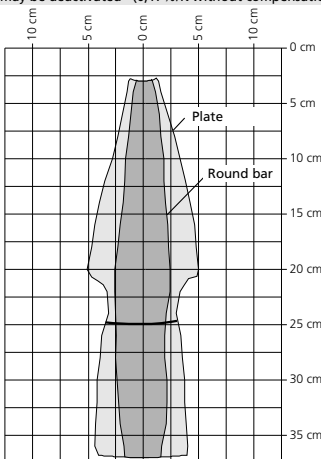

<b>Operating voltage <math>U_B</math></b>	9 V to 30 V DC, reverse polarity protection	9 V to 30 V DC, reverse polarity protection	9 V to 30 V DC, reverse polarity protection	9 V to 30 V DC, reverse polarity protection	9 V to 30 V DC, reverse polarity protection
<b>Voltage ripple</b>	±10 %	±10 %	±10 %	±10 %	±10 %
<b>No-load supply current</b>	≤ 80 mA	≤ 80 mA	≤ 80 mA	≤ 80 mA	≤ 80 mA
<b>Housing</b>	Stainless steel 1.4571, plastic parts: PBT, TPU; Ultrasonic transducer: PEEK film, PTFE				
<b>Class of protection to EN 60529</b>	IP 67				
<b>Norm conformity</b>	EN 60947-5-2				
<b>Type of connection</b>	5-pin initiator plug, PBT				
<b>Controls</b>	2 push-buttons (TouchControl)				
<b>Indicators</b>	3-digit LED-display, 2 three-colour LEDs				
<b>Programmable</b>	Yes, with TouchControl and LinkControl				
<b>Operating temperature</b>	-25°C to +70°C				
<b>Storage temperature</b>	-40°C to +85°C				
<b>Weight</b>	150 g	150 g	150 g	210 g	270 g
<b>Switching hysteresis<sup>1)</sup></b>	3 mm	5 mm	20 mm	50 mm	100 mm
<b>switching frequency<sup>1)</sup></b>	11 Hz	8 Hz	6 Hz	3 Hz	2 Hz
<b>Response time<sup>1)</sup></b>	50 ms	70 ms	110 ms	180 ms	240 ms
<b>Time delay before availability</b>	< 300 ms				
<b>Order No.</b>	crm+25/D/TC/E	crm+35/D/TC	crm+130/D/TC	crm+340/D/TC	crm+600/D/TC
<b>Switched output</b>	pnp, $U_B$ - 2 V, $I_{max}$ = 200 mA switchable NOC/NCC, short-circuit-proof				

1) Can be programmed with TouchControl and LinkControl