

» AM4901 «

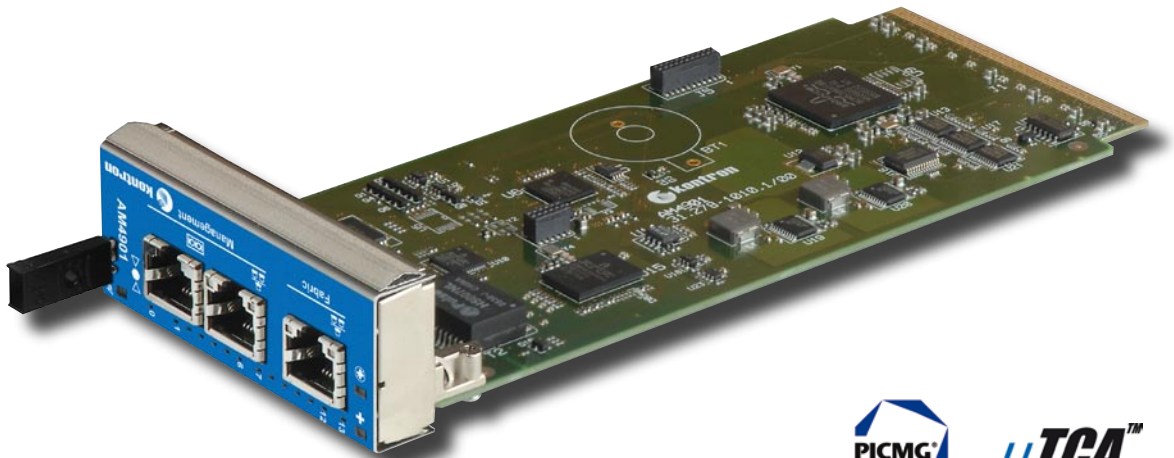

Cost optimized MicroTCA Carrier Hub (MCH) enables applications outside of telecommunications segment

- » Cost optimized design by focusing to essential requirements
- » System management + Ethernet Switching
- » Supports up to 12 AMCs, 2 cooling units and 4 power modules
- » Front panel GbE uplink and management port
- » MCH update and cross-over Channel

AM4901 MCH for cost optimized MicroTCA solutions

No-frills approach, still providing the essential features

The two main functions of an MCH are system management (i.e. IPMI controlled power management, electronic keying, hot-swap of AMCs) and Ethernet switching. The AM4901 provides those functions for up to 12 AMCs, 2 cooling units and 4 power modules. Unlike in the telecommunication segment, where advanced feature sets require managed switches with complex control software, such features are not required in most industrial applications. The AM4901 contains an unmanaged BCM5396 Ethernet switch, which allows to simplify the design and to improve costs (lower cost components, no switch controller, no software for switch controller).

Among the typical applications are image processing in the industrial environment or medical environment, industrial control systems, information systems for trains and simple communication systems without the need for managed switches.

The AM4901 is a single PCB solution with one MCH tongue only. It provides one GbE uplink on front, and on the edge connector 12x GbE for AMCs (Fabric [A]) plus 1x GbE for

the MCH update channel. In addition to the standard LED indicators, there are status LEDs for 13 GbE ports (Fabric [A] and MCH update channel) on the front, as well as RJ45 connectors for one management interface and one serial interface to access the management controller (MCMC). For management functions the AM4901 contains a MCMC LPC2368 with Kontron's own IPMI software. The MCH supports IPMB-L links to up to 12 AMCs, I2C to the EEPROM on the backplane, and I2C as well as IPMB-0 [A:B] links for power management and cooling. A JTAG connection is also provided.

The AM4901 represents a MicroTCA compliant MCH with a cost improved design. It supports the Kontron family of cost optimized MicroTCA platforms, as well as a range of other 3rd party platforms. The AM4901 helps customers to address with MicroTCA a broader range of applications. The choice of the AM4901 is a perfect fit for designing a complete and highly versatile MicroTCA platform that is cost-effective by focusing to the application needs.

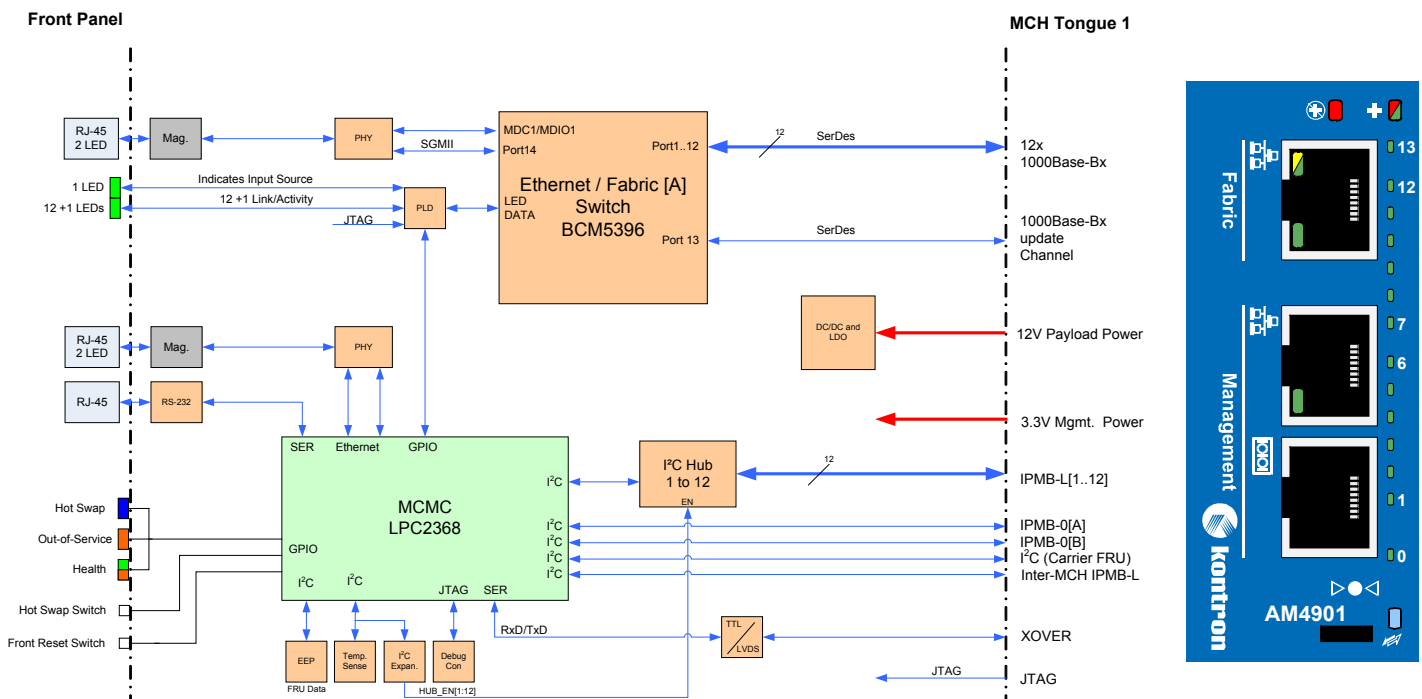

Technical Information

MCMC

NXP® LPC2368 microcontroller

16-bit / 32-bit, 70 MHz ARM7 CPU
 512 kB Flash
 58 kB SRAM
 One Ethernet connection to the management uplink port on the front panel via Remote Monitoring and Control Protocol (RMCP)
 IPMI
 Watchdog timer
 I²C busses for IPMB usage
 Command line interface

Ethernet Switch

Broadcom BCM5396 Gigabit Ethernet switch

16 SerDes / SGMII ports, only 14 ports are used on the AM4901:
 12 ports connected to the Fabric [A]
 1 port connected to the MCH update channel
 1 port connected to the uplink port on the front panel
 Non-blocking
 Low latency
 Unmanaged layer 2 switch
 Automatic address learning and aging
 256 kB on-chip packet buffer

System Interconnect

Gigabit Ethernet

12x 1000BASE-BX (SerDes) on Fabric[A]
 1x 1000BASE-BX (SerDes) on MCH update Channel

I2C

12x IPMB-L to AMC Modules
 2x IPMB-0 [A:B] redundant to Power Modules and Cooling Units
 1x IPMB-L inter-MCH
 1x I2C to carrier FRU

Front Interfaces

Gigabit Ethernet

One 1000BASE-T on RJ-45 connector

Ethernet

One 10BASE-TX on RJ-45 connector

Serial Port

One terminal port with RS-232 signaling on an RJ-45 connector

Reset

One reset switch

LEDs

12 Link LEDs (green) for each port on the Fabric[A]
 1 Link LED (green) for the MCH update Channel
 1 LED (green) for control purchase
 4 bicolor (red / green) LEDs to indicate system states
 3 AMC management LEDs (Hot Swap, Out-of-Service, Health)

Compliance

MicroTCA

PICMG MTCA.0 Micro Telecommunications Comp. Architecture R1.0

CE

EN55022, EN55024, EN61000-6-2/-6-3, EN300386, EN60950-1

Vibration/Shock

IEC60068-2-6 / IEC60068-2-27

WEEE

Directive 2002/96/EC

RoHS

Directive 2002/95/E

Environmental

Temperature Range

Operational: -5 °C to +55 °C
 Storage: -40 °C to +70 °C
 no module heat sink, forced system airflow

Humidity

93% RH at 40°C, non-condensing

Vibration (operating)

5-150 [Hz] frequency range
 1 [g] acceleration
 1 [oct/min] sweep rate
 10 sweeps/axis
 3 directions: x,y,z

Shock (operating)

15 [g] acceleration
 11 [ms] pulse duration
 3 shocks per direction
 5 [s] recovery time
 6 directions, ±x, ±y, ±z

Technical Information

Misc

Dimensions	Single, Full-Size MCH module
	181.5 mm x 73.5 mm x 28.95 mm
Power Supply	12 V Payload Power, 3.3 V Management Power
Power Consumption	Typ. 5W
Board Weight	100 grams
MTBF	tbd acc. Bellcore Issue 6, Ground Benign, Controlled, 30 C

Ordering Information

Article	Description
AM4901	MCH with unmanaged GbE switch for 12 AMCs

AM9401 PLATFORMS

OM6062



OM6040



CORPORATE OFFICES

Europe, Middle East & Africa

Oskar-von-Miller-Str. 1
85386 Eching/Munich
Germany

Tel.: +49 (0)8165/ 77 777
Fax: +49 (0)8165/ 77 279
info@kontron.com

North America

14118 Stowe Drive
Poway, CA 92064-7147
USA

Tel.: +1 888 294 4558
Fax: +1 858 677 0898
info@us.kontron.com

Asia Pacific

17 Building, Block #1, ABP.
188 Southern West 4th Ring Road
Beijing 100070, P.R.China

Tel.: + 86 10 63751188
Fax: + 86 10 83682438
info@kontron.cn

