

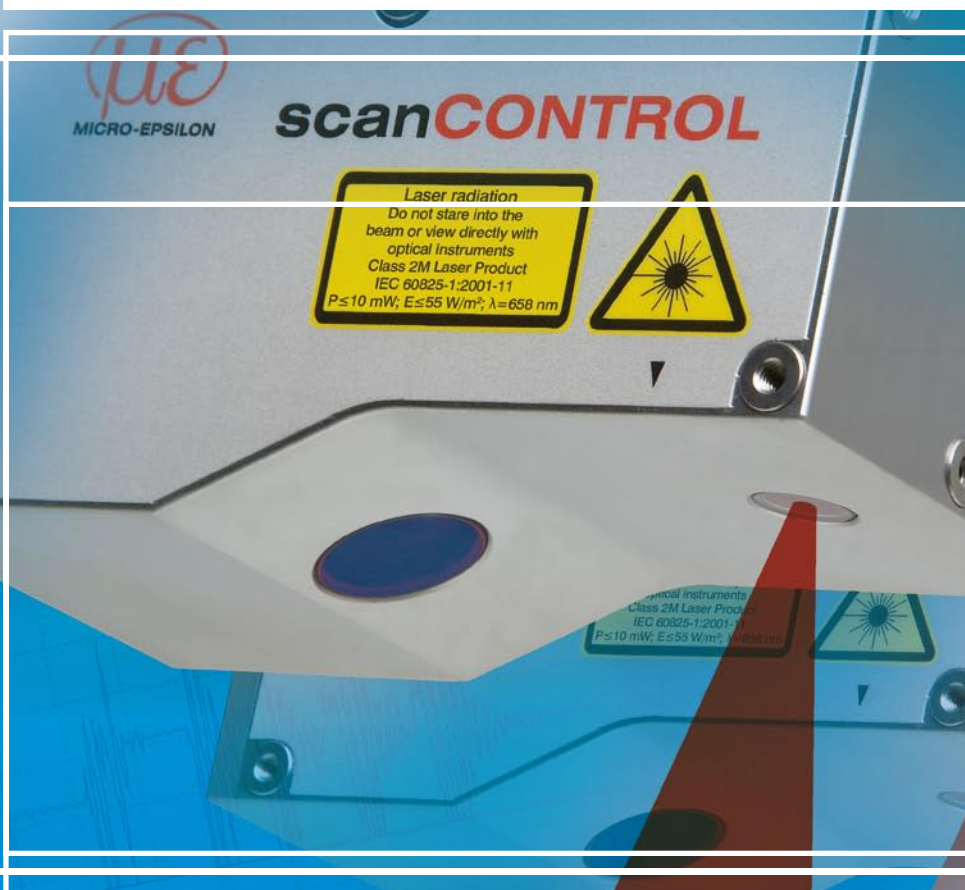

More Precision.

scanCONTROL 2700

Compact 2D/3D profile sensor with integrated controller





- Compact design with integrated controller
- 64,000 data points per second
- 100Hz profile frequency at full resolution
- Large stand off
- Real time capability with synchronisation for multiple scanners
- Excellent price/performance ratio
- Calibrated 3D data and intensity image

Measuring principle

The scanCONTROL 2700 laser line scanner uses the triangulation principle for a two dimensional acquisition of a height profile of various target surfaces. By using special lenses, a laser line is generated and projected onto the target surface. A high-quality optical system projects the diffusely reflected light of this laser line back onto a highly sensitive sensor matrix. In addition to the calibrated distance information (z-axis), the controller, integrated into the sensor head, uses this matrix image to calculate the position along the laser line (x-axis). This generates calibrated matched measurement values (z, x) which are then output as a precise line profile. Regardless of the position or angle the profile data are absolute calibrated data sets in a two-dimensional coordinate system that is fixed in respect to the sensor. By moving the object or traversing the sensor, it is possible to obtain a precise three dimensional image of your target as well as an intensity image at the same time.

Compact concept with integrated controller

The scanCONTROL 2700 combines technology and performance in one device offering an integrated solution with no external controller with the smallest and most compact design possible. The wiring of this device can be kept at a minimum since the power can be supplied via the FireWire IEEE1394a interface. This is a real advantage for applications with multiple sensors or in case the sensor needs to be mounted on a moving platform.

Real time measurement

The important parameters for a point sensor are the measuring frequency and the point resolution. In case of a laser line scanner the number of pixels is an additional key specification, therefore all these parameters are important specifications which have to be considered for each application. In addition to the profile resolution (measurement points along the laser line) the data rate or frame rate is the most important parameter. The profile sensor scanCONTROL 2700 series delivers 64,000 points per second or 100 line frames per second with an absolute guaranteed consistent and reliable rate.

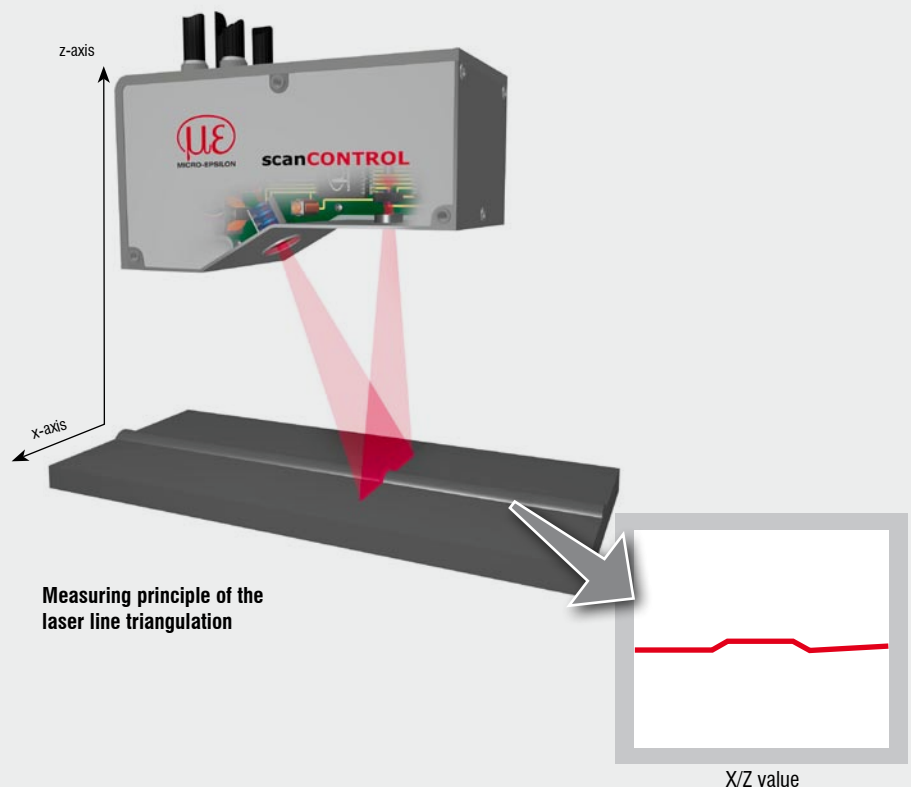

Measuring principle of the laser line triangulation

X/Z value

Interfaces for the individual software solution

scanCONTROL provides ideal conditions for realising your own software and system solutions. The sensor provides up to 64,000 calibrated measuring points/sec. in real-time via FireWire without requiring any additional hardware. The software development environment (SDK) included with the delivery together with the function library (LLT.dll) provides the basis of the communication which allows maximum flexibility and best performance via direct integration with many common programming languages (e.g. C/C++). The synchronous operation of several sensors is possible due to the high bandwidth of the FireWire bus.

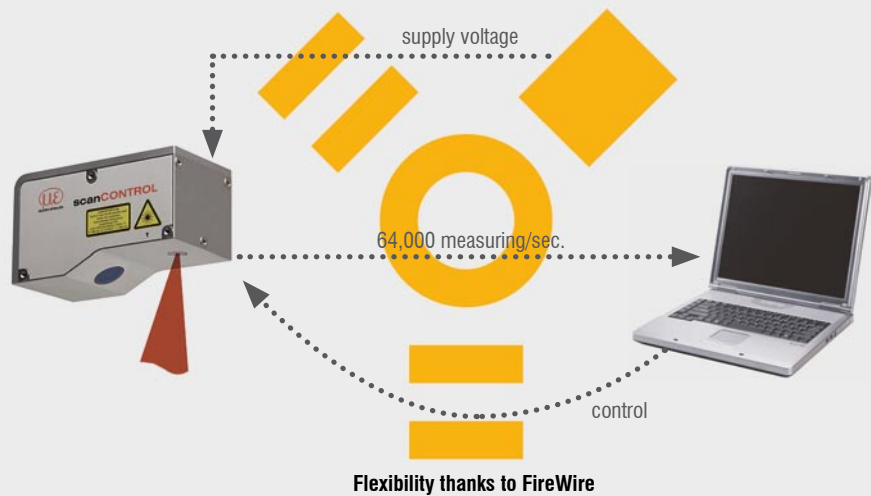

Resolution

The resolution is a key performance specification for any sensor. In case of a single point triangulation sensor this value is related to the height reading of one single measurement point of a target. It defines the smallest possible change in height at one location which can be detected by the sensor. For the laser line triangulation sensor the resolution specification is more complex. Usually not one single point is evaluated but a measurement is interpreted or derived from multiple points or an image respectively. There is a clear difference between the point resolution which determines the reproducibility of individual points and the resolution achieved for the individual measurement application, which uses image analysis and data processing to determine a desired value. For example, in case of a height measurement, a reference line can be fitted through several points, where the distance of this line measured shows a much higher resolution compared to the height reading of an individual point. For the laser line triangulation sensor this specification is referred to as "reference resolution".

Multiple scanner applications

scanCONTROL 2700 allows you to operate multiple systems at the same time. Due to the compact design, the easy wiring and the economic cost, building a system, where several sensors are required to be cascaded, is an easy task and opens new opportunities for more complex applications.

The scanCONTROL concept

The basic software package included in the delivery makes it possible to record, store and visualise online or offline as well as exporting an MS-Excel compatible format by using ICONNECT and 3D-View. In addition, scanCONTROL 3D-Data offers even more options for the data export in order to process the data further with any imaging analysis software. The free SDK software development kit offers maximum programming flexibility for almost any programming platform. Having direct access to all the possible features and settings of this sensor the possibilities for new applications, where conventional sensors fail, are endless. The version scanCONTROL 2X10 offers a plug & play solution for standard measurement tasks. Profile analysis threads are downloaded directly into the controller where the images are processed and the sensor outputs ready to go sensor data such as: step, angle, height, bead, width, gap.

The modular scansYSTEM that also includes a system unit is used when measured values are logged, calculated, analysed and made available via the Ethernet. In addition, scansYSTEM provides the option to calculate the profile data of several sensors. Comprehensive software tools are available for more complex 2D/3D measuring tasks. The determination, calculation and evaluation of the measured values is then carried out using a system unit which is housed in a top hat rail casing suitable for industrial applications.

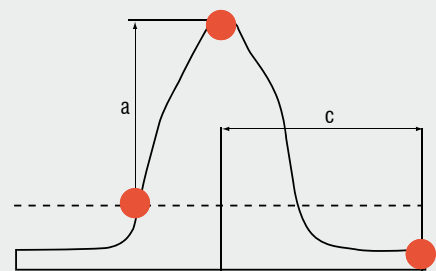

System unit for complex calculations of profile data: scanSYSTEM

Applications

The scanCONTROL 2700 allows the acquisition of line profile data, 3D image as well as the intensity image in real time. Unique absolute calibrated profile data (x, z) guarantee true and accurate measurement for many applications where conventional vision sensors fails.

Regardless of the position, angle and ambient conditions, the profiles are output as absolute calibrated data sets in a two – dimensional coordinate system which is fixed in respect to the sensor. This unique capability and compact design allows the sensor to be successfully used in dynamic, robotic and online applications without compromising accuracy. By moving the object or the sensor, it is possible to obtain a precise three dimensional image of your target as well as an intensity image.

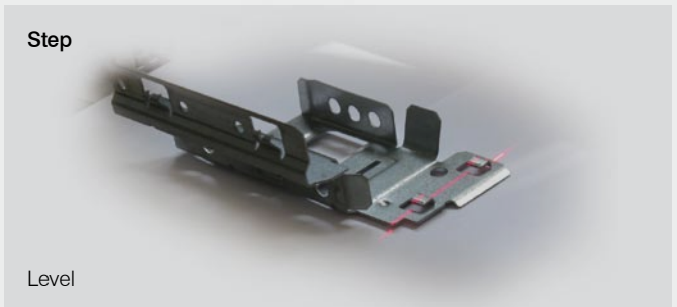
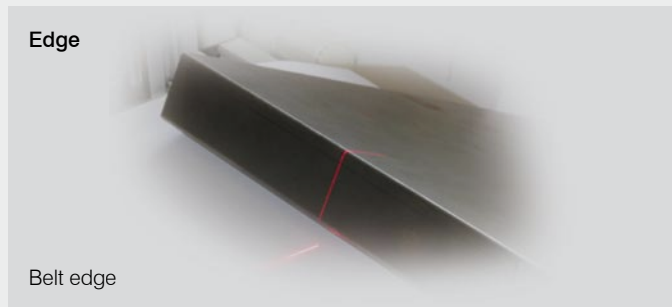
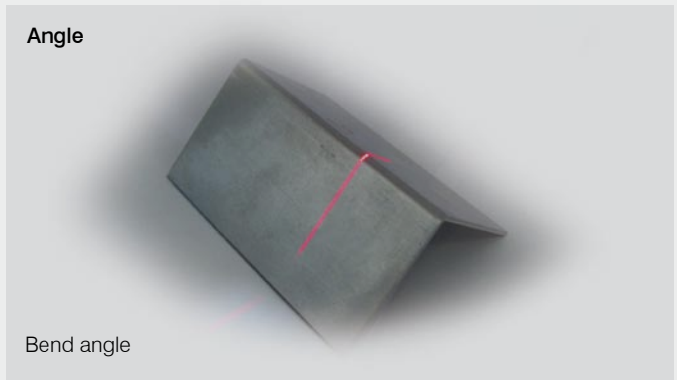

Weld seam detection Glue inspection Profile monitoring	Groove width and depth Robot guidance Positioning	Gap detection	Edge detection	Edge measurement Edge counting	Angle measurement Parallel measurement
Circle measurement Roundness measurement	Welding pearls inspection	Surface detection Planarity measurement	Peak measurement Peak counting	Thickness measurement	Width measurement

Profile

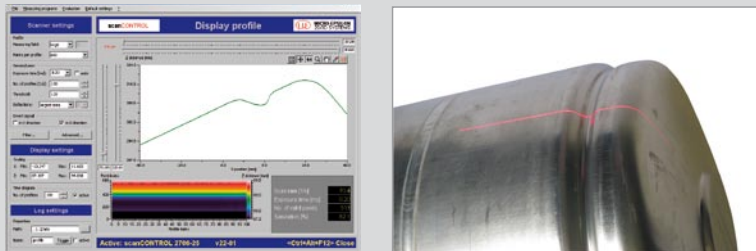

Recording the profile with scanCONTROL demo software

A profile consists of maximum 640 measurement points representing calibrated values for X, Z and intensity. These points are taken simultaneously across the entire line and made immediately available for the real time evaluation of the profile. The demo software included in the scope of delivery allows to tune, display, store, load and export the profiles in a MS-Excel compatible format.

Model		scanCONTROL 2700-25	scanCONTROL 2700-100
Measuring range x-axis	standard measuring range	25mm	100mm
Start of measuring range		90mm	350mm
End of measuring range		115mm	450mm
Start of extended measuring range	approx.	85mm	300mm
End of extended measuring range	approx.	125mm	600mm
Linearity		±0.2% FSO (3σ)	
Resolution	x-axis	640 points/profile	
	reference resolution	4μm	15μm
Profile frequency		100Hz (standard measuring field)	
Light source		semiconductor laser approx. 658nm, 20° aperture angle standard 2M: 10mW, E≤55W/m²; optional 3B: 20mW reduced 10mW	
Cable length		up to 10m without hubs and full data rate, up to 50m with hubs and/or restrictions	
Protection class		IP 64	
Operating temperature		0°C to 50°C	
Storage temperature		-20°C to 70°C	
Output/Input		1x firewire, laser off (optional), 1x RS422 programmable (interface or synchronisation or encoder input)	
Display		1x laser, 1x power/error/status	
Supply		8-30VDC, 500mA	
Electromagnetic compatibility (EMC)		CE EN 50081-2-living quarters EN 50082-2-industrial sector	
Galvanic isolation		Only at RS422, no isolation of 24V-supply, internal circuit and FireWire bus. If isolation necessary, external 24V-DC-DC-converter required	
Weight		appr. 700g	appr. 850g

FSO = Full scale output

SMR = Start Measuring Range, MR = Midrange, EMR = End of Measuring Range

*according to a singular averaging across the measuring field (640 points)

Measuring object: Micro-Epsilon standard object (metallic, diffusely reflecting material)



The scanCONTROL 2700 laser unit operates with a semiconductor laser featuring a wavelength of approx. 658nm (visible/red) and a 10mW optical output (laser class 2M)

scanCONTROL 2700-25

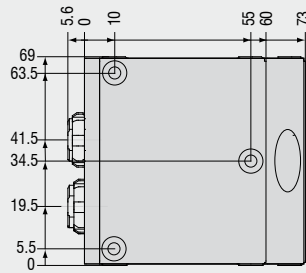
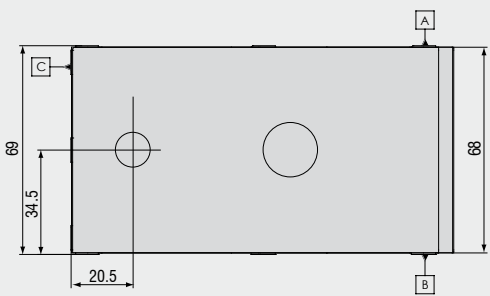
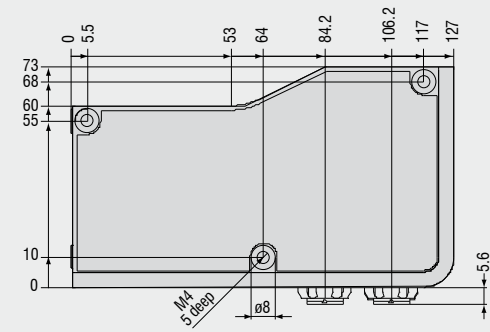

Three mounting bores M4x5 on each layer A, B, C

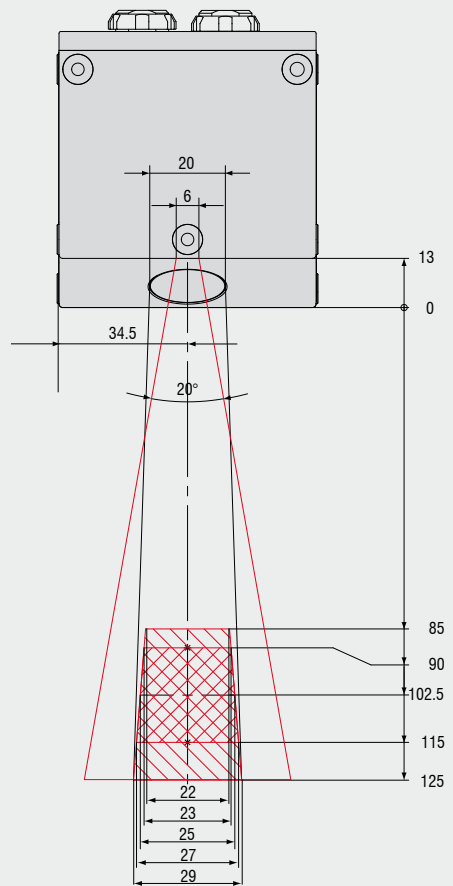
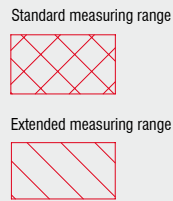
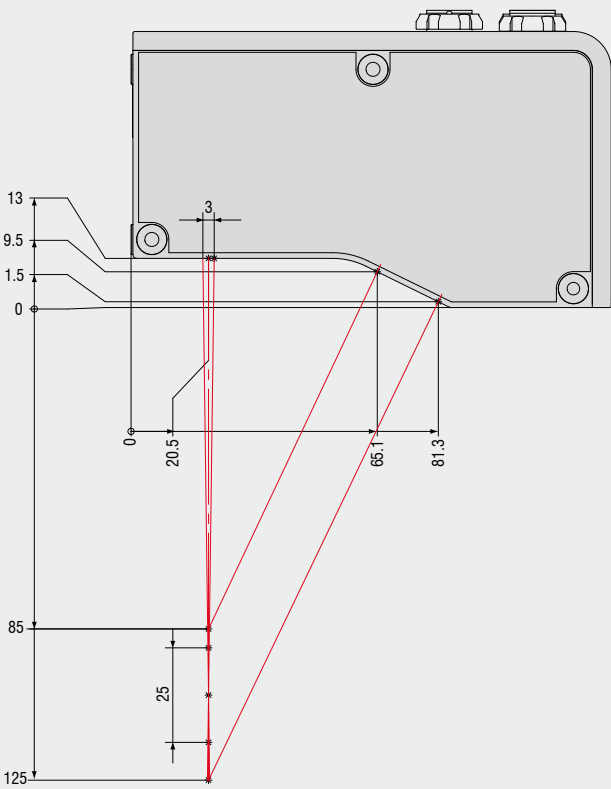

scanCONTROL 2700-100

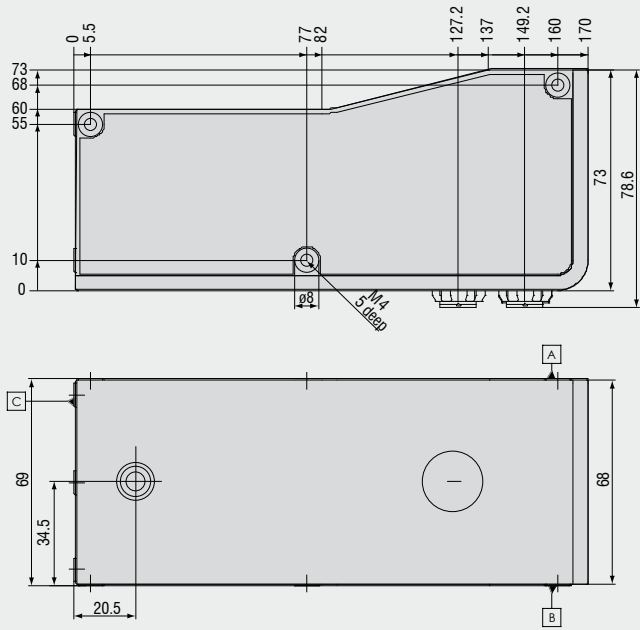

Three mounting bores M4x5 on each layer A, B, C

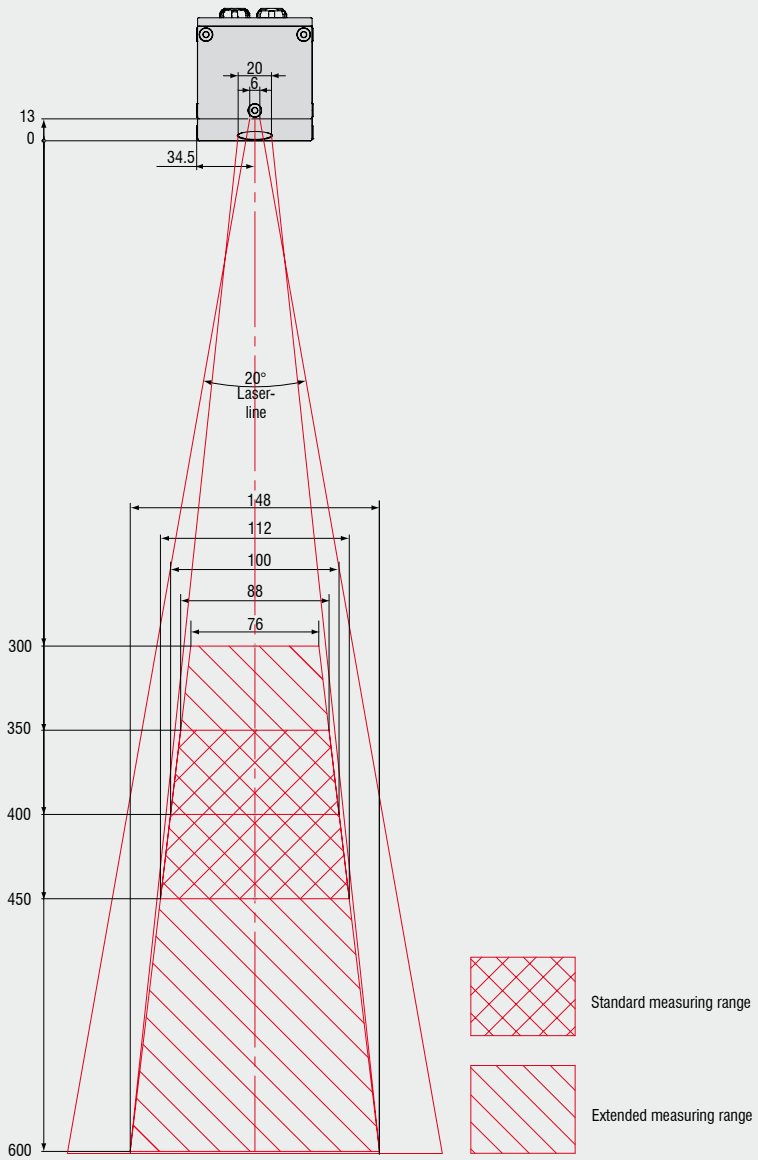
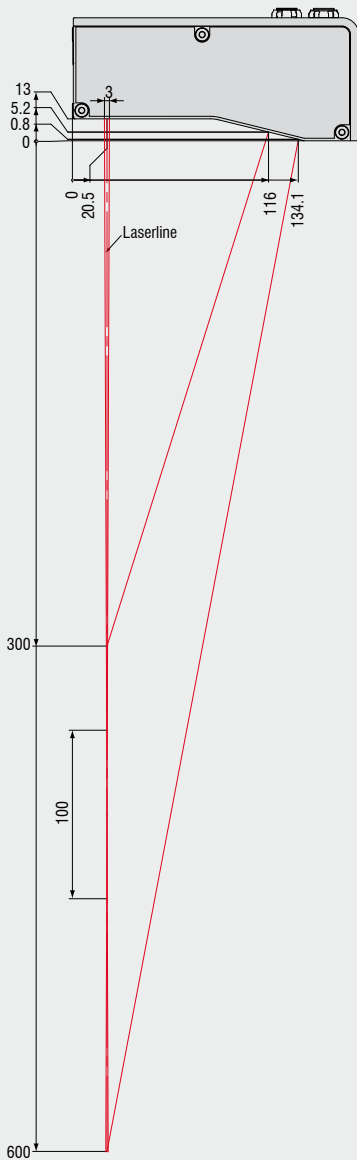

Standard scope of delivery scanCONTROL 2700

- scanCONTROL 2700
- Interface cable and supply cable (4.5 m)
- scanCONTROL demo software
- scanCONTROL 3D-View software
- Development environment for integrating the sensor into C/C++ programs

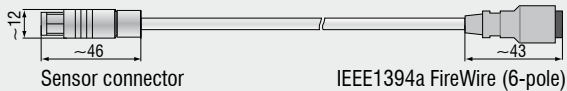
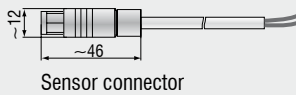
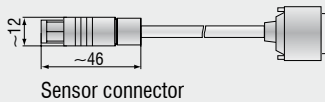
Connecting cable for power supply and interfaces**FireWire interface cable with integral power supply****External power supply cable****RS422 Interface cable****High performance sensors made by Micro-Epsilon****Sensors and systems for displacement, position and dimension**

- Eddy current sensors
- Optical and laser sensors
- Capacitive sensors
- Inductive sensors
- Draw-wire sensors
- Optical micrometers
- 2D/3D profile sensors
- Image processing

**Sensors and measurement devices for non-contact temperature sensors**

- Online instruments
- Handheld devices

**Measuring systems for quality control**

- for plastic and film
- for tire and rubber
- for web material
- for automotive components
- for glass