

EDS-P510 Series

7+3G-port Gigabit PoE managed Ethernet switches



The certification logos shown here apply to some or all of the products in this section. For details, see "Regulatory Approvals" under "Specifications" below.

- > 4 IEEE 802.3af-compliant PoE and Ethernet combo ports
- > Provides up to 15.4 watts at 48 VDC per PoE port
- > Intelligent power consumption detection, classification, and PoE scheduling function
- > 3 combo (10/100/1000BaseT(X) or 100/1000BaseSFP slot) Gigabit ports; 2 ports for redundant ring and 1 port for uplink
- > Turbo Ring (recovery time < 20 ms), RSTP/STP (IEEE 802.1w/D) for Ethernet redundancy
- > QoS, IGMP snooping/GMRP, VLAN, LACP, SNMPv1/v2c/v3, RMON, IEEE 802.1X, HTTPS, and SSH supported



Introduction

The EDS-P510 series includes Gigabit managed redundant Ethernet switches that come standard with 4 10/100BaseT(X) 802.3af (PoE) compliant Ethernet ports and 3 combo Gigabit Ethernet ports. The EDS-P510 switches provide up to 15.4 watts of power per PoE port, and allow power to be supplied to connected devices (such as surveillance cameras, wireless access points, and IP phones) when AC power is not readily available or is cost-prohibitive to provide locally. The EDS-P510 switches are highly versatile, and their SFP fiber port

can transmit data up to 80 km from the device to the control center with high EMI immunity. The Ethernet switches support a variety of management functions, including Turbo Ring, RSTP/STP, IGMP, VLAN, QoS, RMON, bandwidth management, and port mirroring. The EDS-P510 series is designed especially for security automation applications such as IP surveillance, and gate of entry systems, which can benefit from a scalable backbone construction and Power-over-Ethernet support.

Features and Benefits

- Advanced PoE management function
- IPv6 Ready logo awarded (IPv6 Logo Committee certified)
- IEEE 1588 PTP (Precision Time Protocol) for precise time synchronization of networks
- DHCP Option 82 for IP address assignment with different policies
- Modbus/TCP industrial Ethernet protocol supported
- IEC 61850 GOOSE messaging compliance
- Turbo Ring (recovery time < 20 ms at full load) and RSTP/STP (IEEE 802.1w/D)
- IGMP snooping and GMRP for filtering multicast traffic
- Port-based VLAN, IEEE 802.1Q VLAN, and GVRP to ease network planning
- QoS (IEEE 802.1p/1Q) and TOS/DiffServ to increase determinism
- Port Trunking for optimum bandwidth utilization
- IEEE 802.1X, HTTPS, and SSH to enhance network security
- SNMPv1/v2c/v3 for different levels of network management
- RMON for efficient network monitoring and proactive capability
- Bandwidth management to prevent unpredictable network status
- Lock port function for blocking unauthorized access based on MAC address
- Port mirroring for online debugging
- Automatic warning by exception through e-mail, relay output

Specifications

Technology

Standards:

IEEE 802.3af for Power-over-Ethernet
 IEEE 802.3 for 10BaseT
 IEEE 802.3u for 100BaseT(X) and 100Base FX
 IEEE 802.3ab for 1000BaseT(X)
 IEEE 802.3z for 1000BaseSX/LX/LHX/ZX
 IEEE 802.3x for Flow Control
 IEEE 802.1D for Spanning Tree Protocol
 IEEE 802.1w for Rapid STP
 IEEE 802.1Q for VLAN Tagging
 IEEE 802.1p for Class of Service
 IEEE 802.1X for Authentication
 IEEE 802.3ad for Port Trunk with LACP

Protocols: IGMPv1/v2 device, GMRP, GVRP, SNMPv1/v2c/v3, DHCP Server/Client, DHCP Option 66/67/82, BootP, TFTP, SNMP, SMTP, RARP, RMON, HTTP, HTTPS, Telnet, SSH, Syslog, Modbus/TCP (Available Soon: SNMP Inform, LLDP, IEEE 1588 PTP, IPv6)

MIB: MIB-II, Ethernet-Like MIB, P-BRIDGE MIB, Q-BRIDGE MIB, Bridge MIB, RSTP MIB, RMON MIB Group 1, 2, 3, 9

Flow Control: IEEE 802.3x flow control, back pressure flow control

Switch Properties

Priority Queues: 4

Max. Number of Available VLANs: 64

VLAN ID Range: VID 1 to 4094

IGMP Groups: 256

Interface

Fiber Ports: 100/1000BaseSFP slot

RJ45 Ports: 10/100BaseT(X) or 10/100/1000BaseT(X) auto negotiation speed

Console Port: RS-232 (RJ45 connector)

DIP Switches: Turbo Ring, Master, Coupler, Reserve

LED Indicators: PWR1, PWR2, FAULT, 10/100/1000, 10/100, MASTER, COUPLER, PoE

SFP-1G Series

1G-port Gigabit Ethernet SFP modules



- > Compliant with IEEE 802.3z
- > Differential LVPECL inputs and outputs
- > Single 3.3 V power supply
- > TTL signal detect indicator
- > Hot pluggable
- > Class 1 laser product, complies with EN60825-1

The certification logos shown here apply to some or all of the products in this section. For details, see "Regulatory Approvals" under "Specifications" below.



Specifications

Interface

Ethernet Ports: 1

Connectors: Duplex LC Connector or Simplex LC Connector (WDM-type only)

Note: WDM-type SFP modules must be used in pairs (e.g., SFP-1GXXALC and SFP-1GXXBLC)

Optical Fiber

	Gigabit Ethernet												
	SFP-SX	SFP-LSX	SFP-LX	SFP-LH	SFP-LHX	SFP-ZX	SFP-EZX	SFP-10A	SFP-10B	SFP-20A	SFP-20B	SFP-40A	SFP-40B
Wave-length	850 nm	1310 nm	1310 nm	1310 nm	1310 nm	1550 nm	1550 nm	TX 1310 nm, RX 1550 nm	TX 1550 nm, RX 1310 nm	TX 1310 nm, RX 1550 nm	TX 1550 nm, RX 1310 nm	TX 1310 nm, RX 1550 nm	TX 1550 nm, RX 1310 nm
Max. TX	-4 dBm	-1 dBm	-3 dBm	-2 dBm	1 dBm	5 dBm	5 dBm	-3 dBm		-2 dBm		2 dBm	
Min. TX	-9.5 dBm	-9 dBm	-9.5 dBm	-8 dBm	-4 dBm	0 dBm	0 dBm	-9 dBm		-8 dBm		-3 dBm	
RX Sensitivity	-18 dBm	-19 dBm	-20 dBm	-23 dBm	-24 dBm	-24 dBm	-30 dBm	-21 dBm		-23 dBm		-23 dBm	
Link Budget	8.5 dB	10 dB	10.5 dB	15 dB	20 dB	24 dB	30 dB	12 dB		15 dB		20 dB	
Typical Distance	550 m ^a	2 km ^b	10 km ^c	30 km ^c	40 km ^c	80 km ^c	110 km ^c	10 km ^c		20 km ^c		40 km ^c	
Saturation	0 dBm	-3 dBm	-3 dBm	-3 dBm	-3 dBm	-3 dBm	-3 dBm	-1 dBm		-1 dBm		-1 dBm	

a. 50/125 μm, 400 MHz * km or 62.5/125 μm, 500 MHz * km @ 850 nm multi-mode fiber optic cable

b. 62.5/125 μm, 750 MHz * km @ 1310 nm multi-mode fiber optic cable

c. 9/125 μm single-mode fiber optic cable

Environmental Limits

Operating Temperature:

Standard Models: 0 to 60°C (32 to 140°F)

Wide Operating Temp. Models: -40 to 85°C (-40 to 185°F)

Storage Temperature: -40 to 85°C (-40 to 185°F)

Ambient Relative Humidity: 5 to 95% (non-condensing)

Regulatory Approvals

Safety: UL, TÜV

Warranty

Warranty Period: 3 years

Details: See www.moxa.com/warranty

Dimensions (unit = mm)

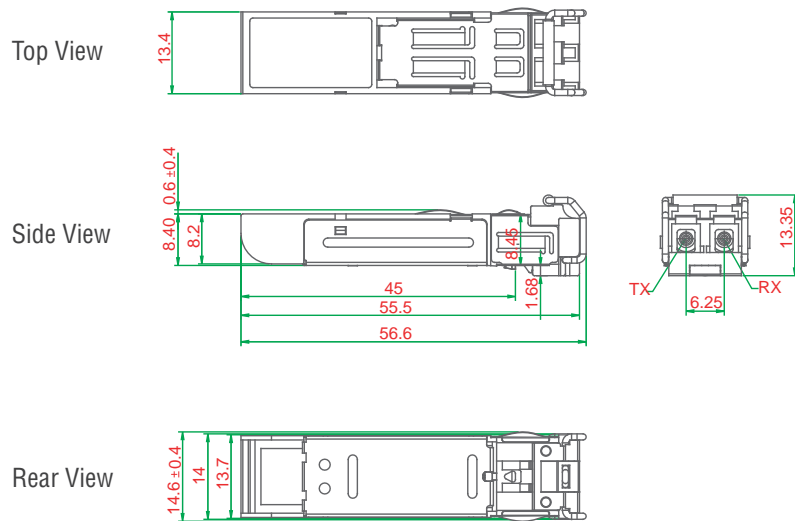

Ordering Information

SFP Modules

Available Models		Port Interface						
Standard Temperature (0 to 60°C)	Wide Temperature (-40 to 85°C)	1000BaseSX, LC Connector, 0.5 km	1000BaseLSX, LC Connector, 2 km	1000BaseLX, LC Connector, 10 km	1000BaseLH, LC Connector, 30 km	1000BaseLHX, LC Connector, 40 km	1000BaseZX, LC Connector, 80 km	1000BaseZX, LC Connector, 110 km
SFP-1GSXLC	SFP-1GSXLC-T*	1	---	---	---	---	---	---
SFP-1GLSXLC	SFP-1GLSXLC-T	---	1	---	---	---	---	---
SFP-1GLXLC	SFP-1GLXLC-T	---	---	1	---	---	---	---
SFP-1GLHLC	SFP-1GLHLC-T	---	---	---	1	---	---	---
SFP-1GLHXL	SFP-1GLHXL-T	---	---	---	---	1	---	---
SFP-1GZXLC	SFP-1GZXLC-T	---	---	---	---	---	1	---
SFP-1GEZXL	---	---	---	---	---	---	---	1

Note: SFP-1GSXLC-T: -20 to 75°C operating temperature

WDM-type (BiDi) SFP Modules

Available Models		Port Interface					
Standard Temperature (0 to 60°C)	Wide Temperature (-40 to 85°C)	1000BaseSFP, LC Connector, 10 km		1000BaseSFP, LC Connector, 20 km		1000BaseSFP, LC Connector, 40 km	
		TX 1310 nm, RX 1550 nm	TX 1550 nm, RX 1310 nm	TX 1310 nm, RX 1550 nm	TX 1550 nm, RX 1310 nm	TX 1310 nm, RX 1550 nm	TX 1550 nm, RX 1310 nm
SFP-1G10ALC	SFP-1G10ALC-T	1	---	---	---	---	---
SFP-1G10BLC	SFP-1G10BLC-T	---	1	---	---	---	---
SFP-1G20ALC	SFP-1G20ALC-T	---	---	1	---	---	---
SFP-1G20BLC	SFP-1G20BLC-T	---	---	---	1	---	---
SFP-1G40ALC	SFP-1G40ALC-T	---	---	---	---	1	---
SFP-1G40BLC	SFP-1G40BLC-T	---	---	---	---	---	1

The SFP-1G series modules can be used with the following products

- EDS-728/828 series: IM-2GSFP series Gigabit Ethernet interface modules
- EDS-G509 series: 9G-port full Gigabit managed Ethernet switches
- EDS-518A series: 16+2G-port Gigabit managed Ethernet switches
- EDS-510A series: 7+3G-port Gigabit managed Ethernet switches
- EDS-P510 series: 7+3G-port Gigabit PoE managed Ethernet switches
- PT and IKS series: PM-7200-2G/4G series Gigabit Ethernet interface modules
- EDS-G308 series: 8G-port full Gigabit unmanaged Ethernet switches
- IMC-101G series: Industrial Gigabit media converters

SFP-1FE Series

1-port fast Ethernet SFP modules



- > Single + 3.3 V power Supply
- > Small Form Factor Pluggable MSA Compliant
- > PECL Differential Inputs and Output
- > TTL Signal Detect Indicator
- > Compliant with SONET / SDH Standard
- > LC Duplex Connector
- > EEPROM with serial ID functionality
- > Class 1 Laser International Safety Standard IEC 825 Compliant

The certification logos shown here apply to some or all of the products in this section. For details, see "Regulatory Approvals" under "Specifications" below.



Specifications

Interface

Ethernet Ports: 1

Connectors: Duplex LC Connector

Optical Fiber

	Fast Ethernet		
	SFP-M	SFP-S	SFP-L
Wavelength	1300 nm	1310 nm	1550 nm
Max. TX	-18 dBm	0 dBm	0 dBm
Min. TX	-8 dBm	-5 dBm	-5 dBm
RX Sensitivity	-34 dBm	-34 dBm	-34 dBm
Link Budget	26 dB	29 dB	29 dB
Typical Distance	4 km ^a	40 km ^b	80 km ^b
Saturation	0 dBm	-3 dBm	-3 dBm

a. 50/125 μm or 62.5/125 μm, 800 MHz * km @ 1300 nm multi-mode fiber optic cable

b. 9/125 μm single-mode fiber optic cable

Environmental Limits

Operating Temperature: -40 to 85°C (-40 to 185°F)

Storage Temperature: -40 to 85°C (-40 to 185°F)

Ambient Relative Humidity: 5 to 95% (non-condensing)

Regulatory Approvals

Safety: UL, TÜV

Warranty

Warranty Period: 3 years

Details: See www.moxa.com/warranty

Dimensions (unit = mm)

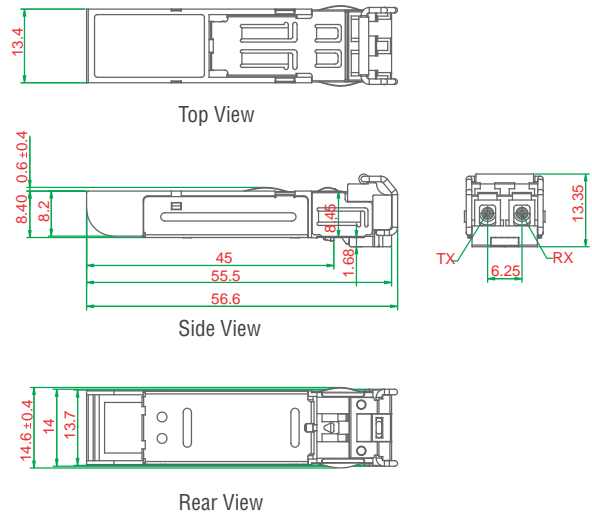

Ordering Information

Available Models	Port Interface			
	Wide Temperature (-40 to 85°C)	100BaseFX, Multi-mode, LC Connector, 4 km	100BaseFX, Single-mode, LC Connector, 40 km	100BaseFX, Single-mode, LC Connector, 80 km
SFP-1FEMLC-T		1	---	---
SFP-1FESLC-T		---	1	---
SFP-1FELLC-T		---	---	1

The SFP-1FE series modules can be used with the following products

EDS-G509 series: 9G-port full Gigabit managed Ethernet switches

EDS-G308 series: 8G-port full Gigabit unmanaged Ethernet switches

EDS-P510 series: 7+3G-port Gigabit PoE managed Ethernet switches