



Smalley®

Steel Ring Company

SPIROLOX RETAINING RINGS



CONSTANT SECTION RINGS



SMALLEY WAVE SPRINGS

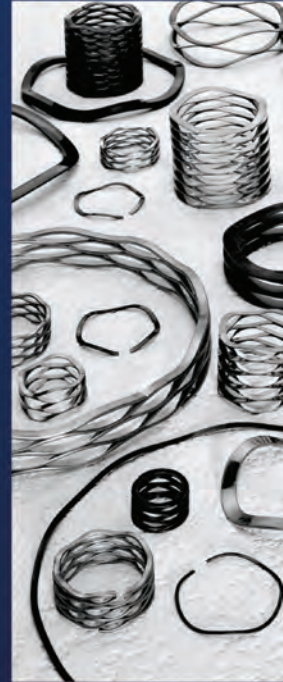

STOCK SIZES

Over 10,000 Standards
Carbon & Stainless Steel

SPECIAL DESIGNS

.200" - 120" / 5mm - 3,000mm
No - Tooling - Charges

Engineering &
Parts Catalog

www.smalley.com

847.719.5900

info@smalley.com

Smalley Wave Springs

All Springs Are Not Equal®

free samples • free CAD models

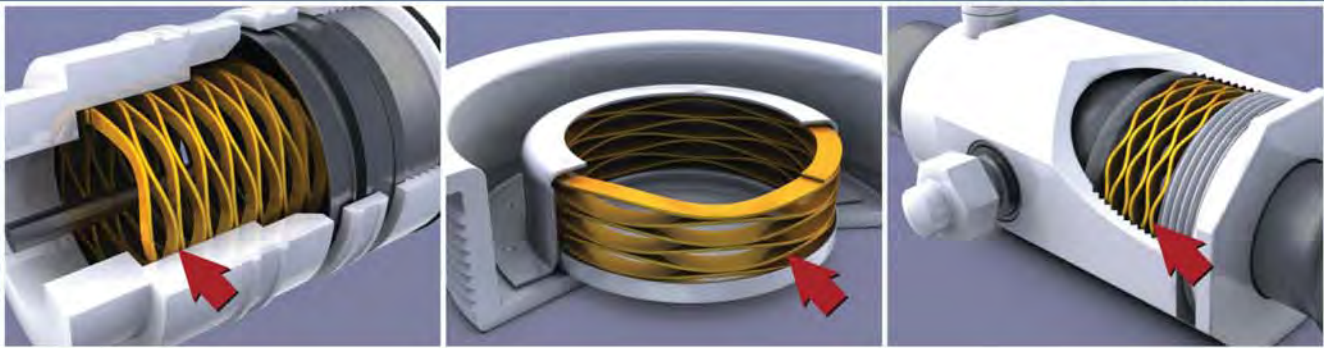

SAVE SPACE

- Reduce spring heights by up to 50% compared to coil springs
- Same force and deflection as coil springs
- Fits in tight radial and axial spaces

STAINLESS STEEL FROM STOCK

- 4,000 stock sizes in carbon and stainless steel
- Available from 1/4" to 16" diameters from stock
- No-Tooling-Costs™ on specials; available from .200" to 120"



SMALLEY WAVE SPRING



COIL SPRING

www.smalley.com



Smalley®
Steel Ring Company

www.smalley.com/getcatalog • info@smalley.com
Lake Zurich, IL • 847.719.5900 • Fax: 847.719.5999



About Smalley

Smalley Steel Ring Company	4
----------------------------	---

About Wave Springs

General Spring Information/Comparator	12
Spring Applications	15

Wave Springs

From Stock	Series	Spring Type	
	SSR	Gap/Overlap Single Turn	18
	SSR-N	Narrow Single Turn	20
	RW	Wavo (Round Wire) Single Turn	21
	SSB	Metric Bearing Pre-Load Single Turn	22
		Metric Bearing Cross Reference Chart	24
	C/CS	Crest-to-Crest/Shim Ends	26
	CM/CMS	Metric Crest-to-Crest	33
	SSRS	Shim	40
		Spring Tester/Fatigue Tester	41

About Retaining Rings

General Ring Information	42
Ring Selection Guide/Ring Interchange Listing	44
Ring Applications	47
Assembly/Removal Methods	50

Internal Retaining Rings

From Stock	Series	Rating, Ring Type	
	VH	Light Duty Single Turn, Spirolox	52
	WH	Medium Duty 2-Turn, Spirolox	54
	WHW	WaveRing, Spirolox	57
	WHT	Medium Heavy Duty 2-Turn, Spirolox	58
	WHM	Heavy Duty 2-Turn, Spirolox	60
	FHE	Heavy Duty Single Turn, Constant Section	62
	VHM	Metric Light Duty Single Turn, Spirolox	64
	EH	Metric Aerospace, Spirolox	66
	DNH	Metric DIN, Spirolox	68
	FH	Metric DIN, Constant Section	70
	HH	Hoopster	72
	XAH	Constant Section	73
	XDH	Constant Section	75

External Retaining Rings

From Stock	Series	Rating, Ring Type	
	VS	Light Duty Single Turn, Spirolox	76
	WS	Medium Duty 2-Turn, Spirolox	78
	WSW	WaveRing, Spirolox	81
	WST	Medium Heavy Duty 2-Turn, Spirolox	82
	WSM	Heavy Duty 2-Turn, Spirolox	84
	FSE	Heavy Duty Single Turn, Constant Section	86
	VSM	Metric Light Duty Single Turn, Spirolox	88
	ES	Metric Aerospace, Spirolox	90
	DNS	Metric DIN, Spirolox	92
	FS	Metric DIN, Constant Section	94
	HS	Hoopster	96
	XAS	Constant Section	97
	XDS	Constant Section	99

Laminar Seal Rings

Laminar Seal Rings	100
Engineering	
Special Designs	102
Introduction to Smalley Engineering	103
Materials / Finishes	104
Spring Design	109
Ring Design	114
End Configurations	120
Hoopster Design	121
Smalley Website	122
Spring Checklist	124
Ring Checklist	125
How to Order	126
Glossary	128
Sample Request Form	130

Copyright 2011 by
Smalley Steel Ring Company
Lake Zurich, IL 60047
All rights reserved

The following are trademarks of Smalley Steel Ring Company: Gap-Type, No-Tooling-Costs, No-Tooling-Charges, Overlap-Type.

The following are registered trademarks of Smalley Steel Ring Company: All Springs Are Not Equal, Circular-Grain, Crest-to-Crest, Edgewound-Coiled, No Ears to Interfere, Quick Ship, Smalley, Spirawave, Spirolox, WaveRing, Wavo, Hoopster.



Company Profile

Founded in 1918 as a supplier of precision automotive piston rings, Smalley Steel Ring Company had many years of successful growth in an expanding marketplace. Having had a variety of products throughout the years, it wasn't until 1963, when present ownership began the development of products in the wire forming industry. Spiral Retaining Rings and Wave Springs emerged and Smalley developed into a reputable manufacturer of precision rings, springs & wire forms. But one thing never changed from years back, and that is our commitment to providing ever-higher levels of quality, performance, deliverability, and value to our customers. Today, Smalley Steel Ring Company is a market leader in the industrial retaining ring and wave/compression spring business; a position we work hard to maintain and build upon.

Every Smalley ring and spring is engineered and manufactured to the highest quality standards using skills and processes we have honed over three quarters of a century. Our obsession with quality, combined with our near-perfect record of on-time delivery, has earned us an approved supplier status with leading OEM manufacturers around the world. Due to the ceaseless demands we place upon ourselves, Smalley has won the coveted title of Preferred Source in the most demanding applications: automotive, agriculture, aerospace, electronics, appliance, industrial, medical and power generation.

While we are understandably proud of the recognition we have received, ultimately, it is our products that set us apart. Unlike stamped rings and springs, which are die-stamped through the metal grain, our edgewound rings and springs have a circumferential metal grain structure that gives them exceptional strength, dimensional stability, and predictable performance characteristics.

Finally, every Smalley ring and spring is backed by our continued support. We are constantly searching ways to expand and improve our Customer Service and Engineering/Technical Assistance. We welcome your comments and your design challenges. Engineers are available to help assist with any design questions.

With regional offices in Europe, we are prepared to service our European customers. Smalley provides customized global supply chain solutions, to meet your WORLDWIDE manufacturing requirements, in Europe, Asia Pacific and the America's.

Please call us at **847.719.5900** or visit our website today!

**One thing has never changed...
and that is our commitment to
providing ever-higher levels of quality,
performance, deliverability, and value
to our customers.**

Products

All of Smalley's wave springs and retaining rings are manufactured with our unique edgewinding manufacturing process. This eliminates any tooling charges, greatly increases design flexibility and reduces lead times as dies do not have to be produced.



Retaining Rings

Unlike die-stamped circlips / retaining rings, Spirolox Retaining Rings and Constant Section Rings are coiled on edge to the exact diameter required. They have a uniform cross-section (or to use our terminology, No Ears To Interfere within an assembly) and are free of burrs. Spirolox Retaining Rings meet military and aerospace specifications and are found in thousands of mechanical products around the world.



Wave Springs

Wave springs are precise flat wire compression springs that fit into assemblies that other springs cannot. Since the overall lengths and operating heights of wave springs are lower than those of conventional round wire springs, they will often reduce the size of an assembly by as much as 50%. Of course, this will also reduce the part weight and raw material cost of every spring produced.

Raw Material

As we meet the increasing demand for more raw material sizes, the flat wire rolling mill operation in our plant continues to grow. Years ago, Smalley began a vertical integration that has evolved into the production of hundreds of material cross-sections in a wide variety of alloys.



Our goal... to supply Smalley customers with uncompromising quality and service.

Manufacturing

Edgewinding, also known as “The No-Tooling-Cost Process”, is our precision forming operation that coils pre-tempered flat wire on edge to create a near-perfect circle. (Visualize a Slinky®, the coiled metal toy which has delighted generations of children.) Circular-Grain metallurgy gives our products strength and stability far superior to that of conventional retaining rings and wave washers which are simply stamped through the metal grain. Smalley edgewound products can be coiled to your exact specification in any diameter and with any number of turns (layers or coils), effectively eliminating material waste.

As flexible as it is precise, our edgewinding process accommodates your design changes without the need for additional tooling and die modifications. This facilitates your developmental work, allowing us to produce your low-quantity custom orders and your working prototypes quickly and economically. Even after your initial prototype is produced, or in mid-stream production, our edgewinding process allows us to alter your design or dimensions with simple machine adjustments or a change in raw material size. After the revised specifications are approved, we complete and document the final setup. Then, we quickly resume production of your order, whether it consists of one part or one million.



Edgewinding Process

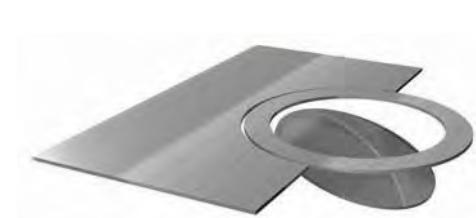

Conventional Stamping Process

Prototypes

About the easiest way to test a theoretical design is to produce a working prototype — a task at which Smalley excels. A prime example is the development of a custom wave spring. We can adjust dimensions, by changing the number of waves and the number of turns, and trying different combinations of spring variables. Finally, we test for function, before production, so we know we have it right.

Smalley-produced prototypes are also the most economical way to provide results on a trial-and-error basis. From one to a thousand pieces, we can produce, try, modify, and reproduce your design as often as necessary — all without special tooling costs.

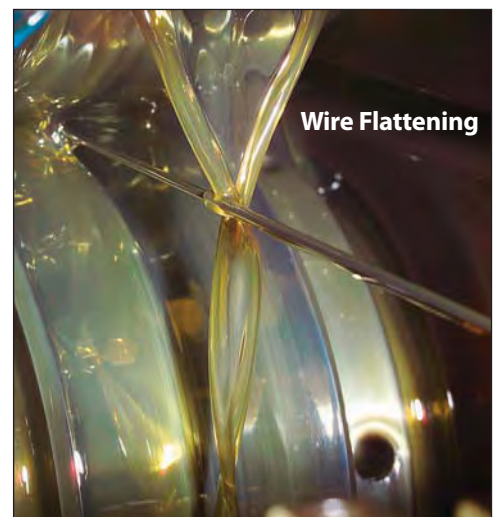

Finished Parts Warehouse

Smalley maintains a substantial parts inventory of every cataloged/standard retaining ring and wave spring — in both carbon and stainless steel. We do this to meet our JIT deliveries as well as any immediate requirement that you may have. In the rare circumstance that our inventory runs low, we can quickly replenish any item overnight.

In addition to our finished parts, we house a vast inventory of raw material sizes, stocked in thousands of pounds of flat wire. We are always ready to meet your needs for a quick turn-around in low to high quantities of existing or new designs.



Free

Need a Sample?

We offer free samples of any ring or spring found in our catalog.
See page 130.

Customer Service

Smalley is dedicated to giving you the most positive, efficient and economical service possible, each and every day. We continually train our staff on every important aspect of our business. We can split shipments to suit your "just-in-time" delivery requirements. We offer you lower prices for your annual higher-usage orders. Please contact us directly for complete details and ideas on how you can purchase economically.

General Sales Information

Description:

The product descriptions in this catalog are intended to provide the user with practical information for application selection. Since it is not possible to include complete detail on all parts, please contact Smalley for any information not included in the description which may be critical for a specific application.

Quotations:

We will provide written or verbal quotations as requested.

Returns:

Parts not stocked which must be specially manufactured are not returnable except by special arrangement and will be subject to cancellation charges. Stocked parts may be returned for credit at a standard restocking charge (subject to condition). All returns of stocked parts must be made within 30 days from date of receipt of material.

Delivery:

Parts carried in stock normally will be shipped within 48 hours after receipt of an order. Special parts are normally delivered in 3 weeks (if no special processes are required) or as previously arranged.

Certifications:

Standard Certificate of Conformance will be supplied at no charge. Material and other Certifications for plating, load, etc. will be furnished as quoted.

Transportation:

As specified by the customer. In the absence of instructions, the shipping method will be selected by us. Insurance will be provided only at the customer's request.

Terms:

1/10/NET 30 on open accounts. For consideration of an open account, customers are requested to supply banking information and at least 3 commercial credit references.

Go to www.smalley.com for Terms and Conditions, which apply.

F.O.B.:

Factory, Lake Zurich, Illinois, USA

Packaging:

Rings and springs 1 $\frac{5}{16}$ " in diameter and under are bulk packaged. Rings and springs 1 $\frac{3}{8}$ " and over in diameter are generally tube (coin) packaged in lengths 10 to 18 inches.



Smalley is the proud recipient of the
GM Supplier of the Year Award.

Engineering & Design Assistance

Smalley's engineering staff is always ready to address your application requirements. Usually, the sooner we are able to review what you need, the easier the solution will be. Please call us today.

We invite you to draw upon our resources. Over the years, Smalley engineers have built an extensive library of over 25,000 applications while designing rings and springs in mechanical components and assemblies. In addition, we offer computer-aided spring-design alternatives to meet your specifications.

There are many more options that we would be pleased to review with you once your design criteria are established. We are ready to help you with the selection of a standard part from our vast inventory, or to modify a standard part to meet your exact needs.

We are pleased to offer you additional step-by-step resources. The "Special Designs" section of this catalog will help you determine basic retaining ring and wave spring specifications. We also invite you to try the design section on our website for step-by-step interactive design guidelines and options. As you can see, we are well-equipped to help you develop the best design solution possible, just as we have for thousands of other companies in diverse industries.

Specials

At Smalley, specials are standard. It's easy to get a custom part from Smalley. With No-Tooling-Charges, die costs, or other fixture charges, we can manufacture a new ring or spring design in just two weeks or to meet your delivery schedules.

Fast, precise, and economically — that's how Smalley produces rings and springs, in short runs or high volumes. If you can't find a standard part to meet your needs from the wide selection in our catalog, please contact our engineering department for immediate assistance with your special design requirements. And please note: Smalley Rings and Springs are available from .200" to 120" in diameter.

CAD Downloads

Visit our website for CAD downloads in 90 different formats. It's easy to search and select a standard part for a quick upload to your computer.

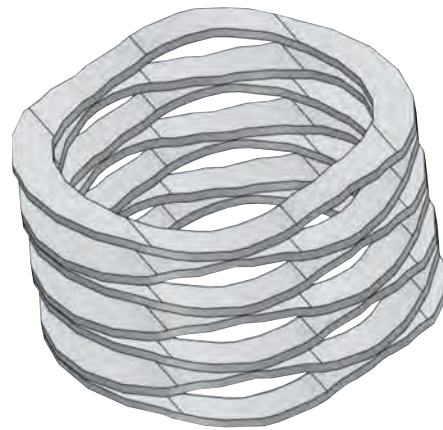

Quality Policy

Smalley has established, and is continuously improving upon, a program that is designed to meet the following objectives:

- **Total product conformance in terms of drawings, specifications and contractual requirements.**
- **100% on-time delivery performance.**
- **Superior products with exceptional value.**
- **Prompt, professional and courteous response in every facet of design, manufacturing, sales, and customer service.**
- **Continued development and use of the latest technology.**

Quality Assurance

Smalley's Total Quality Management philosophy dictates our commitment to quality and customer satisfaction. While this commitment has earned us official certification (ISO 9001, ISO/TS 16949, AS 9100 and ISO 14001), quality assurance and customer satisfaction mean much more at Smalley. They are tradition; the very foundation upon which we have built our company. From the beginning, we have never lost sight of our goal: "to supply Smalley customers with uncompromising quality and service."

Smalley is committed to a quality policy that requires conformance to specification with controlled lot variation about the target, statistical quality control, defect prevention, and annual improvement in process and product. This is a company-wide commitment involving every Smalley employee. Each person works towards excellence, individually and cooperatively, to provide superior products and services.

A history of quality and strict compliance with military and aerospace standards has earned Smalley an approved supplier status with many leading original equipment manufacturers worldwide. Smalley has worked diligently to become their Preferred Source for spiral retaining rings and wave springs.

In accordance with the requirements of ISO 9001, ISO/TS 16949, AS 9100 and ISO 14001, we have established and are continuously improving our quality systems. Use of the latest technology, including statistical tools, has helped us achieve and maintain the world-class quality associated with the Smalley name for more than 40 years.

Smalley uses statistical quality control tools to assure the capability and stability of our coiling process. To begin with, we identify common dimensions to monitor and special causes of variation in the product. Then, we collect and analyze data on these critical dimensions. We perform disciplined sampling and take measurements during in-line and final inspection, and yet again, during pre-shipping inspection.

We make formal SQC in-house training programs mandatory for many Smalley employees involved with manufacturing.



This training has noticeably developed quality awareness and responsibility at all levels. Our employees have a clear understanding of what is expected, a means of regulating their processes and checking their output, and statistical tools to determine when machine adjustments are required.

Smalley's machine capability studies help us identify sources of variation before they become a problem. We analyze the capabilities of all production machinery in primary and secondary operations, heat treating, and finishing. In addition, we follow our own meticulous procedures to determine the reproducibility and repeatability of our gauging systems.

Due to the careful documentation of our quality, many Smalley customers have found that they can reduce or even eliminate their incoming inspections of our product. Many of our accounts have also revised their policy of dual sourcing and confidently rely on Smalley as their single source of Spirolox Retaining Rings, wave springs, constant section rings, expanders and other wire forms.

Defect prevention, or near-zero defects, is a key goal at Smalley. We use the latest automated inspection techniques to monitor production. As a result, we are constantly studying the causes of variation, improving upon and developing processes with capability indexes (Cpk) exceeding 1.33.

Continuous improvement is an integral part of Smalley's quality plan. We require each of our departments to design and implement projects to improve their respective systems.

Wave Spring Introduction

All Springs Are Not Equal®

Smalley Wave Springs offer the unique advantage of space savings when used to replace coil springs. By reducing spring operating height, wave springs also produce a decrease in the spring cavity. With a smaller assembly size and less material used in the manufacturing process, a cost savings is realized.

Wave springs operate as load bearing devices. They take up play and compensate for dimensional variations within assemblies. A virtually unlimited range of forces can be produced whereby loads build either gradually or abruptly to reach a predetermined working height. This establishes a precise spring rate in which load is proportional to deflection.

Functional requirements are necessary for both dynamic and static spring applications. Special performance characteristics are individually built into each spring to satisfy a variety of precise operating conditions. Typically, a wave spring will occupy an extremely small area for the amount of work it performs. The use of this product is demanded, but not limited to tight axial and radial space constraints.

Product Performance

With their smooth, circular coiled sinusoidal wave form, and rolled round edges of pre-tempered raw material, Smalley's edgewound Wave Springs offer many advantages over die stamped products.

Loads and spring rates are more accurate, more predictable, and may be tolerated better than 50 percent tighter than stampings. The force of a Smalley Wave Spring will increase at a uniform rate throughout most of its available deflection.

By any criteria, Smalley Wave Springs offer their users higher dependability and better performance. Since they are produced from full hard, pre-tempered raw material, there is no risk of distorting the spring during a hardening heat treatment. By contrast, subsequent manufacturing procedures for stamped wavy washers can lead to problems such as fatigue cracking and inaccurate or inconsistent loading between springs. All told, the metallurgy, the mechanical properties and the uniform dimensional stability of the Smalley edgewound Wave Spring provide a component for precision quality applications.

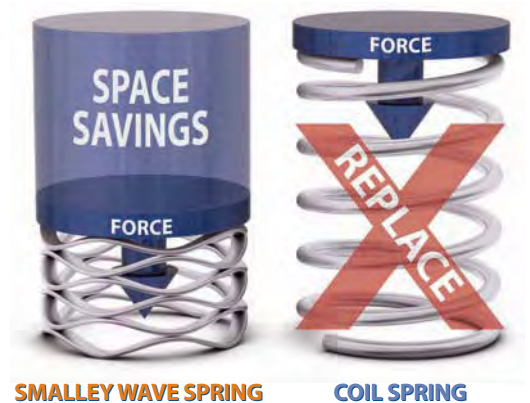

Wave Spring Types



Gap Type Wave Spring



Overlap Type Wave Spring

Gap & Overlap Type

Conventional Gap and Overlap Type Wave Springs are used in a wide variety of applications. For short deflections and low-medium forces, they function with precision and dependability.

These two types of Smalley Wave Springs permit radial expansion or growth in diameter within a cavity, without the binding or hang-up normally associated with die stamped wave washers. Just as their terms imply, the gap type is split to retain a gap between the ends, while the overlap type has overlapping ends. Thus, the ends are free to move circumferentially as the spring outside diameter grows during compression.

For example, the O.D. of a Gap Type Wave Spring would fit .020 loose per side in a bore. Its I.D. clears a shaft by .010 per side. As the spring is deflected, the O.D. and I.D. grow larger until the O.D. contacts the bore. Continued deflection causes the gap ends to move closer together while the O.D. presses against the bore. An Overlap Type Wave Spring permits this type of cycling action in a similar manner.

Crest-to-Crest[®]

Crest-to-Crest Wave Springs are prestacked in series, decreasing the spring rate proportionally to the number of turns. Uses are typically applications requiring low-medium spring rates and large deflections with low-medium forces. Among major advantages, this design eliminates the need to keep the wave crests aligned. The need to use a key locating device, or to insert a shim between individual springs is not necessary. Because the spring is integrally formed, the wave peaks hold their configuration.

As a replacement for helical compression springs, Crest-to-Crest springs can develop similar forces, yet occupy one-half (1/2) or less the axial space. This allows for strict space constraints. Crest-to-Crest Wave Springs will maintain the same force and load specifications of a conventional round wire spring, but with the advantages of resultant lowered and compacted operating heights, free heights, and solid heights.



continued 

Wave Spring Introduction

Wave Spring Types (cont'd)



Crest-to-Crest with Optional Shim Ends

Crest-to-Crest Wave Springs are also available with squared-shim ends. Shim ends provide a 360° contact surface when compared to the wave point contact of plain ends. The shim-ends, under load, more evenly distribute the spring's force upon adjacent components. This feature is similar to the concept of double-disc grinding springs for a flat surface. Shim ends have also been used to affix springs to mating components, as a flat locating surface that may be attached by various methods in the assembly.



Nested

Nested Wave Springs are pre-stacked in parallel from one continuous filament of flat wire. The need to stack individual springs for higher loads is no longer necessary. Nested springs result in a spring rate that increases proportionally to the number of turns. They can exert tremendous forces, yet maintain the precision of a circular-grain wave spring. In many applications, Nested Wave Springs replace Belleville Springs, particularly in cases where a high but accurate force is needed.



WAVO®

Wavo Springs are produced from round-section wire to provide higher loads while maintaining the accurate loading found in wave springs. As an alternative to Belleville Springs, the Wavo provides similar loads but with an accurate, predictable spring rate.



Linear Expanders

Linear expanders are a continuous wave formed (marcelled) wire length produce from spring tempered materials. They act as a load bearing device having approximately the same load/deflection characteristics as a wave spring.

Forces act axially or radially depending on the installed position. Axial pressure is obtained by laying the expander flat in a straight line. Circular wrapping the expander produces a radial force or outward pressure. Linear expanders are available cut to length or as a continuous coil, for the user to cut as needed.

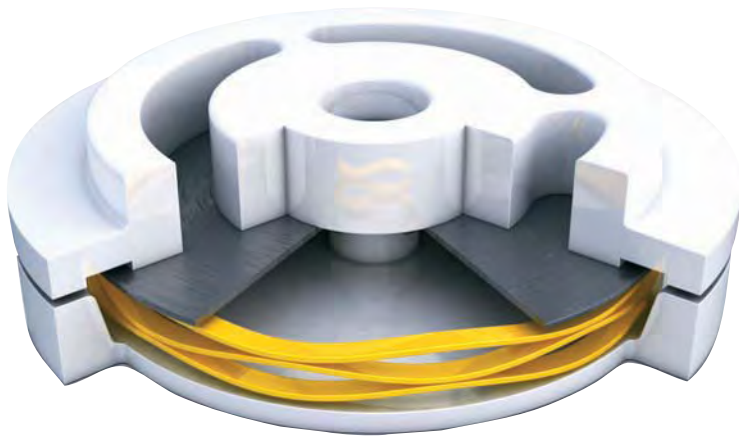

A. Pressure Relief Valve

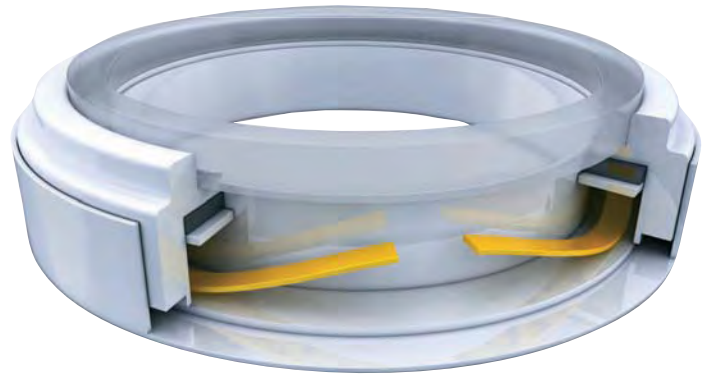

B. Face Seal

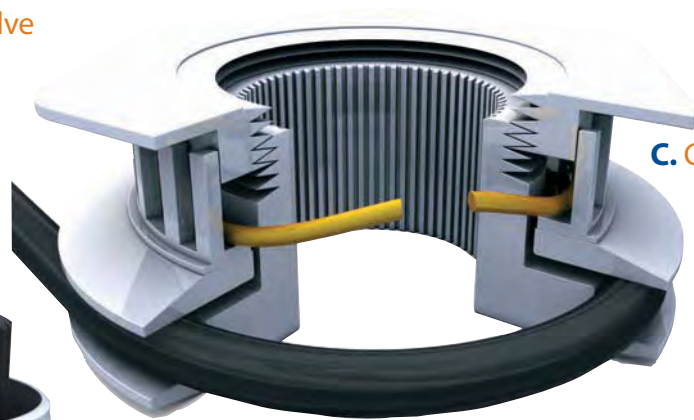

C. Clutch Drive



D. Bayonet Connector



E. Multi-Tooth Cutter

A. Pressure Relief Valve

An exact load applied to the top sealing plate was accomplished using a flat wire wave spring. Air pressure entering the top slots forces the plate away from the sealing surface providing the pressure relief mechanism.

B. Face Seal

Wave Spring applies pressure, to precisely load the carbon face against a mating surface, to properly seal fluids. The spring operates over a fixed working range and provides an exact force, unlike the stamped wavy washer it replaced which could not maintain the necessary spring rate.

C. Clutch Drive

Pressure on the round belt is produced by compressing the Wavo Spring through the sheave halves. The top threaded cap rotates to adjust the Wavo compression. The Wavo can produce a high force in a tight radial cavity.

D. Bayonet Connector

Overlap Type Wave Spring installed in an electronic connector assembly. As male and female components are rotated together into final assembly, the wave spring is compressed to its working height. In this position it exerts a constant force that locks both components together.

E. Multi-Tooth Cutter

A custom designed wave spring with locating tabs is contained in the housing. The spring applies a precise force to the two cutter halves, allowing them to oscillate but not rattle.

Wave Spring Applications

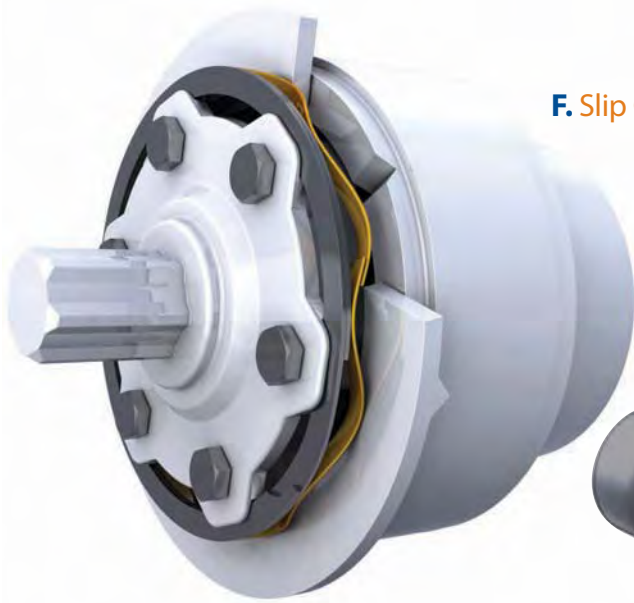

F. Slip Clutch

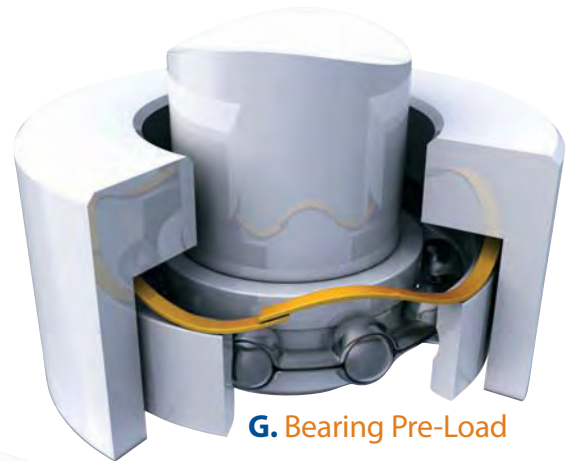

G. Bearing Pre-Load

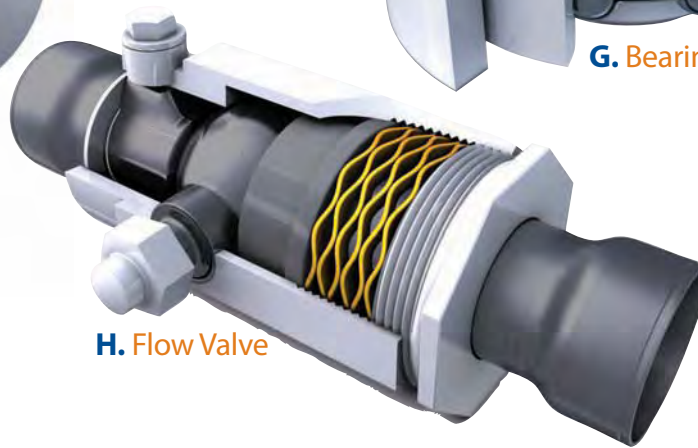

H. Flow Valve



I. Low Voltage Connector

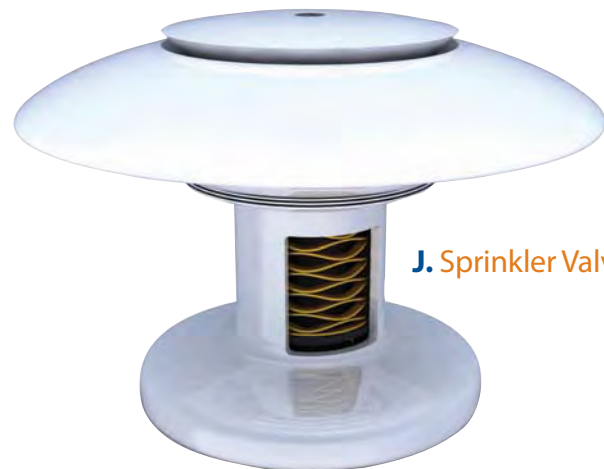

J. Sprinkler Valve

F. Slip Clutch

Clutch drives when the “V”-detents are in the “V”-slots. A Smalley Wave Spring maintains pressure to hold this position. As torque is increased, the “V”-detents will ride up and out the “V”-slots, depressing the wave spring and developing the slip mechanism. When torque is decreased, the wave spring forces the “V”-detents firmly into the “V”-slots to drive again.

G. Bearing Pre-Load

One of the most common wave spring applications world-wide is a bearing preload arrangement as illustrated. Having the proper preload will often extend bearing life by lowering operating temperatures, reducing vibration, minimizing wear and providing for quieter and smoother performance.

H. Flow Valve

As fluid pressure increases the Crest-to-Crest Wave Spring precisely controls the linear displacement of the piston, which positions the orifice for proper fluid flow. Because of the space savings of the Crest-to-Crest design, the valve can be made smaller.

I. Low Voltage Connector

A Bayonet Connector couples as the male end rotates and follows the groove contour in the female end. A 2-Turn Nested Spirawave Wave Spring provides the pre-load between the two halves. A 2-Turn Nested Spring was necessary to develop a higher load in very tight radial and axial space.

J. Sprinkler Valve

With height restrictions accounted for, the Smalley Crest-to-Crest Wave Spring maintains constant pressure on the pop-up head, holding it firmly closed. In operation, water pressure releases the head by overcoming the spring's force.

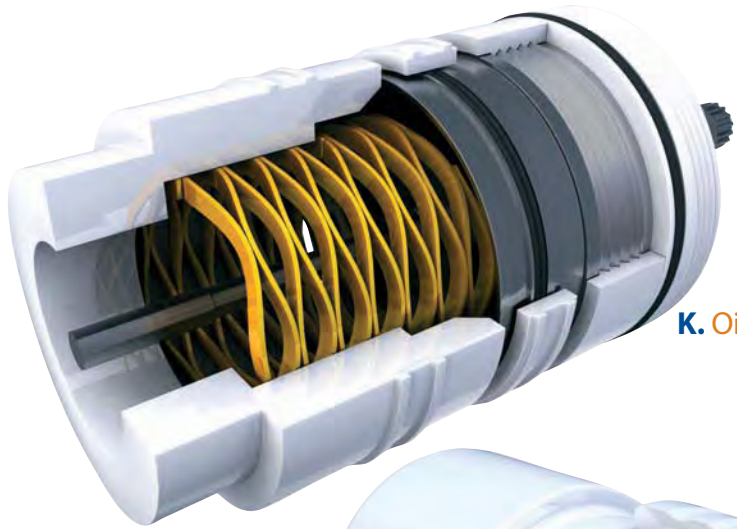

K. Oil Valve

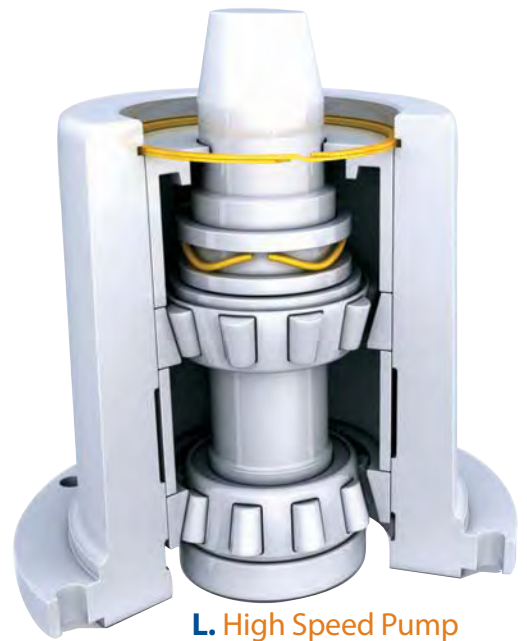

L. High Speed Pump

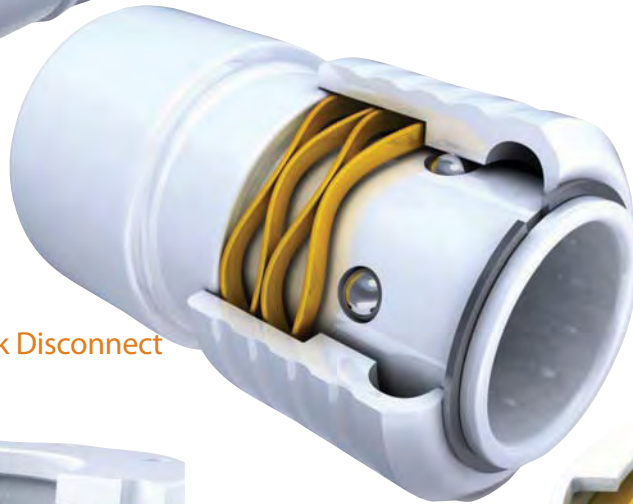

M. Quick Disconnect



N. Vibration Isolator

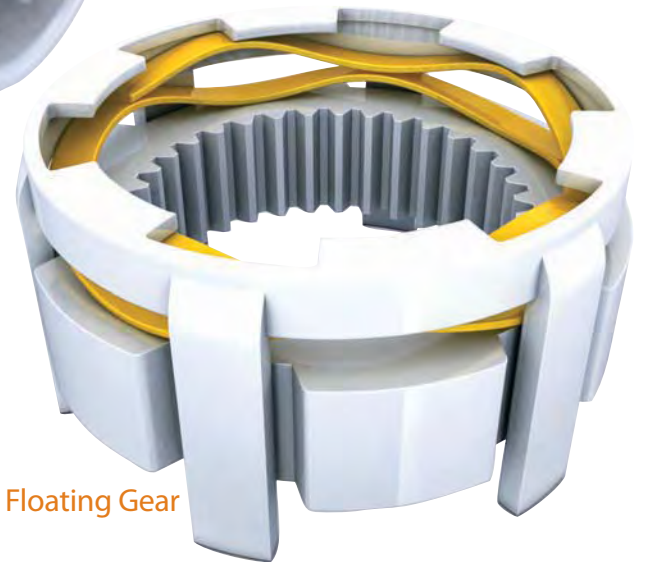

O. Floating Gear

K. Oil Valve

The force provided by the Crest-to-Crest Wave Spring in this oil valve application precisely regulates the amount of oil that is released. The Crest-to-Crest spring provides accurate resistance in a small space, allowing the overall size of the valve to be greatly reduced.

L. High Speed Pump

A Smalley Wavo Spring was specified to provide a higher preload (the force needed was greater than offered with a stock Wave Spring) to the tapered roller bearings. Also, the entire bearing/spindle arrangement is held in its housing by a spiral retaining ring.

M. Quick Disconnect

The sliding member of the disconnect is held in its forward/locked position against the retaining ring, by the Crest-to-Crest Spring. As the user slides the member in the opposite direction compressing the spring, the detent balls align with a groove and release.

N. Vibration Isolator

Wavo Springs provide high force and a relatively large axial displacement, in limited space. The springs are arranged in series for additional travel.

O. Floating Gear

Functioning in a contained bracket, a Crest-to-Crest Wave Spring loads a gear with light force allowing axial movement. The gear shown self-aligns with its mating gear during operation.

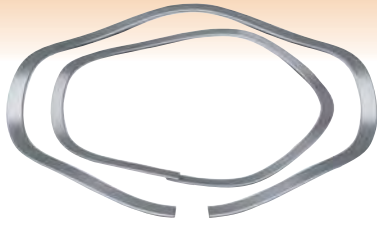

Stock Items in carbon steel and 17-7 PH/C stainless steel. Springs listed below are 3 wave, **Overlap Type**.

Smalley Part Number ^{1,4}	Operates in Bore Diameter	Clears Shaft Diameter	Load (lb)	Work Height	Free Height ²	Number of Waves	Thickness	Radial Wall	Spring Rate ³
SSR-0050	.500	.390	7	.050	.085	3	.008	.040	200
SSR-0062	.625	.480	10	.050	.095	3	.010	.058	222
SSR-0075	.750	.500	14	.062	.160	3	.010	.078	143
SSR-0087	.875	.620	16	.062	.130	3	.012	.094	235
SSR-0100	1.000	.780	18	.062	.160	3	.012	.094	184
SSR-0112	1.125	.840	20	.078	.130	3	.016	.133	385
SSR-0125	1.250	.960	22	.078	.150	3	.016	.133	306
SSR-0137	1.375	1.090	24	.078	.190	3	.016	.133	214
SSR-0150	1.500	1.170	26	.078	.170	3	.018	.143	283
SSR-0162	1.625	1.310	28	.078	.200	3	.018	.143	230

¹ Add suffix "-S17" for 17-7 stainless steel.

² Reference dimension.

³ Theoretical dimension; measured in lb/in.

⁴ See pages 126-127 for How to Order.

OVERLAP TYPE

SSR-0050 to SSR-0162

Product Dimensions

All dimensions in inches unless otherwise specified.

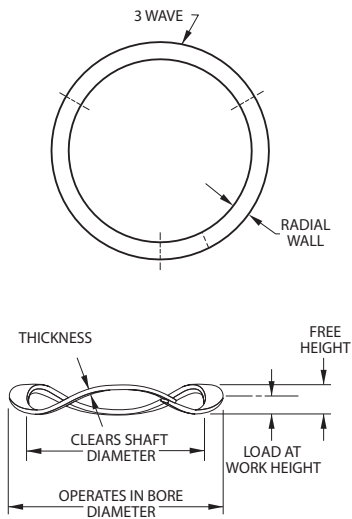

Bayonet Connector

Stock Items in carbon steel and 17-7 PH/C stainless steel. Springs listed below are 4 waves and up, **Gap Type**.

Smalley Part Number ^{1,4}	Operates in Bore Diameter	Clears Shaft Diameter	Load (lb)	Work Height	Free Height ²	Number of Waves	Thickness	Radial Wall	Spring Rate ³
SSR-0175	1.750	1.440	30	.078	.140	4	.018	.143	484
SSR-0187	1.875	1.560	32	.078	.150	4	.018	.143	444
SSR-0200	2.000	1.680	34	.093	.140	4	.024	.150	723
SSR-0212	2.125	1.800	36	.093	.150	4	.024	.150	632
SSR-0225	2.250	1.930	38	.093	.170	4	.024	.150	494
SSR-0237	2.375	1.990	40	.093	.160	4	.024	.178	597
SSR-0250	2.500	2.120	42	.093	.170	4	.024	.178	545
SSR-0262	2.625	2.240	44	.093	.190	4	.024	.178	454
SSR-0275	2.750	2.340	46	.109	.170	4	.030	.188	754
SSR-0287	2.875	2.470	48	.109	.180	4	.030	.188	676
SSR-0300	3.000	2.590	50	.109	.190	4	.030	.188	617
SSR-0312	3.125	2.710	52	.109	.210	4	.030	.188	515
SSR-0325	3.250	2.750	54	.109	.200	4	.030	.233	593
SSR-0337	3.375	2.840	56	.109	.220	4	.030	.233	505
SSR-0350	3.500	3.000	58	.109	.230	4	.030	.233	479
SSR-0362	3.625	3.120	60	.109	.240	4	.030	.233	458
SSR-0375	3.750	3.250	62	.109	.260	4	.030	.233	411
SSR-0387	3.875	3.370	64	.109	.300	4	.030	.233	335
SSR-0400	4.000	3.500	66	.109	.190	5	.030	.233	815
SSR-0412	4.125	3.620	67	.109	.200	5	.030	.233	736
SSR-0425	4.250	3.740	69	.109	.210	5	.030	.233	683
SSR-0437	4.375	3.860	70	.109	.210	5	.030	.233	693
SSR-0450	4.500	3.990	72	.109	.230	5	.030	.233	595
SSR-0462	4.625	4.110	73	.125	.270	5	.030	.233	503
SSR-0475	4.750	4.240	75	.125	.310	5	.030	.233	405
SSR-0487	4.875	4.370	76	.125	.290	5	.030	.233	461
SSR-0500	5.000	4.490	78	.125	.310	5	.030	.233	422
SSR-0512	5.125	4.610	80	.125	.340	5	.030	.233	372
SSR-0525	5.250	4.740	82	.125	.370	5	.030	.233	335
SSR-0537	5.375	4.860	84	.125	.380	5	.030	.233	329
SSR-0550	5.500	4.990	86	.125	.250	6	.030	.233	688
SSR-0562	5.625	5.110	88	.125	.270	6	.030	.233	607
SSR-0575	5.750	5.240	90	.125	.280	6	.030	.233	581
SSR-0587	5.875	5.360	92	.125	.300	6	.030	.233	526
SSR-0600	6.000	5.490	94	.125	.300	6	.030	.233	537
SSR-0612	6.125	5.610	96	.125	.310	6	.030	.233	519
SSR-0625	6.250	5.730	98	.125	.340	6	.030	.233	456
SSR-0637	6.375	5.860	100	.125	.350	6	.030	.233	444
SSR-0650	6.500	5.980	102	.125	.390	6	.030	.233	385
SSR-0675	6.750	6.230	104	.125	.420	6	.030	.233	353
SSR-0700	7.000	6.160	106	.156	.320	6	.032	.375	646
SSR-0725	7.250	6.440	108	.156	.350	6	.032	.375	557
SSR-0750	7.500	6.690	110	.156	.360	6	.032	.375	539
SSR-0775	7.750	6.940	114	.156	.380	6	.032	.375	509
SSR-0800	8.000	7.190	118	.156	.390	6	.032	.375	504
SSR-0825	8.250	7.440	122	.156	.430	6	.032	.375	445
SSR-0850	8.500	7.680	126	.156	.340	7	.032	.375	685
SSR-0875	8.750	7.930	130	.156	.340	7	.032	.375	707
SSR-0900	9.000	8.180	134	.156	.290	8	.032	.375	1,000
SSR-0950	9.500	8.680	142	.156	.240	9	.032	.375	1,690
SSR-1000	10.000	9.170	150	.156	.290	9	.032	.375	1,119
SSR-1050	10.500	9.670	158	.156	.310	9	.032	.375	1,026
SSR-1100	11.000	10.170	166	.156	.350	9	.032	.375	856
SSR-1150	11.500	10.660	174	.156	.360	9	.032	.375	853
SSR-1200	12.000	11.160	182	.156	.440	9	.032	.375	641
SSR-1250	12.500	11.660	190	.156	.350	10	.032	.375	979
SSR-1300	13.000	12.160	198	.156	.410	10	.032	.375	780
SSR-1350	13.500	12.650	206	.156	.430	10	.032	.375	752
SSR-1400	14.000	13.150	214	.156	.300	12	.032	.375	1,486
SSR-1450	14.500	13.650	221	.156	.320	12	.032	.375	1,348
SSR-1500	15.000	14.130	230	.156	.350	12	.032	.375	1,186
SSR-1550	15.500	14.640	239	.156	.310	13	.032	.375	1,552
SSR-1600	16.000	15.140	248	.156	.340	13	.032	.375	1,348

¹ Add suffix "-S17" for 17-7 stainless steel.

² Reference dimension.

³ Theoretical dimension; measured in lb/in.

⁴ See pages 126-127 for How to Order.

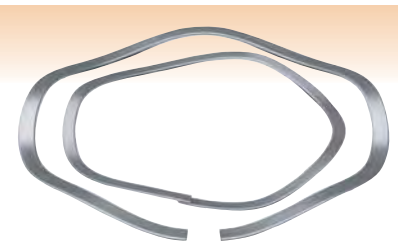

GAP TYPE

SSR-0175 to SSR-1600

Product Dimensions

All dimensions in inches unless otherwise specified.

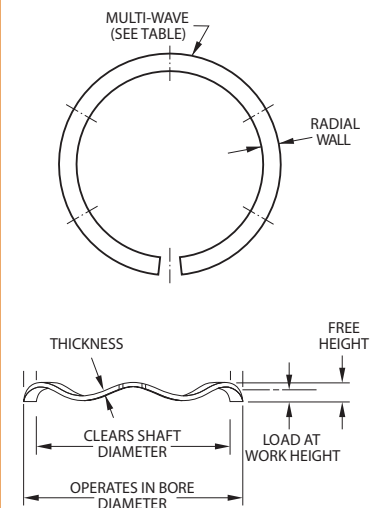

SSR-N Series Narrow Section Wave Springs

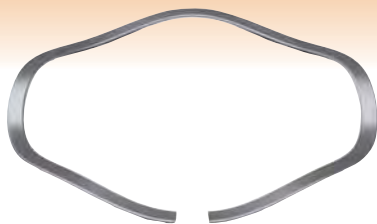

Smalley narrow section wave springs were originally designed to pre-load packings in telescoping hydraulic cylinders. They have also found other applications where working space is highly limited. This Smalley Wave Spring series is designed to fit into a bore with a light snap to assure perfect concentricity between the wave spring and assembly. When these narrow section wave springs are compressed, radial expansion is taken up by the gap in the spring to eliminate binding.

Stock Items in carbon steel and 17-7 PH/C stainless steel. Springs listed below are 4 waves and up, **Gap Type**.

Smalley Part Number ^{1,4}	Operates in Bore Diameter	Clears Shaft Diameter	Load (lb)	Work Height	Free Height ²	Number of Waves	Thickness	Radial Wall	Spring Rate ³
SSR-0325-N	3.250	2.820	54	.109	.200	4	.030	.188	593
SSR-0337-N	3.375	2.940	56	.109	.220	4	.030	.188	505
SSR-0350-N	3.500	3.070	58	.109	.260	4	.030	.188	384
SSR-0362-N	3.625	3.190	60	.109	.270	4	.030	.188	373
SSR-0375-N	3.750	3.320	62	.109	.280	4	.030	.188	363
SSR-0387-N	3.875	3.440	64	.109	.310	4	.030	.188	318
SSR-0400-N	4.000	3.570	66	.109	.200	5	.030	.188	725
SSR-0412-N	4.125	3.690	67	.109	.200	5	.030	.188	736
SSR-0425-N	4.250	3.820	69	.109	.240	5	.030	.188	527
SSR-0437-N	4.375	3.940	70	.109	.210	5	.030	.188	693
SSR-0450-N	4.500	4.070	72	.109	.280	5	.030	.188	421
SSR-0462-N	4.625	4.190	73	.125	.270	5	.030	.188	503
SSR-0475-N	4.750	4.320	75	.125	.320	5	.030	.188	385
SSR-0487-N	4.875	4.440	76	.125	.320	5	.030	.188	390
SSR-0500-N	5.000	4.570	78	.125	.350	5	.030	.188	347
SSR-0512-N	5.125	4.690	80	.125	.350	5	.030	.188	356
SSR-0525-N	5.250	4.820	82	.125	.360	5	.030	.188	349
SSR-0537-N	5.375	4.940	84	.125	.440	5	.030	.188	267
SSR-0550-N	5.500	5.070	86	.125	.280	6	.030	.188	555
SSR-0562-N	5.625	5.190	88	.125	.290	6	.030	.188	533
SSR-0575-N	5.750	5.320	90	.125	.340	6	.030	.188	419
SSR-0587-N	5.875	5.440	92	.125	.340	6	.030	.188	428
SSR-0600-N	6.000	5.570	94	.125	.340	6	.030	.188	437
SSR-0612-N	6.125	5.690	96	.125	.280	7	.030	.188	619
SSR-0625-N	6.250	5.820	98	.125	.280	7	.030	.188	632
SSR-0637-N	6.375	5.940	100	.125	.300	7	.030	.188	571
SSR-0650-N	6.500	6.070	102	.125	.300	7	.030	.188	583
SSR-0675-N	6.750	6.320	104	.125	.300	7	.030	.188	594
SSR-0700-N	7.000	6.480	106	.156	.320	7	.030	.233	646
SSR-0725-N	7.250	6.730	108	.156	.330	7	.030	.233	621
SSR-0750-N	7.500	6.980	110	.156	.360	7	.030	.233	539
SSR-0775-N	7.750	7.230	114	.156	.380	7	.030	.233	509

GAP TYPE

SSR-0325-N to SSR-0775-N

Product Dimensions

All dimensions in inches unless otherwise specified.

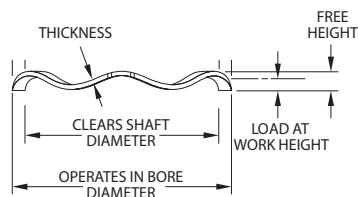
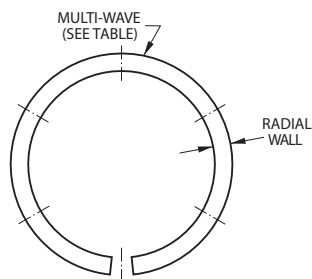

¹ Add suffix "-S17" for 17-7 stainless steel.

² Reference dimension.

³ Theoretical dimension; measured in lb/in.

⁴ See pages 126-127 for How to Order.

Stock Items in carbon and 17-7 PH/C stainless steel.

Smalley Part Number ^{1,4}	Operates in Bore Diameter	Clears Shaft Diameter	Load (lb)	Work Height	Free Height ²	Number of Waves	Wire Diameter	Spring Rate ³
RW-0050	.500	.408	35	.052	.062	3	.031	3,500
RW-0062	.625	.517	50	.064	.077	3	.038	3,846
RW-0075	.750	.628	70	.076	.092	3	.045	4,375
RW-0087	.875	.740	80	.086	.104	3	.051	4,444
RW-0100	1.000	.855	90	.095	.116	3	.056	4,286
RW-0112	1.125	.967	100	.102	.127	3	.060	4,000
RW-0125	1.250	1.081	110	.110	.138	3	.065	3,929
RW-0137	1.375	1.223	120	.095	.121	4	.056	4,615
RW-0150	1.500	1.339	130	.102	.128	4	.060	5,000
RW-0162	1.625	1.444	140	.110	.137	4	.065	5,185
RW-0175	1.750	1.564	150	.113	.144	4	.067	4,839
RW-0187	1.875	1.682	160	.119	.155	4	.070	4,444
RW-0200	2.000	1.803	170	.124	.165	4	.072	4,146
RW-0212	2.125	1.906	180	.129	.162	4	.076	5,455
RW-0225	2.250	2.023	190	.136	.168	4	.080	5,938
RW-0237	2.375	2.141	200	.141	.178	4	.083	5,405
RW-0250	2.500	2.261	210	.144	.185	4	.085	5,122
RW-0262	2.625	2.374	220	.153	.203	4	.090	4,400
RW-0275	2.750	2.497	230	.154	.212	4	.091	3,966
RW-0287	2.875	2.618	240	.158	.210	4	.093	4,615
RW-0300	3.000	2.767	250	.141	.179	5	.083	6,579
RW-0312	3.125	2.878	260	.144	.184	5	.085	6,500
RW-0325	3.250	2.992	270	.153	.190	5	.090	7,297
RW-0337	3.375	3.115	280	.154	.195	5	.091	6,829
RW-0350	3.500	3.236	290	.158	.201	5	.093	6,744
RW-0362	3.625	3.356	300	.161	.206	5	.095	6,667
RW-0375	3.750	3.475	310	.166	.212	5	.098	6,739
RW-0387	3.875	3.595	320	.170	.208	5	.100	8,421
RW-0400	4.000	3.718	330	.170	.225	5	.100	6,000
RW-0412	4.125	3.827	335	.175	.221	5	.105	7,283
RW-0425	4.250	3.948	345	.178	.225	5	.105	7,340
RW-0437	4.375	4.063	350	.187	.240	5	.110	6,604
RW-0450	4.500	4.185	360	.187	.247	5	.110	6,000
RW-0462	4.625	4.310	365	.187	.253	5	.110	5,530
RW-0475	4.750	4.431	375	.190	.257	5	.112	5,597
RW-0487	4.875	4.555	380	.190	.264	5	.112	5,135
RW-0500	5.000	4.672	390	.195	.265	5	.116	5,571
RW-0512	5.125	4.772	400	.200	.274	5	.118	5,405
RW-0525	5.250	4.893	410	.204	.279	5	.120	5,467
RW-0537	5.375	5.037	420	.187	.245	6	.110	7,241
RW-0550	5.500	5.162	430	.187	.251	6	.110	6,719
RW-0562	5.625	5.283	440	.190	.245	6	.112	8,000
RW-0575	5.750	5.406	450	.190	.251	6	.112	7,377
RW-0587	5.875	5.524	460	.197	.262	6	.116	7,077
RW-0600	6.000	5.644	470	.200	.268	6	.118	6,912

¹ Add suffix "-S17" for 17-7 stainless steel.

² Reference dimension.

³ Theoretical dimension; measured in lb/in.

⁴ See pages 126-127 for How to Order.

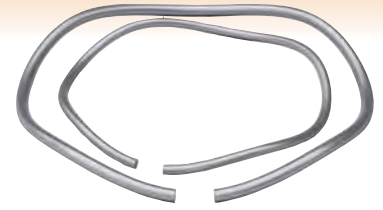

Product Dimensions

All dimensions in inches unless otherwise specified.

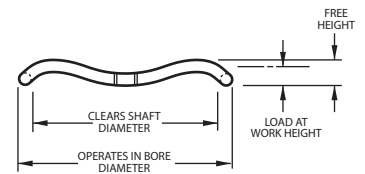
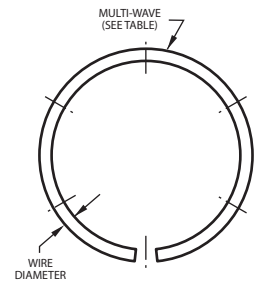

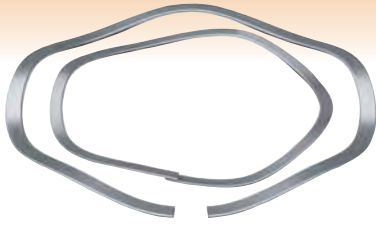

Smalley Circular-Grain bearing preload Wave Springs eliminate play and minimize bearing noise. The constant light/medium pressure they apply removes play between the ball bearings and the bearings' inner and outer races. Preloading can reduce the possibility of bearing damage due to vibration (vibratory loading) and wear due to repetitive and non-repetitive runout.

Stock Items in carbon steel and 17-7 PH/C stainless steel. Springs listed below are 3 and 4 waves **Overlap Type**.

Smalley Part Number ^{1,5}	Bearing O.D. ² (mm)	Clears Shaft Diameter	Load (N)	Work Height	Free Height ³	Number of Waves	Thickness	Radial Wall	Spring Rate ⁴
SSB-0063	16.00	11.28	44.5	1.57	2.29	3	.25	1.98	65
SSB-0075	19.00	14.28	53.4	1.57	3.05	3	.25	1.98	35
SSB-0087	22.00	16.46	62.3	1.57	2.79	3	.30	2.39	48
SSB-0095	24.00	18.46	66.7	1.57	3.56	3	.30	2.39	35
SSB-0102	26.00	18.22	71.2	1.98	2.54	3	.41	3.38	111
SSB-0110	28.00	20.22	75.6	1.98	2.79	3	.41	3.38	85
SSB-0118	30.00	22.22	84.5	1.98	3.30	3	.41	3.38	66
SSB-0126	32.00	24.22	89.0	1.98	3.81	3	.41	3.38	52
SSB-0138	35.00	27.22	97.9	1.98	4.57	3	.41	3.38	38
SSB-0146	37.00	28.72	102.3	1.98	3.81	3	.46	3.63	58
SSB-0158	40.00	31.72	111.2	1.98	5.08	3	.46	3.63	37
SSB-0165	42.00	33.72	115.7	1.98	3.05	4	.46	3.63	99
SSB-0185	47.00	38.72	129.0	1.98	3.81	4	.46	3.63	68
SSB-0205	52.00	43.11	142.4	2.36	3.56	4	.61	3.81	121
SSB-0217	55.00	46.11	151.3	2.36	3.81	4	.61	3.81	100
SSB-0244	62.00	51.69	169.1	2.36	4.32	4	.61	4.52	85
SSB-0268	68.00	57.17	186.9	2.77	4.32	4	.76	4.78	131
SSB-0276	70.00	59.17	191.3	2.77	4.32	4	.76	4.78	119
SSB-0284	72.00	61.17	195.8	2.77	4.57	4	.76	4.78	108
SSB-0295	75.00	64.17	204.7	2.77	5.08	4	.76	4.78	94
SSB-0315	80.00	68.66	218.0	2.77	5.59	4	.76	4.78	76
SSB-0335	85.00	71.38	231.4	2.77	5.59	4	.76	5.92	83
SSB-0354	90.00	76.38	249.2	2.77	6.35	4	.76	5.92	68
SSB-0374	95.00	81.38	262.5	2.77	7.37	4	.76	5.92	57

OVERLAP TYPE

SSB-0063 to SSB-0374

Product Dimensions

All dimensions in millimeters unless otherwise specified.

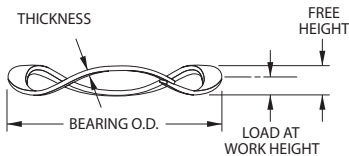
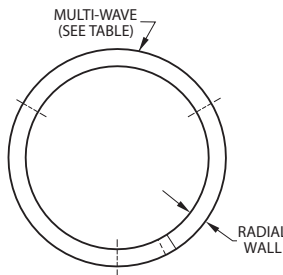
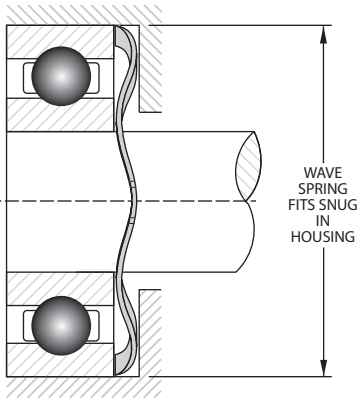

¹ Add suffix "-S17" for 17-7 stainless steel.

² Wave springs fit snug in housing.

³ Reference dimension.

⁴ Theoretical dimension; measured in N/mm.

⁵ See pages 126-127 for How to Order.



Bearing Assembly

Stock Items in carbon steel and 17-7 PH/C stainless steel. Springs listed below are 5 waves and up, **Gap Type**.

Smalley Part Number ^{1,5}	Bearing O.D. ² (mm)	Clears Shaft Diameter	Load (N)	Work Height	Free Height ³	Number of Waves	Thickness	Radial Wall	Spring Rate ⁴
SSB-0394	100.00	86.38	275.9	2.77	4.57	5	.76	5.92	157
SSB-0413	105.00	91.38	289.2	2.77	5.08	5	.76	5.92	134
SSB-0433	110.00	96.38	302.6	2.77	5.33	5	.76	5.92	115
SSB-0453	115.00	101.38	315.9	3.18	6.35	5	.76	5.92	99
SSB-0472	120.00	106.38	329.3	3.18	7.11	5	.76	5.92	86
SSB-0492	125.00	111.38	342.6	3.18	7.62	5	.76	5.92	76
SSB-0512	130.00	116.38	356.0	3.18	8.64	5	.76	5.92	67
SSB-0532	135.00	121.38	369.3	3.18	9.40	5	.76	5.92	59
SSB-0551	140.00	126.38	382.7	3.18	6.86	6	.76	5.92	108
SSB-0571	145.00	131.38	396.0	3.18	7.37	6	.76	5.92	97
SSB-0591	150.00	136.38	404.9	3.18	7.87	6	.76	5.92	87
SSB-0630	160.00	146.38	440.5	3.18	9.40	6	.76	5.92	71
SSB-0650	165.00	151.38	453.9	3.18	10.41	6	.76	5.92	64
SSB-0669	170.00	156.38	467.2	3.18	11.18	6	.76	5.92	58
SSB-0689	175.00	154.16	480.6	3.96	8.13	6	.81	9.53	116
SSB-0709	180.00	159.16	493.9	3.96	8.64	6	.81	9.53	105
SSB-0728	185.00	164.16	507.3	3.96	9.14	6	.81	9.53	97
SSB-0748	190.00	169.16	520.6	3.96	9.91	6	.81	9.53	88
SSB-0787	200.00	179.16	547.3	3.96	7.11	7	.81	9.53	174
SSB-0807	205.00	184.16	560.7	3.96	7.37	7	.81	9.53	161
SSB-0827	210.00	189.16	578.5	3.96	7.87	7	.81	9.53	149
SSB-0847	215.00	194.16	591.8	3.96	8.38	7	.81	9.53	138
SSB-0866	220.00	199.16	605.2	3.96	8.64	7	.81	9.53	128
SSB-0886	225.00	204.16	618.5	3.96	7.11	8	.81	9.53	203
SSB-0906	230.00	209.16	631.9	3.96	6.10	9	.81	9.53	303
SSB-0925	235.00	214.16	645.2	3.96	6.35	9	.81	9.53	283
SSB-0945	240.00	219.16	658.6	3.96	6.35	9	.81	9.53	265
SSB-0984	250.00	229.16	685.3	3.96	6.86	9	.81	9.53	232
SSB-1024	260.00	239.16	712.0	3.96	7.37	9	.81	9.53	205
SSB-1043	265.00	244.16	725.3	3.96	7.62	9	.81	9.53	193
SSB-1063	270.00	249.16	743.1	3.96	8.13	9	.81	9.53	182
SSB-1102	280.00	259.16	769.8	3.96	8.64	9	.81	9.53	162
SSB-1142	290.00	269.16	796.5	3.96	9.40	9	.81	9.53	144
SSB-1181	300.00	279.16	823.2	3.96	10.41	9	.81	9.53	129
SSB-1221	310.00	289.16	849.9	3.96	7.11	9	1.07	9.53	264
SSB-1260	320.00	299.16	876.6	3.96	7.62	9	1.07	9.53	239
SSB-1339	340.00	319.16	934.5	3.96	8.64	9	1.07	9.53	198
SSB-1378	350.00	329.16	961.1	3.96	9.40	9	1.07	9.53	180
SSB-1417	360.00	339.16	987.9	3.96	7.62	10	1.07	9.53	271
SSB-1457	370.00	349.16	1014.6	3.96	8.13	10	1.07	9.53	249
SSB-1496	380.00	359.16	1041.3	3.96	8.64	10	1.07	9.53	229
SSB-1535	390.00	369.16	1072.4	3.96	9.14	10	1.07	9.53	211
SSB-1575	400.00	379.16	1099.1	3.96	9.65	10	1.07	9.53	196
SSB-1614	410.00	382.82	1125.8	3.96	8.38	10	1.07	12.70	251
SSB-1654	420.00	392.82	1152.5	3.96	8.89	10	1.07	12.70	233
SSB-1693	430.00	402.82	1179.2	3.96	7.62	11	1.07	12.70	317
SSB-1732	440.00	412.82	1205.9	3.96	8.13	11	1.07	12.70	295
SSB-1811	460.00	432.82	1263.7	3.96	8.89	11	1.07	12.70	256
SSB-1890	480.00	452.82	1317.1	3.96	8.13	12	1.07	12.70	318
SSB-1969	500.00	472.82	1370.5	3.96	8.89	12	1.07	12.70	280
SSB-2126	540.00	512.82	1481.8	3.96	8.89	13	1.07	12.70	303
SSB-2284	580.00	552.82	1593.0	3.96	8.89	14	1.07	12.70	327

¹ Add suffix "-S17" for 17-7 stainless steel.

² Wave springs fit snug in housing.

³ Reference dimension.

⁴ Theoretical dimension; measured in N/mm.

⁵ See pages 126-127 for How to Order.

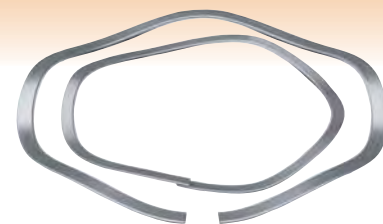

GAP TYPE SSB-0394 to SSB-2284

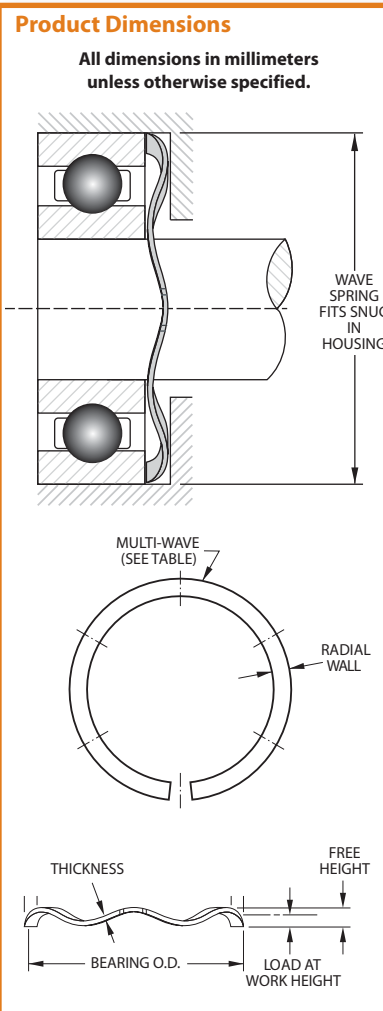

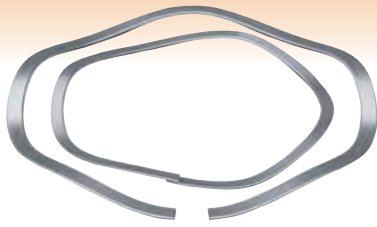

Use this cross-reference guide to select the appropriate Wave Spring for your bearing size. The numbers represent typical standard bearing part numbers and/or the suffix of a standard bearing size.

Stock Items in carbon steel and 17-7 PH/C stainless steel.

Smalley Part Number ^{1,4}	Bearing O.D. ² (mm)	Bearing Part Numbers						
		Extra Small	Extremely Light	Extra Light	Narrow	Light	Medium	Heavy
SSB-0063	16.00	34	—	—	—	—	—	—
SSB-0075	19.00	35, 36	—	—	—	—	—	—
SSB-0087	22.00	37, 38	00	—	—	—	—	—
SSB-0095	24.00	38KV	01	—	—	—	—	—
SSB-0102	26.00	39	—	100	—	—	—	—
SSB-0110	28.00	—	02	101	—	—	—	—
SSB-0118	30.00	—	03	—	—	200	—	—
SSB-0126	32.00	—	—	102	02	201	—	—
SSB-0138	35.00	—	—	103	—	202	300	—
SSB-0146	37.00	—	04	—	03	—	301	—
SSB-0158	40.00	—	—	—	—	203	—	—
SSB-0165	42.00	—	05	104	04	—	302	—
SSB-0185	47.00	—	06	105	—	204	303	—
SSB-0205	52.00	—	—	—	05	205	304	—
SSB-0217	55.00	—	07	106	—	—	—	—
SSB-0244	62.00	—	08	107	06	206	305	403
SSB-0268	68.00	—	09	108	—	—	—	—
SSB-0276	70.00	—	—	—	07	—	—	—
SSB-0284	72.00	—	10	—	—	207	306	404
SSB-0295	75.00	—	—	109	—	—	—	—
SSB-0315	80.00	—	11	110	08	208	307	405
SSB-0335	85.00	—	12	—	09	209	—	—
SSB-0354	90.00	—	13	111	10	210	308	406
SSB-0374	95.00	—	—	112	—	—	—	—
SSB-0394	100.00	—	14	113	11	211	309	407
SSB-0413	105.00	—	15	—	12	—	—	—
SSB-0433	110.00	—	16	114	—	212	310	408
SSB-0453	115.00	—	—	115	13	—	—	—
SSB-0472	120.00	—	17	—	14	213	311	409
SSB-0492	125.00	—	18	116	—	214	—	—
SSB-0512	130.00	—	19	117	15	215	312	410
SSB-0532	135.00	—	—	—	16	—	—	—
SSB-0551	140.00	—	20	118	—	216	313	411
SSB-0571	145.00	—	21	119	17	—	—	—
SSB-0591	150.00	—	22	120	18	217	314	412
SSB-0630	160.00	—	—	121	19	218	315	413
SSB-0650	165.00	—	24	—	20	—	—	—
SSB-0669	170.00	—	—	122	—	219	316	—
SSB-0689	175.00	—	—	—	22 ³	—	—	—
SSB-0709	180.00	—	26	124	21	220	317	414
SSB-0728	185.00	—	—	—	22 ³	—	—	—
SSB-0748	190.00	—	28	—	24	221	318	415
SSB-0787	200.00	—	—	126	—	222	319	416
SSB-0807	205.00	—	—	—	26	—	—	—
SSB-0827	210.00	—	30	128	—	—	—	417
SSB-0847	215.00	—	—	—	—	224	320	—

¹ Add suffix "-S17" for 17-7 stainless steel.

² Wave springs fit snug in housing.

³ Check bearing dimensions.

⁴ See pages 126-127 for How to Order.

Use this cross-reference guide to select the appropriate Wave Spring for your bearing size. The numbers represent typical standard bearing part numbers and/or the suffix of a standard bearing size.

Stock Items in carbon steel and 17-7 PH/C stainless steel.

Smalley Part Number ^{1,4}	Bearing O.D. ² (mm)	Bearing Part Numbers						
		Extra Small	Extremely Light	Extra Light	Narrow	Light	Medium	Heavy
SSB-0866	220.00	—	32	—	28	—	—	—
SSB-0886	225.00	—	—	130	—	—	321	418
SSB-0906	230.00	—	34	—	—	226	—	—
SSB-0925	235.00	—	—	—	30	—	—	—
SSB-0945	240.00	—	—	132	—	—	322	—
SSB-0984	250.00	—	36	—	32	228	—	419
SSB-1024	260.00	—	38	134	—	—	324	—
SSB-1043	265.00	—	—	—	34	—	—	420
SSB-1063	270.00	—	—	—	—	230	—	—
SSB-1102	280.00	—	40	136	36	—	326	—
SSB-1142	290.00	—	—	138	—	232	—	421
SSB-1181	300.00	—	—	—	38	—	328	—
SSB-1221	310.00	—	—	140	—	234	—	—
SSB-1260	320.00	—	—	—	40	236	330	422
SSB-1339	340.00	—	—	144	42	238	332	—
SSB-1378	350.00	—	—	—	44	—	—	—
SSB-1417	360.00	—	—	148	—	240	334	—
SSB-1457	370.00	—	—	—	46	—	—	—
SSB-1496	380.00	—	—	—	—	—	336	—
SSB-1535	390.00	—	—	—	48	—	—	—
SSB-1575	400.00	—	—	152	—	244	338	—
SSB-1614	410.00	—	—	—	50	—	—	—
SSB-1654	420.00	—	—	156	—	—	340	—
SSB-1693	430.00	—	—	—	52	—	—	—
SSB-1732	440.00	—	—	—	—	248	342	—
SSB-1811	460.00	—	—	160	56	—	344	—
SSB-1890	480.00	—	—	164	—	252	—	—
SSB-1969	500.00	—	—	—	64	256	348	—
SSB-2126	540.00	—	—	—	—	260	352	—
SSB-2284	580.00	—	—	—	—	264	356	—

¹ Add suffix "-S17" for 17-7 stainless steel.

² Wave springs fit snug in housing.

³ Check bearing dimensions.

⁴ See pages 126-127 for How to Order.

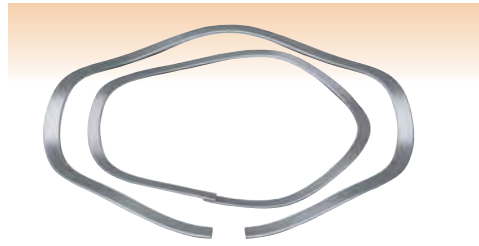



Stock Items in carbon steel and 17-7 PH/C stainless steel.

Smalley Part Number ^{1,2,5}	Operates in Bore Diameter	Clears Shaft Diameter	Load (lb)	Work Height	Free Height ³	Number of Waves	Number of Turns	Thickness	Radial Wall	Spring Rate ⁴
C025-L1*	.250	.150	2	.033	.075	2.5	3	.006	.024	48
C025-L2*	.250	.150	2	.050	.100	2.5	4	.006	.024	40
C025-L3*	.250	.150	2	.060	.125	2.5	5	.006	.024	31
C025-L4*	.250	.150	2	.075	.150	2.5	6	.006	.024	27
C025-L5*	.250	.150	2	.085	.175	2.5	7	.006	.024	22
C025-L6*	.250	.150	2	.095	.200	2.5	8	.006	.024	19
C025-L7*	.250	.150	2	.120	.225	2.5	9	.006	.024	19
C025-L8*	.250	.150	2	.140	.275	2.5	11	.006	.024	15
C025-L9*	.250	.150	2	.170	.325	2.5	13	.006	.024	13
C025-M1*	.250	.150	5	.037	.075	2.5	3	.008	.024	132
C025-M2*	.250	.150	5	.048	.100	2.5	4	.008	.024	96
C025-M3*	.250	.150	5	.065	.125	2.5	5	.008	.024	83
C025-M4*	.250	.150	5	.075	.150	2.5	6	.008	.024	67
C025-M5*	.250	.150	5	.090	.175	2.5	7	.008	.024	59
C025-M6*	.250	.150	5	.100	.200	2.5	8	.008	.024	50
C025-M7*	.250	.150	5	.120	.225	2.5	9	.008	.024	48
C025-M8*	.250	.150	5	.148	.275	2.5	11	.008	.024	39
C025-M9*	.250	.150	5	.175	.325	2.5	13	.008	.024	33
C031-L1	.312	.200	3	.070	.114	2.5	3	.008	.032	68
C031-L2	.312	.200	3	.096	.152	2.5	4	.008	.032	54
C031-L3	.312	.200	3	.118	.190	2.5	5	.008	.032	42
C031-L4	.312	.200	3	.145	.228	2.5	6	.008	.032	36
C031-L5	.312	.200	3	.165	.266	2.5	7	.008	.032	30
C031-L6	.312	.200	3	.195	.304	2.5	8	.008	.032	28
C031-L7	.312	.200	3	.215	.342	2.5	9	.008	.032	24
C031-L8	.312	.200	3	.262	.418	2.5	11	.008	.032	19
C031-L9	.312	.200	3	.309	.494	2.5	13	.008	.032	16
C031-M1	.312	.200	6	.072	.114	2.5	3	.010	.032	143
C031-M2	.312	.200	6	.096	.152	2.5	4	.010	.032	107
C031-M3	.312	.200	6	.123	.190	2.5	5	.010	.032	90
C031-M4	.312	.200	6	.144	.228	2.5	6	.010	.032	71
C031-M5	.312	.200	6	.176	.266	2.5	7	.010	.032	67
C031-M6	.312	.200	6	.197	.304	2.5	8	.010	.032	56
C031-M7	.312	.200	6	.227	.342	2.5	9	.010	.032	52
C031-M8	.312	.200	6	.278	.418	2.5	11	.010	.032	43
C031-M9	.312	.200	6	.336	.494	2.5	13	.010	.032	38
C037-L1	.375	.250	4	.062	.150	2.5	3	.008	.032	45
C037-L2	.375	.250	4	.098	.200	2.5	4	.008	.032	39
C037-L3	.375	.250	4	.108	.250	2.5	5	.008	.032	28
C037-L4	.375	.250	4	.135	.300	2.5	6	.008	.032	24
C037-L5	.375	.250	4	.150	.350	2.5	7	.008	.032	20
C037-L6	.375	.250	4	.184	.400	2.5	8	.008	.032	19
C037-L7	.375	.250	4	.195	.450	2.5	9	.008	.032	16
C037-L8	.375	.250	4	.228	.500	2.5	10	.008	.032	15
C037-L9	.375	.250	4	.240	.550	2.5	11	.008	.032	13
C037-M1	.375	.250	7	.081	.150	2.5	3	.011	.032	101
C037-M2	.375	.250	7	.119	.200	2.5	4	.011	.032	86
C037-M3	.375	.250	7	.145	.250	2.5	5	.011	.032	67
C037-M4	.375	.250	7	.180	.300	2.5	6	.011	.032	58
C037-M5	.375	.250	7	.202	.350	2.5	7	.011	.032	47
C037-M6	.375	.250	7	.240	.400	2.5	8	.011	.032	44
C037-M7	.375	.250	7	.262	.450	2.5	9	.011	.032	37
C037-M8	.375	.250	7	.298	.500	2.5	10	.011	.032	35
C037-M9	.375	.250	7	.327	.550	2.5	11	.011	.032	31

Product Dimensions

All dimensions in inches unless otherwise specified.

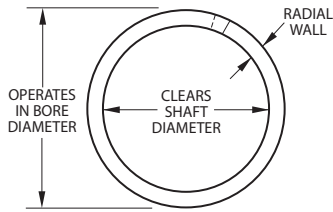

Plain Ends

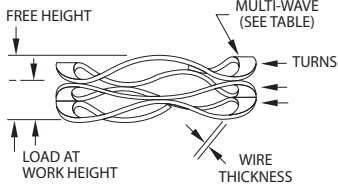

Shim Ends

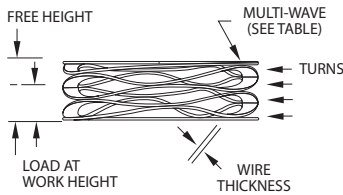

Order Options

C037-L1

End options:

Plain ends **C**
 Squared-shim ends. **CS**

Material option:

Carbon Steel **(blank)**
 Stainless Steel **-S17**

¹ Use "C" prefix for plain ends. Use "CS" prefix for squared-shim ends.

² Add suffix "-S17" for 17-7 stainless steel.

³ Reference dimension.

⁴ Theoretical dimension; measured in lb/in.

⁵ See See pages 126-127 for How to Order.

*Not available with shim ends

Stock Items in carbon steel and 17-7 PH/C stainless steel.

Smalley Part Number ^{1,2,5}	Operates in Bore Diameter	Clears Shaft Diameter	Load (lb)	Work Height	Free Height ³	Number of Waves	Number of Turns	Thickness	Radial Wall	Spring Rate ⁴
C043-L1	.437	.281	4	.063	.165	2.5	3	.008	.040	39
C043-L2	.437	.281	4	.093	.220	2.5	4	.008	.040	31
C043-L3	.437	.281	4	.109	.275	2.5	5	.008	.040	24
C043-L4	.437	.281	4	.143	.330	2.5	6	.008	.040	21
C043-L5	.437	.281	4	.160	.385	2.5	7	.008	.040	18
C043-L6	.437	.281	4	.195	.440	2.5	8	.008	.040	16
C043-L7	.437	.281	4	.210	.495	2.5	9	.008	.040	14
C043-L8	.437	.281	4	.240	.550	2.5	10	.008	.040	13
C043-L9	.437	.281	4	.260	.605	2.5	11	.008	.040	12
C043-M1	.437	.281	8	.082	.165	2.5	3	.011	.046	96
C043-M2	.437	.281	8	.115	.220	2.5	4	.011	.046	76
C043-M3	.437	.281	8	.142	.275	2.5	5	.011	.046	60
C043-M4	.437	.281	8	.179	.330	2.5	6	.011	.046	53
C043-M5	.437	.281	8	.198	.385	2.5	7	.011	.046	43
C043-M6	.437	.281	8	.231	.440	2.5	8	.011	.046	38
C043-M7	.437	.281	8	.255	.495	2.5	9	.011	.046	33
C043-M8	.437	.281	8	.290	.550	2.5	10	.011	.046	31
C043-M9	.437	.281	8	.319	.605	2.5	11	.011	.046	28
C050-L1	.500	.312	5	.062	.180	2.5	3	.008	.056	42
C050-L2	.500	.312	5	.090	.240	2.5	4	.008	.056	33
C050-L3	.500	.312	5	.107	.300	2.5	5	.008	.056	26
C050-L4	.500	.312	5	.136	.360	2.5	6	.008	.056	22
C050-L5	.500	.312	5	.150	.420	2.5	7	.008	.056	19
C050-L6	.500	.312	5	.180	.480	2.5	8	.008	.056	17
C050-L7	.500	.312	5	.195	.540	2.5	9	.008	.056	14
C050-L8	.500	.312	5	.220	.600	2.5	10	.008	.056	13
C050-L9	.500	.312	5	.240	.660	2.5	11	.008	.056	12
C050-M1	.500	.312	10	.065	.180	2.5	3	.010	.058	87
C050-M2	.500	.312	10	.092	.240	2.5	4	.010	.058	68
C050-M3	.500	.312	10	.114	.300	2.5	5	.010	.058	54
C050-M4	.500	.312	10	.147	.360	2.5	6	.010	.058	47
C050-M5	.500	.312	10	.162	.420	2.5	7	.010	.058	39
C050-M6	.500	.312	10	.196	.480	2.5	8	.010	.058	35
C050-M7	.500	.312	10	.207	.540	2.5	9	.010	.058	30
C050-M8	.500	.312	10	.246	.600	2.5	10	.010	.058	28
C050-M9	.500	.312	10	.264	.660	2.5	11	.010	.058	25
C050-H1	.500	.312	15	.075	.180	2.5	3	.012	.060	143
C050-H2	.500	.312	15	.110	.240	2.5	4	.012	.060	115
C050-H3	.500	.312	15	.136	.300	2.5	5	.012	.060	91
C050-H4	.500	.312	15	.167	.360	2.5	6	.012	.060	78
C050-H5	.500	.312	15	.182	.420	2.5	7	.012	.060	63
C050-H6	.500	.312	15	.216	.480	2.5	8	.012	.060	57
C050-H7	.500	.312	15	.240	.540	2.5	9	.012	.060	50
C050-H8	.500	.312	15	.280	.600	2.5	10	.012	.060	47
C050-H9	.500	.312	15	.312	.660	2.5	11	.012	.060	43
C056-L1	.562	.375	5	.080	.195	2.5	3	.009	.058	43
C056-L2	.562	.375	5	.125	.260	2.5	4	.009	.058	37
C056-L3	.562	.375	5	.135	.325	2.5	5	.009	.058	26
C056-L4	.562	.375	5	.180	.390	2.5	6	.009	.058	24
C056-L5	.562	.375	5	.190	.455	2.5	7	.009	.058	19
C056-L6	.562	.375	5	.230	.520	2.5	8	.009	.058	17
C056-L7	.562	.375	5	.260	.585	2.5	9	.009	.058	15
C056-L8	.562	.375	5	.285	.650	2.5	10	.009	.058	14
C056-L9	.562	.375	5	.315	.715	2.5	11	.009	.058	13

¹ Use "C" prefix for plain ends. Use "CS" prefix for squared-shim ends.
² Add suffix "-S17" for 17-7 stainless steel.
³ Reference dimension.
⁴ Theoretical dimension; measured in lb/in.
⁵ See pages 126-127 for How to Order.



Product Dimensions

All dimensions in inches unless otherwise specified.

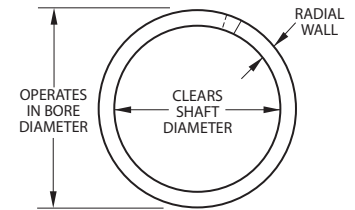

Plain Ends

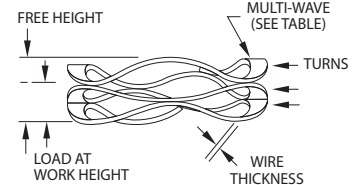

Shim Ends

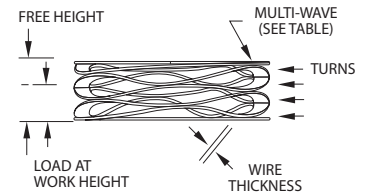

Order Options

C037-L1

End options:

Plain ends **C**
 Squared-shim ends. **CS**

Material option:

Carbon Steel **(blank)**
 Stainless Steel **-S17**



Stock Items in carbon steel and 17-7 PH/C stainless steel.

Smalley Part Number ^{1,2,5}	Operates in Bore Diameter	Clears Shaft Diameter	Load (lb)	Work Height	Free Height ³	Number of Waves	Number of Turns	Thickness	Radial Wall	Spring Rate ⁴
C056-M1	.562	.375	11	.086	.195	2.5	3	.012	.060	101
C056-M2	.562	.375	11	.123	.260	2.5	4	.012	.060	80
C056-M3	.562	.375	11	.145	.325	2.5	5	.012	.060	61
C056-M4	.562	.375	11	.187	.390	2.5	6	.012	.060	54
C056-M5	.562	.375	11	.209	.455	2.5	7	.012	.060	45
C056-M6	.562	.375	11	.253	.520	2.5	8	.012	.060	41
C056-M7	.562	.375	11	.273	.585	2.5	9	.012	.060	35
C056-M8	.562	.375	11	.318	.650	2.5	10	.012	.060	33
C056-M9	.562	.375	11	.343	.715	2.5	11	.012	.060	30
C056-H1	.562	.375	18	.093	.195	2.5	3	.015	.060	176
C056-H2	.562	.375	18	.136	.260	2.5	4	.015	.060	145
C056-H3	.562	.375	18	.165	.325	2.5	5	.015	.060	113
C056-H4	.562	.375	18	.212	.390	2.5	6	.015	.060	101
C056-H5	.562	.375	18	.245	.455	2.5	7	.015	.060	86
C056-H6	.562	.375	18	.282	.520	2.5	8	.015	.060	76
C056-H7	.562	.375	18	.323	.585	2.5	9	.015	.060	69
C056-H8	.562	.375	18	.360	.650	2.5	10	.015	.060	62
C056-H9	.562	.375	18	.408	.715	2.5	11	.015	.060	59
C062-L1	.625	.450	6	.055	.180	2.5	3	.010	.058	48
C062-L2	.625	.450	6	.068	.240	2.5	4	.010	.058	35
C062-L3	.625	.450	6	.085	.300	2.5	5	.010	.058	28
C062-L4	.625	.450	6	.106	.360	2.5	6	.010	.058	24
C062-L5	.625	.450	6	.128	.420	2.5	7	.010	.058	21
C062-L6	.625	.450	6	.165	.540	2.5	9	.010	.058	16
C062-L7	.625	.450	6	.202	.660	2.5	11	.010	.058	13
C062-L8	.625	.450	6	.238	.780	2.5	13	.010	.058	11
C062-M1	.625	.450	12	.104	.180	3.5	3	.010	.058	158
C062-M2	.625	.450	12	.130	.240	3.5	4	.010	.058	109
C062-M3	.625	.450	12	.175	.300	3.5	5	.010	.058	96
C062-M4	.625	.450	12	.206	.360	3.5	6	.010	.058	78
C062-M5	.625	.450	12	.246	.420	3.5	7	.010	.058	69
C062-M6	.625	.450	12	.317	.540	3.5	9	.010	.058	54
C062-M7	.625	.450	12	.386	.660	3.5	11	.010	.058	44
C062-M8	.625	.450	12	.454	.780	3.5	13	.010	.058	37
C062-H1	.625	.450	20	.102	.180	3.5	3	.012	.060	256
C062-H2	.625	.450	20	.135	.240	3.5	4	.012	.060	190
C062-H3	.625	.450	20	.175	.300	3.5	5	.012	.060	160
C062-H4	.625	.450	20	.205	.360	3.5	6	.012	.060	129
C062-H5	.625	.450	20	.245	.420	3.5	7	.012	.060	114
C062-H6	.625	.450	20	.315	.540	3.5	9	.012	.060	89
C062-H7	.625	.450	20	.390	.660	3.5	11	.012	.060	74
C062-H8	.625	.450	20	.465	.780	3.5	13	.012	.060	63
C075-L1	.750	.550	7	.142	.250	3.5	3	.008	.071	65
C075-L2	.750	.550	7	.187	.333	3.5	4	.008	.071	48
C075-L3	.750	.550	7	.246	.417	3.5	5	.008	.071	41
C075-L4	.750	.550	7	.285	.500	3.5	6	.008	.071	33
C075-L5	.750	.550	7	.348	.583	3.5	7	.008	.071	30
C075-L6	.750	.550	7	.446	.750	3.5	9	.008	.071	23
C075-L7	.750	.550	7	.580	1.000	3.5	12	.008	.071	17
C075-M1	.750	.550	13	.159	.250	3.5	3	.010	.078	143
C075-M2	.750	.550	13	.203	.333	3.5	4	.010	.078	100
C075-M3	.750	.550	13	.270	.417	3.5	5	.010	.078	88
C075-M4	.750	.550	13	.314	.500	3.5	6	.010	.078	70
C075-M5	.750	.550	13	.381	.583	3.5	7	.010	.078	64
C075-M6	.750	.550	13	.489	.750	3.5	9	.010	.078	50
C075-M7	.750	.550	13	.649	1.000	3.5	12	.010	.078	37
C075-H1	.750	.550	22	.169	.250	3.5	3	.013	.079	272
C075-H2	.750	.550	22	.215	.333	3.5	4	.013	.079	186
C075-H3	.750	.550	22	.291	.417	3.5	5	.013	.079	175
C075-H4	.750	.550	22	.335	.500	3.5	6	.013	.079	133
C075-H5	.750	.550	22	.405	.583	3.5	7	.013	.079	124
C075-H6	.750	.550	22	.526	.750	3.5	9	.013	.079	98
C075-H7	.750	.550	22	.699	1.000	3.5	12	.013	.079	73

Product Dimensions

All dimensions in inches unless otherwise specified.

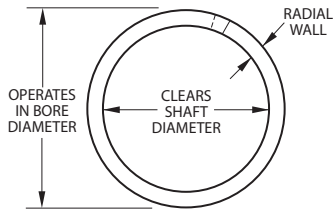

Plain Ends

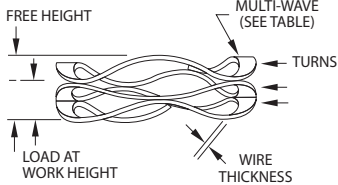

Shim Ends

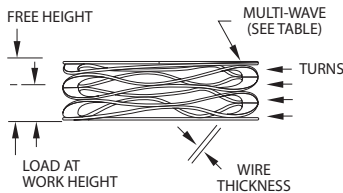

Order Options

C037-L1

End options:

Plain ends **C**
 Squared-shim ends. **CS**

Material option:

Carbon Steel **(blank)**
 Stainless Steel **-S17**

¹ Use "C" prefix for plain ends. Use "CS" prefix for squared-shim ends.

² Add suffix "-S17" for 17-7 stainless steel.

³ Reference dimension.

⁴ Theoretical dimension; measured in lb/in.

⁵ See pages 126-127 for How to Order.

Stock Items in carbon steel and 17-7 PH/C stainless steel.

Smalley Part Number ^{1,2,5}	Operates in Bore Diameter	Clears Shaft Diameter	Load (lb)	Work Height	Free Height ³	Number of Waves	Number of Turns	Thickness	Radial Wall	Spring Rate ⁴
C087-L1	.875	.600	12	.117	.250	3.5	3	.010	.086	90
C087-L2	.875	.600	12	.158	.333	3.5	4	.010	.086	69
C087-L3	.875	.600	12	.207	.417	3.5	5	.010	.086	57
C087-L4	.875	.600	12	.242	.500	3.5	6	.010	.086	47
C087-L5	.875	.600	12	.287	.583	3.5	7	.010	.086	41
C087-L6	.875	.600	12	.378	.750	3.5	9	.010	.086	32
C087-L7	.875	.600	12	.498	1.000	3.5	12	.010	.086	24
C087-M1	.875	.600	18	.124	.250	3.5	3	.012	.094	148
C087-M2	.875	.600	18	.164	.333	3.5	4	.012	.094	108
C087-M3	.875	.600	18	.214	.417	3.5	5	.012	.094	89
C087-M4	.875	.600	18	.252	.500	3.5	6	.012	.094	76
C087-M5	.875	.600	18	.296	.583	3.5	7	.012	.094	66
C087-M6	.875	.600	18	.385	.750	3.5	9	.012	.094	50
C087-M7	.875	.600	18	.509	1.000	3.5	12	.012	.094	38
C087-H1	.875	.600	25	.166	.250	3.5	3	.015	.094	298
C087-H2	.875	.600	25	.214	.333	3.5	4	.015	.094	210
C087-H3	.875	.600	25	.278	.417	3.5	5	.015	.094	180
C087-H4	.875	.600	25	.327	.500	3.5	6	.015	.094	145
C087-H5	.875	.600	25	.395	.583	3.5	7	.015	.094	133
C087-H6	.875	.600	25	.510	.750	3.5	9	.015	.094	104
C087-H7	.875	.600	25	.670	1.000	3.5	12	.015	.094	78
C100-L1	1.000	.730	12	.084	.250	3.5	3	.010	.086	72
C100-L2	1.000	.730	12	.108	.333	3.5	4	.010	.086	53
C100-L3	1.000	.730	12	.145	.417	3.5	5	.010	.086	44
C100-L4	1.000	.730	12	.165	.500	3.5	6	.010	.086	36
C100-L5	1.000	.730	12	.201	.583	3.5	7	.010	.086	31
C100-L6	1.000	.730	12	.258	.750	3.5	9	.010	.086	24
C100-L7	1.000	.730	12	.342	1.000	3.5	12	.010	.086	18
C100-L8	1.000	.730	12	.445	1.250	3.5	15	.010	.086	15
C100-L9	1.000	.730	12	.519	1.500	3.5	18	.010	.086	12
C100-L10	1.000	.730	12	.633	1.750	3.5	21	.010	.086	11
C100-L11	1.000	.730	12	.710	2.000	3.5	24	.010	.086	9
C100-M1	1.000	.730	18	.087	.250	3.5	3	.012	.094	110
C100-M2	1.000	.730	18	.113	.333	3.5	4	.012	.094	82
C100-M3	1.000	.730	18	.148	.417	3.5	5	.012	.094	67
C100-M4	1.000	.730	18	.175	.500	3.5	6	.012	.094	55
C100-M5	1.000	.730	18	.212	.583	3.5	7	.012	.094	49
C100-M6	1.000	.730	18	.276	.750	3.5	9	.012	.094	38
C100-M7	1.000	.730	18	.360	1.000	3.5	12	.012	.094	28
C100-M8	1.000	.730	18	.452	1.250	3.5	15	.012	.094	23
C100-M9	1.000	.730	18	.549	1.500	3.5	18	.012	.094	19
C100-M10	1.000	.730	18	.650	1.750	3.5	21	.012	.094	16
C100-M11	1.000	.730	18	.720	2.000	3.5	24	.012	.094	14
C100-H1	1.000	.730	25	.131	.250	3.5	3	.015	.094	210
C100-H2	1.000	.730	25	.174	.333	3.5	4	.015	.094	157
C100-H3	1.000	.730	25	.227	.417	3.5	5	.015	.094	132
C100-H4	1.000	.730	25	.266	.500	3.5	6	.015	.094	107
C100-H5	1.000	.730	25	.319	.583	3.5	7	.015	.094	95
C100-H6	1.000	.730	25	.406	.750	3.5	9	.015	.094	73
C100-H7	1.000	.730	25	.541	1.000	3.5	12	.015	.094	54
C100-H8	1.000	.730	25	.688	1.250	3.5	15	.015	.094	45
C100-H9	1.000	.730	25	.813	1.500	3.5	18	.015	.094	36
C100-H10	1.000	.730	25	.957	1.750	3.5	21	.015	.094	32
C100-H11	1.000	.730	25	1.083	2.000	3.5	24	.015	.094	27

¹ Use "C" prefix for plain ends. Use "CS" prefix for squared-shim ends.
² Add suffix "-S17" for 17-7 stainless steel.
³ Reference dimension.
⁴ Theoretical dimension; measured in lb/in.
⁵ See pages 126-127 for How to Order.



Product Dimensions

All dimensions in inches unless otherwise specified.

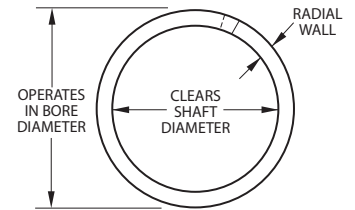

Plain Ends

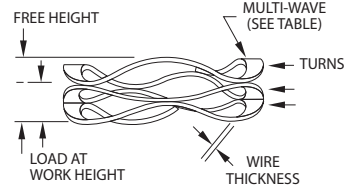

Shim Ends

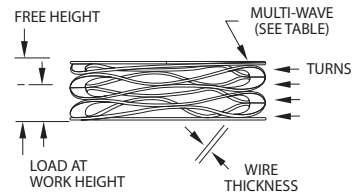

Order Options

C037-L1

End options:

Plain ends **C**
 Squared-shim ends. **CS**

Material option:

Carbon Steel (blank)
 Stainless Steel **-S17**



Stock Items in carbon steel and 17-7 PH/C stainless steel.

Smalley Part Number ^{1,2,5}	Operates in Bore Diameter	Clears Shaft Diameter	Load (lb)	Work Height	Free Height ³	Number of Waves	Number of Turns	Thickness	Radial Wall	Spring Rate ⁴
C112-L1	1.125	.850	12	.146	.300	3.5	3	.012	.094	78
C112-L2	1.125	.850	12	.186	.400	3.5	4	.012	.094	56
C112-L3	1.125	.850	12	.250	.500	3.5	5	.012	.094	48
C112-L4	1.125	.850	12	.295	.600	3.5	6	.012	.094	39
C112-L5	1.125	.850	12	.344	.700	3.5	7	.012	.094	34
C112-L6	1.125	.850	12	.392	.800	3.5	8	.012	.094	29
C112-L7	1.125	.850	12	.488	1.000	3.5	10	.012	.094	23
C112-L8	1.125	.850	12	.659	1.300	3.5	13	.012	.094	19
C112-L9	1.125	.850	12	.807	1.600	3.5	16	.012	.094	15
C112-L10	1.125	.850	12	1.017	2.000	3.5	20	.012	.094	12
C112-M1	1.125	.850	20	.160	.300	3.5	3	.015	.094	143
C112-M2	1.125	.850	20	.202	.400	3.5	4	.015	.094	101
C112-M3	1.125	.850	20	.270	.500	3.5	5	.015	.094	87
C112-M4	1.125	.850	20	.318	.600	3.5	6	.015	.094	71
C112-M5	1.125	.850	20	.381	.700	3.5	7	.015	.094	63
C112-M6	1.125	.850	20	.427	.800	3.5	8	.015	.094	54
C112-M7	1.125	.850	20	.536	1.000	3.5	10	.015	.094	43
C112-M8	1.125	.850	20	.708	1.300	3.5	13	.015	.094	34
C112-M9	1.125	.850	20	.861	1.600	3.5	16	.015	.094	27
C112-M10	1.125	.850	20	1.088	2.000	3.5	20	.015	.094	22
C112-H1	1.125	.850	30	.178	.300	3.5	3	.018	.094	246
C112-H2	1.125	.850	30	.229	.400	3.5	4	.018	.094	175
C112-H3	1.125	.850	30	.303	.500	3.5	5	.018	.094	152
C112-H4	1.125	.850	30	.350	.600	3.5	6	.018	.094	120
C112-H5	1.125	.850	30	.421	.700	3.5	7	.018	.094	108
C112-H6	1.125	.850	30	.470	.800	3.5	8	.018	.094	91
C112-H7	1.125	.850	30	.593	1.000	3.5	10	.018	.094	74
C112-H8	1.125	.850	30	.787	1.300	3.5	13	.018	.094	58
C112-H9	1.125	.850	30	.956	1.600	3.5	16	.018	.094	47
C112-H10	1.125	.850	30	1.202	2.000	3.5	20	.018	.094	38
C125-L1	1.250	1.000	12	.084	.300	3.5	3	.012	.094	56
C125-L2	1.250	1.000	12	.113	.400	3.5	4	.012	.094	42
C125-L3	1.250	1.000	12	.149	.500	3.5	5	.012	.094	34
C125-L4	1.250	1.000	12	.172	.600	3.5	6	.012	.094	28
C125-L5	1.250	1.000	12	.207	.700	3.5	7	.012	.094	24
C125-L6	1.250	1.000	12	.227	.800	3.5	8	.012	.094	21
C125-L7	1.250	1.000	12	.301	1.000	3.5	10	.012	.094	17
C125-L8	1.250	1.000	12	.395	1.300	3.5	13	.012	.094	13
C125-L9	1.250	1.000	12	.467	1.600	3.5	16	.012	.094	11
C125-L10	1.250	1.000	12	.591	2.000	3.5	20	.012	.094	9
C125-M1	1.250	1.000	20	.124	.300	3.5	3	.015	.094	114
C125-M2	1.250	1.000	20	.165	.400	3.5	4	.015	.094	85
C125-M3	1.250	1.000	20	.215	.500	3.5	5	.015	.094	70
C125-M4	1.250	1.000	20	.253	.600	3.5	6	.015	.094	58
C125-M5	1.250	1.000	20	.303	.700	3.5	7	.015	.094	50
C125-M6	1.250	1.000	20	.341	.800	3.5	8	.015	.094	44
C125-M7	1.250	1.000	20	.427	1.000	3.5	10	.015	.094	35
C125-M8	1.250	1.000	20	.577	1.300	3.5	13	.015	.094	28
C125-M9	1.250	1.000	20	.692	1.600	3.5	16	.015	.094	22
C125-M10	1.250	1.000	20	.866	2.000	3.5	20	.015	.094	18
C125-H1	1.250	1.000	30	.158	.300	3.5	3	.019	.094	210
C125-H2	1.250	1.000	30	.210	.400	3.5	4	.019	.094	158
C125-H3	1.250	1.000	30	.272	.500	3.5	5	.019	.094	132
C125-H4	1.250	1.000	30	.320	.600	3.5	6	.019	.094	107
C125-H5	1.250	1.000	30	.384	.700	3.5	7	.019	.094	95
C125-H6	1.250	1.000	30	.433	.800	3.5	8	.019	.094	82
C125-H7	1.250	1.000	30	.538	1.000	3.5	10	.019	.094	65
C125-H8	1.250	1.000	30	.717	1.300	3.5	13	.019	.094	51
C125-H9	1.250	1.000	30	.878	1.600	3.5	16	.019	.094	42
C125-H10	1.250	1.000	30	1.103	2.000	3.5	20	.019	.094	33

Product Dimensions

All dimensions in inches unless otherwise specified.

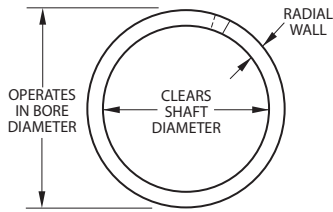

Plain Ends

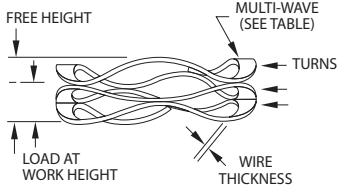

Shim Ends

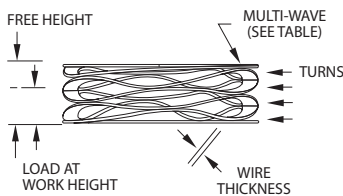

Order Options

C037-L1

End options:

Plain ends **C**
 Squared-shim ends. **CS**

Material option:

Carbon Steel **(blank)**
 Stainless Steel **-S17**

¹ Use "C" prefix for plain ends. Use "CS" prefix for squared-shim ends.

² Add suffix "-S17" for 17-7 stainless steel.

³ Reference dimension.

⁴ Theoretical dimension; measured in lb/in.

⁵ See pages 126-127 for How to Order.

Stock Items in carbon steel and 17-7 PH/C stainless steel.

Smalley Part Number ^{1,2,5}	Operates in Bore Diameter	Clears Shaft Diameter	Load (lb)	Work Height	Free Height ³	Number of Waves	Number of Turns	Thickness	Radial Wall	Spring Rate ⁴
C137-L1	1.375	1.030	15	.075	.300	3.5	3	.012	.122	67
C137-L2	1.375	1.030	15	.099	.400	3.5	4	.012	.122	50
C137-L3	1.375	1.030	15	.129	.500	3.5	5	.012	.122	40
C137-L4	1.375	1.030	15	.155	.600	3.5	6	.012	.122	34
C137-L5	1.375	1.030	15	.179	.700	3.5	7	.012	.122	29
C137-L6	1.375	1.030	15	.206	.800	3.5	8	.012	.122	25
C137-L7	1.375	1.030	15	.256	1.000	3.5	10	.012	.122	20
C137-L8	1.375	1.030	15	.341	1.300	3.5	13	.012	.122	16
C137-L9	1.375	1.030	15	.424	1.600	3.5	16	.012	.122	13
C137-L10	1.375	1.030	15	.530	2.000	3.5	20	.012	.122	10
C137-M1	1.375	1.030	25	.142	.300	3.5	3	.016	.133	158
C137-M2	1.375	1.030	25	.186	.400	3.5	4	.016	.133	117
C137-M3	1.375	1.030	25	.240	.500	3.5	5	.016	.133	96
C137-M4	1.375	1.030	25	.281	.600	3.5	6	.016	.133	78
C137-M5	1.375	1.030	25	.340	.700	3.5	7	.016	.133	69
C137-M6	1.375	1.030	25	.384	.800	3.5	8	.016	.133	60
C137-M7	1.375	1.030	25	.486	1.000	3.5	10	.016	.133	49
C137-M8	1.375	1.030	25	.632	1.300	3.5	13	.016	.133	37
C137-M9	1.375	1.030	25	.788	1.600	3.5	16	.016	.133	31
C137-M10	1.375	1.030	25	.982	2.000	3.5	20	.016	.133	25
C137-H1	1.375	1.030	35	.149	.300	3.5	3	.018	.133	232
C137-H2	1.375	1.030	35	.189	.400	3.5	4	.018	.133	166
C137-H3	1.375	1.030	35	.247	.500	3.5	5	.018	.133	138
C137-H4	1.375	1.030	35	.287	.600	3.5	6	.018	.133	112
C137-H5	1.375	1.030	35	.343	.700	3.5	7	.018	.133	98
C137-H6	1.375	1.030	35	.390	.800	3.5	8	.018	.133	85
C137-H7	1.375	1.030	35	.490	1.000	3.5	10	.018	.133	69
C137-H8	1.375	1.030	35	.646	1.300	3.5	13	.018	.133	54
C137-H9	1.375	1.030	35	.793	1.600	3.5	16	.018	.133	43
C137-H10	1.375	1.030	35	1.000	2.000	3.5	20	.018	.133	35
C150-L1	1.500	1.140	20	.129	.300	3.5	3	.016	.133	117
C150-L2	1.500	1.140	20	.164	.400	3.5	4	.016	.133	85
C150-L3	1.500	1.140	20	.213	.500	3.5	5	.016	.133	70
C150-L4	1.500	1.140	20	.247	.600	3.5	6	.016	.133	57
C150-L5	1.500	1.140	20	.301	.700	3.5	7	.016	.133	50
C150-L6	1.500	1.140	20	.337	.800	3.5	8	.016	.133	43
C150-L7	1.500	1.140	20	.430	1.000	3.5	10	.016	.133	35
C150-L8	1.500	1.140	20	.565	1.300	3.5	13	.016	.133	27
C150-L9	1.500	1.140	20	.694	1.600	3.5	16	.016	.133	22
C150-L10	1.500	1.140	20	.866	2.000	3.5	20	.016	.133	18
C150-M1	1.500	1.140	35	.122	.300	3.5	3	.018	.133	197
C150-M2	1.500	1.140	35	.158	.400	3.5	4	.018	.133	145
C150-M3	1.500	1.140	35	.206	.500	3.5	5	.018	.133	119
C150-M4	1.500	1.140	35	.241	.600	3.5	6	.018	.133	97
C150-M5	1.500	1.140	35	.291	.700	3.5	7	.018	.133	86
C150-M6	1.500	1.140	35	.324	.800	3.5	8	.018	.133	74
C150-M7	1.500	1.140	35	.409	1.000	3.5	10	.018	.133	59
C150-M8	1.500	1.140	35	.540	1.300	3.5	13	.018	.133	46
C150-M9	1.500	1.140	35	.657	1.600	3.5	16	.018	.133	37
C150-M10	1.500	1.140	35	.835	2.000	3.5	20	.018	.133	30
C150-H1	1.500	1.140	60	.166	.300	4.5	3	.018	.133	448
C150-H2	1.500	1.140	60	.216	.400	4.5	4	.018	.133	326
C150-H3	1.500	1.140	60	.278	.500	4.5	5	.018	.133	270
C150-H4	1.500	1.140	60	.329	.600	4.5	6	.018	.133	221
C150-H5	1.500	1.140	60	.390	.700	4.5	7	.018	.133	194
C150-H6	1.500	1.140	60	.443	.800	4.5	8	.018	.133	168
C150-H7	1.500	1.140	60	.555	1.000	4.5	10	.018	.133	135
C150-H8	1.500	1.140	60	.726	1.300	4.5	13	.018	.133	105
C150-H9	1.500	1.140	60	.890	1.600	4.5	16	.018	.133	85
C150-H10	1.500	1.140	60	1.119	2.000	4.5	20	.018	.133	68

¹ Use "C" prefix for plain ends. Use "CS" prefix for squared-shim ends.

² Add suffix "-S17" for 17-7 stainless steel.

³ Reference dimension.

⁴ Theoretical dimension; measured in lb/in.

⁵ See pages 126-127 for How to Order.



Product Dimensions

All dimensions in inches unless otherwise specified.

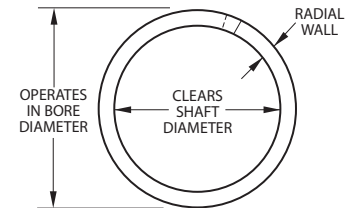

Plain Ends

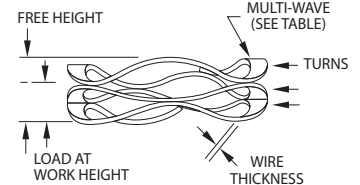

Shim Ends

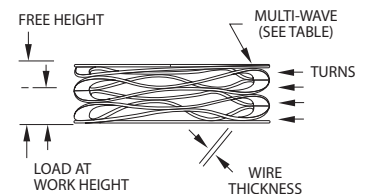

Order Options

C037-L1

End options:
 Plain ends C
 Squared-shim ends CS

Material option:
 Carbon Steel (blank)
 Stainless Steel -S17



Stock Items in carbon steel and 17-7 PH/C stainless steel.

Smalley Part Number ^{1,2,5}	Operates in Bore Diameter	Clears Shaft Diameter	Load (lb)	Work Height	Free Height ³	Number of Waves	Number of Turns	Thickness	Radial Wall	Spring Rate ⁴
C175-L1	1.750	1.340	25	.155	.375	3.5	3	.018	.143	114
C175-L2	1.750	1.340	25	.200	.500	3.5	4	.018	.143	83
C175-L3	1.750	1.340	25	.265	.625	3.5	5	.018	.143	69
C175-L4	1.750	1.340	25	.310	.750	3.5	6	.018	.143	57
C175-L5	1.750	1.340	25	.367	.870	3.5	7	.018	.143	50
C175-L6	1.750	1.340	25	.415	1.000	3.5	8	.018	.143	43
C175-L7	1.750	1.340	25	.523	1.250	3.5	10	.018	.143	34
C175-L8	1.750	1.340	25	.638	1.500	3.5	12	.018	.143	29
C175-L9	1.750	1.340	25	.737	1.750	3.5	14	.018	.143	25
C175-L10	1.750	1.340	25	.844	2.000	3.5	16	.018	.143	22
C175-M1	1.750	1.340	50	.188	.375	4.5	3	.018	.143	267
C175-M2	1.750	1.340	50	.244	.500	4.5	4	.018	.143	195
C175-M3	1.750	1.340	50	.315	.625	4.5	5	.018	.143	161
C175-M4	1.750	1.340	50	.374	.750	4.5	6	.018	.143	133
C175-M5	1.750	1.340	50	.452	.870	4.5	7	.018	.143	120
C175-M6	1.750	1.340	50	.505	1.000	4.5	8	.018	.143	101
C175-M7	1.750	1.340	50	.629	1.250	4.5	10	.018	.143	81
C175-M8	1.750	1.340	50	.768	1.500	4.5	12	.018	.143	68
C175-M9	1.750	1.340	50	.899	1.750	4.5	14	.018	.143	59
C175-M10	1.750	1.340	50	1.026	2.000	4.5	16	.018	.143	51
C175-H1	1.750	1.340	90	.232	.375	4.5	3	.024	.148	629
C175-H2	1.750	1.340	90	.314	.500	4.5	4	.024	.148	484
C175-H3	1.750	1.340	90	.409	.625	4.5	5	.024	.148	417
C175-H4	1.750	1.340	90	.482	.750	4.5	6	.024	.148	336
C175-H5	1.750	1.340	90	.577	.870	4.5	7	.024	.148	307
C175-H6	1.750	1.340	90	.651	1.000	4.5	8	.024	.148	258
C175-H7	1.750	1.340	90	.813	1.250	4.5	10	.024	.148	206
C175-H8	1.750	1.340	90	.980	1.500	4.5	12	.024	.148	173
C175-H9	1.750	1.340	90	1.147	1.750	4.5	14	.024	.148	149
C175-H10	1.750	1.340	90	1.317	2.000	4.5	16	.024	.148	132
C200-L1	2.000	1.600	25	.094	.375	3.5	3	.018	.143	89
C200-L2	2.000	1.600	25	.120	.500	3.5	4	.018	.143	66
C200-L3	2.000	1.600	25	.158	.625	3.5	5	.018	.143	54
C200-L4	2.000	1.600	25	.179	.750	3.5	6	.018	.143	44
C200-L5	2.000	1.600	25	.217	.870	3.5	7	.018	.143	38
C200-L6	2.000	1.600	25	.243	1.000	3.5	8	.018	.143	33
C200-L7	2.000	1.600	25	.306	1.250	3.5	10	.018	.143	26
C200-L8	2.000	1.600	25	.365	1.500	3.5	12	.018	.143	22
C200-L9	2.000	1.600	25	.433	1.750	3.5	14	.018	.143	19
C200-L10	2.000	1.600	25	.490	2.000	3.5	16	.018	.143	17
C200-M1	2.000	1.600	50	.140	.375	4.5	3	.018	.143	213
C200-M2	2.000	1.600	50	.184	.500	4.5	4	.018	.143	158
C200-M3	2.000	1.600	50	.245	.625	4.5	5	.018	.143	132
C200-M4	2.000	1.600	50	.278	.750	4.5	6	.018	.143	106
C200-M5	2.000	1.600	50	.345	.870	4.5	7	.018	.143	95
C200-M6	2.000	1.600	50	.395	1.000	4.5	8	.018	.143	83
C200-M7	2.000	1.600	50	.498	1.250	4.5	10	.018	.143	66
C200-M8	2.000	1.600	50	.593	1.500	4.5	12	.018	.143	55
C200-M9	2.000	1.600	50	.694	1.750	4.5	14	.018	.143	47
C200-M10	2.000	1.600	50	.800	2.000	4.5	16	.018	.143	42
C200-H1	2.000	1.600	90	.197	.375	4.5	3	.024	.148	506
C200-H2	2.000	1.600	90	.258	.500	4.5	4	.024	.148	372
C200-H3	2.000	1.600	90	.332	.625	4.5	5	.024	.148	307
C200-H4	2.000	1.600	90	.389	.750	4.5	6	.024	.148	249
C200-H5	2.000	1.600	90	.465	.870	4.5	7	.024	.148	222
C200-H6	2.000	1.600	90	.525	1.000	4.5	8	.024	.148	189
C200-H7	2.000	1.600	90	.661	1.250	4.5	10	.024	.148	153
C200-H8	2.000	1.600	90	.781	1.500	4.5	12	.024	.148	125
C200-H9	2.000	1.600	90	.941	1.750	4.5	14	.024	.148	111
C200-H10	2.000	1.600	90	1.069	2.000	4.5	16	.024	.148	97

Product Dimensions

All dimensions in inches unless otherwise specified.

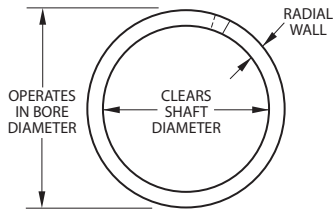

Plain Ends

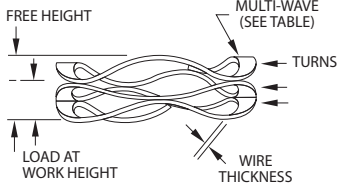

Shim Ends

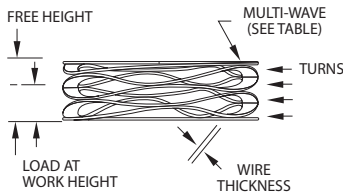

Order Options

C037-L1

End options:

Plain ends **C**
 Squared-shim ends. **CS**

Material option:

Carbon Steel (blank)
 Stainless Steel **-S17**

¹ Use "C" prefix for plain ends. Use "CS" prefix for squared-shim ends.

² Add suffix "-S17" for 17-7 stainless steel.

³ Reference dimension.

⁴ Theoretical dimension; measured in lb/in.

⁵ See pages 126-127 for How to Order.

Stock Items in carbon steel and 17-7 PH/C stainless steel.

Smalley Part Number ^{1,2,5}	Operates in Bore Diameter	Clears Shaft Diameter	Load (N)	Work Height	Free Height ³	Number of Waves	Number of Turns	Thickness	Radial Wall	Spring Rate ⁴
CM06-L1*	6	4	6	.61	1.52	2.5	3	.13	.51	6.59
CM06-L2*	6	4	6	.81	2.03	2.5	4	.13	.51	4.92
CM06-L3*	6	4	6	1.02	2.54	2.5	5	.13	.51	3.95
CM06-L4*	6	4	6	1.22	3.05	2.5	6	.13	.51	3.28
CM06-L5*	6	4	6	1.42	3.56	2.5	7	.13	.51	2.80
CM06-L6*	6	4	6	1.63	4.06	2.5	8	.13	.51	2.47
CM06-L7*	6	4	6	1.83	4.57	2.5	9	.13	.51	2.19
CM06-L8*	6	4	6	2.24	5.59	2.5	11	.13	.51	1.79
CM06-L9*	6	4	6	2.64	6.60	2.5	13	.13	.51	1.52
CM06-M1*	6	4	12	.74	1.52	2.5	3	.15	.61	15.38
CM06-M2	6	4	12	.97	2.03	2.5	4	.15	.61	11.32
CM06-M3*	6	4	12	1.22	2.54	2.5	5	.15	.61	9.09
CM06-M4*	6	4	12	1.47	3.05	2.5	6	.15	.61	7.59
CM06-M5*	6	4	12	1.70	3.56	2.5	7	.15	.61	6.45
CM06-M6*	6	4	12	1.96	4.06	2.5	8	.15	.61	5.71
CM06-M7*	6	4	12	2.18	4.57	2.5	9	.15	.61	5.02
CM06-M8*	6	4	12	2.69	5.59	2.5	11	.15	.61	4.14
CM06-M9*	6	4	12	3.18	6.60	2.5	13	.15	.61	3.51
CM08-L1	8	5	15	1.70	2.82	2.5	3	.20	.81	13.39
CM08-L2	8	5	15	2.39	3.76	2.5	4	.20	.81	10.95
CM08-L3	8	5	15	2.74	4.70	2.5	5	.20	.81	7.65
CM08-L4	8	5	15	3.56	5.64	2.5	6	.20	.81	7.21
CM08-L5	8	5	15	4.01	6.58	2.5	7	.20	.81	5.84
CM08-L6	8	5	15	4.57	7.52	2.5	8	.20	.81	5.08
CM08-L7	8	5	15	5.26	8.46	2.5	9	.20	.81	4.69
CM08-L8	8	5	15	6.35	10.34	2.5	11	.20	.81	3.76
CM08-L9	8	5	15	7.37	12.22	2.5	13	.20	.81	3.09
CM08-M1	8	5	30	1.78	2.82	2.5	3	.25	.81	28.85
CM08-M2	8	5	30	2.54	3.76	2.5	4	.25	.81	24.59
CM08-M3	8	5	30	3.05	4.70	2.5	5	.25	.81	18.18
CM08-M4	8	5	30	3.81	5.64	2.5	6	.25	.81	16.39
CM08-M5	8	5	30	4.32	6.58	2.5	7	.25	.81	13.27
CM08-M6	8	5	30	4.95	7.52	2.5	8	.25	.81	11.67
CM08-M7	8	5	30	5.59	8.46	2.5	9	.25	.81	10.45
CM08-M8	8	5	30	6.86	10.34	2.5	11	.25	.81	8.62
CM08-M9	8	5	30	7.87	12.22	2.5	13	.25	.81	6.90
CM10-L1	10	7	18	1.91	3.96	2.5	3	.20	.81	8.78
CM10-L2	10	7	18	2.54	5.28	2.5	4	.20	.81	6.57
CM10-L3	10	7	18	3.15	6.60	2.5	5	.20	.81	5.22
CM10-L4	10	7	18	3.78	7.92	2.5	6	.20	.81	4.35
CM10-L5	10	7	18	4.42	9.25	2.5	7	.20	.81	3.73
CM10-L6	10	7	18	5.05	10.57	2.5	8	.20	.81	3.26
CM10-L7	10	7	18	5.69	11.89	2.5	9	.20	.81	2.90
CM10-L8	10	7	18	6.32	13.21	2.5	10	.20	.81	2.61
CM10-L9	10	7	18	6.96	14.53	2.5	11	.20	.81	2.38
CM10-M1	10	7	35	2.03	3.96	2.5	3	.28	.81	18.13
CM10-M2	10	7	35	2.79	5.28	2.5	4	.28	.81	14.06
CM10-M3	10	7	35	3.56	6.60	2.5	5	.28	.81	11.51
CM10-M4	10	7	35	4.32	7.92	2.5	6	.28	.81	9.72
CM10-M5	10	7	35	5.08	9.25	2.5	7	.28	.81	8.39
CM10-M6	10	7	35	5.84	10.57	2.5	8	.28	.81	7.40
CM10-M7	10	7	35	6.60	11.89	2.5	9	.28	.81	6.62
CM10-M8	10	7	35	7.37	13.21	2.5	10	.28	.81	5.99
CM10-M9	10	7	35	8.13	14.53	2.5	11	.28	.81	5.47
CM12-L1	12	9	20	1.47	4.34	2.5	3	.20	1.02	6.97
CM12-L2	12	9	20	1.98	5.79	2.5	4	.20	1.02	5.25
CM12-L3	12	9	20	2.46	7.24	2.5	5	.20	1.02	4.18
CM12-L4	12	9	20	2.95	8.69	2.5	6	.20	1.02	3.48
CM12-L5	12	9	20	3.45	10.13	2.5	7	.20	1.02	2.99
CM12-L6	12	9	20	3.94	11.58	2.5	8	.20	1.02	2.62
CM12-L7	12	9	20	4.45	13.03	2.5	9	.20	1.02	2.33
CM12-L8	12	9	20	4.93	14.48	2.5	10	.20	1.02	2.09
CM12-L9	12	9	20	5.44	15.93	2.5	11	.20	1.02	1.91

¹ Use "CM" prefix for plain ends. Use "CMS" prefix for squared-shim ends.

* Not available with shim ends

² Add suffix "-S17" for 17-7 stainless steel.

³ Reference dimension.

⁴ Theoretical dimension; measured in N/mm.

⁵ See pages 126-127 for How to Order.

Manufactured in USA



Product Dimensions

All dimensions in millimeters unless otherwise specified.

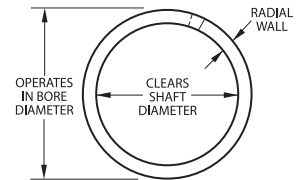

Plain Ends

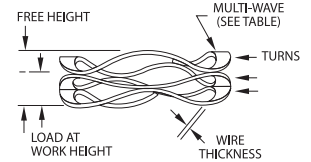

Shim Ends

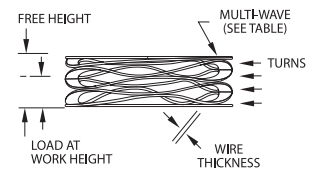

Order Options

CM030-L1

End options:

Plain ends CM
Squared-shim ends CMS

Material option:

Carbon Steel (blank)
Stainless Steel -S17

CM/CMS Series Metric Crest-To-Crest® Springs



Stock Items in carbon steel and 17-7 PH/C stainless steel.

Smalley Part Number ^{1,2,5}	Operates in Bore Diameter	Clears Shaft Diameter	Load (N)	Work Height	Free Height ³	Number of Waves	Number of Turns	Thickness	Radial Wall	Spring Rate ⁴
CM12-M1	12	8.5	40	2.36	4.34	2.5	3	.28	1.17	20.20
CM12-M2	12	8.5	40	3.18	5.79	2.5	4	.28	1.17	15.33
CM12-M3	12	8.5	40	3.96	7.24	2.5	5	.28	1.17	12.20
CM12-M4	12	8.5	40	4.75	8.69	2.5	6	.28	1.17	10.15
CM12-M5	12	8.5	40	5.54	10.13	2.5	7	.28	1.17	8.71
CM12-M6	12	8.5	40	6.32	11.58	2.5	8	.28	1.17	7.60
CM12-M7	12	8.5	40	7.11	13.03	2.5	9	.28	1.17	6.76
CM12-M8	12	8.5	40	7.92	14.48	2.5	10	.28	1.17	6.10
CM12-M9	12	8.5	40	8.71	15.93	2.5	11	.28	1.17	5.54
CM12-H1	12	8.5	60	1.98	4.34	2.5	3	.30	1.14	25.42
CM12-H2	12	8.5	60	2.64	5.79	2.5	4	.30	1.14	19.05
CM12-H3	12	8.5	60	3.30	7.24	2.5	5	.30	1.14	15.23
CM12-H4	12	8.5	60	3.99	8.69	2.5	6	.30	1.14	12.77
CM12-H5	12	8.5	60	4.65	10.13	2.5	7	.30	1.14	10.95
CM12-H6	12	8.5	60	5.31	11.58	2.5	8	.30	1.14	9.57
CM12-H7	12	8.5	60	5.97	13.03	2.5	9	.30	1.14	8.50
CM12-H8	12	8.5	60	6.63	14.48	2.5	10	.30	1.14	7.64
CM12-H9	12	8.5	60	7.29	15.93	2.5	11	.30	1.14	6.94
CM14-L1	14	10	22	2.18	4.95	2.5	3	.23	1.47	7.94
CM14-L2	14	10	22	2.95	6.60	2.5	4	.23	1.47	6.03
CM14-L3	14	10	22	3.71	8.26	2.5	5	.23	1.47	4.84
CM14-L4	14	10	22	4.52	9.91	2.5	6	.23	1.47	4.08
CM14-L5	14	10	22	5.33	11.56	2.5	7	.23	1.47	3.53
CM14-L6	14	10	22	6.17	13.21	2.5	8	.23	1.47	3.13
CM14-L7	14	10	22	7.01	14.86	2.5	9	.23	1.47	2.80
CM14-L8	14	10	22	7.85	16.51	2.5	10	.23	1.47	2.54
CM14-L9	14	10	22	8.71	18.16	2.5	11	.23	1.47	2.33
CM14-M1	14	10	50	2.18	4.95	2.5	3	.30	1.52	18.05
CM14-M2	14	10	50	2.95	6.60	2.5	4	.30	1.52	13.70
CM14-M3	14	10	50	3.71	8.26	2.5	5	.30	1.52	10.99
CM14-M4	14	10	50	4.52	9.91	2.5	6	.30	1.52	9.28
CM14-M5	14	10	50	5.33	11.56	2.5	7	.30	1.52	8.03
CM14-M6	14	10	50	6.17	13.21	2.5	8	.30	1.52	7.10
CM14-M7	14	10	50	7.01	14.86	2.5	9	.30	1.52	6.37
CM14-M8	14	10	50	7.85	16.51	2.5	10	.30	1.52	5.77
CM14-M9	14	10	50	8.71	18.16	2.5	11	.30	1.52	5.29
CM14-H1	14	9	80	3.15	4.95	2.5	3	.38	1.52	44.44
CM14-H2	14	9	80	4.19	6.60	2.5	4	.38	1.52	33.20
CM14-H3	14	9	80	5.26	8.26	2.5	5	.38	1.52	26.67
CM14-H4	14	9	80	6.30	9.91	2.5	6	.38	1.52	22.16
CM14-H5	14	9	80	7.34	11.56	2.5	7	.38	1.52	18.96
CM14-H6	14	9	80	8.41	13.21	2.5	8	.38	1.52	16.67
CM14-H7	14	9	80	9.45	14.86	2.5	9	.38	1.52	14.79
CM14-H8	14	9	80	10.49	16.51	2.5	10	.38	1.52	13.29
CM14-H9	14	9	80	11.56	18.16	2.5	11	.38	1.52	12.12
CM15-L1	15	11	25	2.57	5.18	2.5	3	.25	1.47	9.58
CM15-L2	15	11	25	3.43	6.91	2.5	4	.25	1.47	7.18
CM15-L3	15	11	25	4.27	8.64	2.5	5	.25	1.47	5.72
CM15-L4	15	11	25	5.13	10.36	2.5	6	.25	1.47	4.78
CM15-L5	15	11	25	5.99	12.09	2.5	7	.25	1.47	4.10
CM15-L6	15	11	25	6.83	13.82	2.5	8	.25	1.47	3.58
CM15-L7	15	11	25	7.70	15.54	2.5	9	.25	1.47	3.19
CM15-L8	15	11	25	8.53	17.27	2.5	10	.25	1.47	2.86
CM15-L9	15	11	25	9.40	19.00	2.5	11	.25	1.47	2.60
CM15-M1	15	10	50	3.43	5.18	3.5	3	.23	1.47	28.57
CM15-M2	15	10	50	4.57	6.91	3.5	4	.23	1.47	21.37
CM15-M3	15	10	50	5.72	8.64	3.5	5	.23	1.47	17.12
CM15-M4	15	10	50	6.86	10.36	3.5	6	.23	1.47	14.29
CM15-M5	15	10	50	8.00	12.09	3.5	7	.23	1.47	12.22
CM15-M6	15	10	50	9.14	13.82	3.5	8	.23	1.47	10.68
CM15-M7	15	10	50	10.29	15.54	3.5	9	.23	1.47	9.52
CM15-M8	15	10	50	11.43	17.27	3.5	10	.23	1.47	8.56
CM15-M9	15	10	50	12.57	19.00	3.5	11	.23	1.47	7.78

Product Dimensions

All dimensions in millimeters unless otherwise specified.

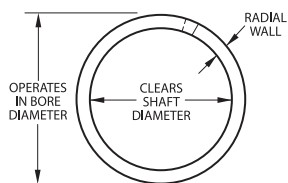

Plain Ends

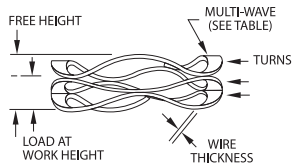

Shim Ends

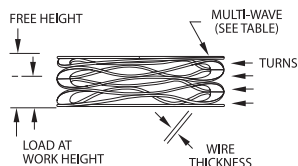

Order Options

CM 030-L1

End options:

Plain ends CM
 Squared-shim ends CMS

Material option:

Carbon Steel (blank)
 Stainless Steel -S17

¹ Use "CM" prefix for plain ends. Use "CMS" prefix for squared-shim ends.

² Add suffix "-S17" for 17-7 stainless steel.

³ Reference dimension.

⁴ Theoretical dimension; measured in N/mm.

⁵ See pages 126-127 for How to Order.

Stock Items in carbon steel and 17-7 PH/C stainless steel.

Smalley Part Number ^{1,2,5}	Operates in Bore Diameter	Clears Shaft Diameter	Load (N)	Work Height	Free Height ³	Number of Waves	Number of Turns	Thickness	Radial Wall	Spring Rate ⁴
CM15-H1	15	10	80	3.20	5.18	3.5	3	.25	1.47	40.40
CM15-H2	15	10	80	4.19	6.91	3.5	4	.25	1.47	29.41
CM15-H3	15	10	80	5.23	8.64	3.5	5	.25	1.47	23.46
CM15-H4	15	10	80	6.27	10.36	3.5	6	.25	1.47	19.56
CM15-H5	15	10	80	7.32	12.09	3.5	7	.25	1.47	16.77
CM15-H6	15	10	80	8.36	13.82	3.5	8	.25	1.47	14.65
CM15-H7	15	10	80	9.40	15.54	3.5	9	.25	1.47	13.03
CM15-H8	15	10	80	10.46	17.27	3.5	10	.25	1.47	11.75
CM15-H9	15	10	80	11.51	19.00	3.5	11	.25	1.47	10.68
CM16-L1	16	11	25	2.11	5.41	2.5	3	.25	1.47	7.58
CM16-L2	16	11	25	2.79	7.21	2.5	4	.25	1.47	5.66
CM16-L3	16	11	25	3.51	9.02	2.5	5	.25	1.47	4.54
CM16-L4	16	11	25	4.19	10.82	2.5	6	.25	1.47	3.77
CM16-L5	16	11	25	4.90	12.62	2.5	7	.25	1.47	3.24
CM16-L6	16	11	25	6.30	16.23	2.5	9	.25	1.47	2.52
CM16-L7	16	11	25	7.70	19.84	2.5	11	.25	1.47	2.06
CM16-L8	16	11	25	9.09	23.44	2.5	13	.25	1.47	1.74
CM16-M1	16	11	55	3.63	5.41	3.5	3	.25	1.47	30.90
CM16-M2	16	11	55	4.83	7.21	3.5	4	.25	1.47	23.11
CM16-M3	16	11	55	6.05	9.02	3.5	5	.25	1.47	18.52
CM16-M4	16	11	55	7.24	10.82	3.5	6	.25	1.47	15.36
CM16-M5	16	11	55	8.46	12.62	3.5	7	.25	1.47	13.22
CM16-M6	16	11	55	10.87	16.23	3.5	9	.25	1.47	10.26
CM16-M7	16	11	55	13.28	19.84	3.5	11	.25	1.47	8.38
CM16-M8	16	11	55	15.70	23.44	3.5	13	.25	1.47	7.11
CM16-H1	16	11	90	3.30	5.41	3.5	3	.30	1.52	42.65
CM16-H2	16	11	90	4.57	7.21	3.5	4	.30	1.52	34.09
CM16-H3	16	11	90	5.59	9.02	3.5	5	.30	1.52	26.24
CM16-H4	16	11	90	6.86	10.82	3.5	6	.30	1.52	22.73
CM16-H5	16	11	90	7.87	12.62	3.5	7	.30	1.52	18.95
CM16-H6	16	11	90	10.16	16.23	3.5	9	.30	1.52	14.83
CM16-H7	16	11	90	12.45	19.84	3.5	11	.30	1.52	12.18
CM16-H8	16	11	90	14.73	23.44	3.5	13	.30	1.52	10.33
CM18-L1	18	13	30	3.63	5.72	3.5	3	.20	1.80	14.35
CM18-L2	18	13	30	4.75	7.62	3.5	4	.20	1.80	10.45
CM18-L3	18	13	30	5.94	9.53	3.5	5	.20	1.80	8.36
CM18-L4	18	13	30	7.14	11.43	3.5	6	.20	1.80	6.99
CM18-L5	18	13	30	8.31	13.34	3.5	7	.20	1.80	5.96
CM18-L6	18	13	30	10.69	17.15	3.5	9	.20	1.80	4.64
CM18-L7	18	13	30	14.25	22.86	3.5	12	.20	1.80	3.48
CM18-M1	18	13	55	3.68	5.72	3.5	3	.25	1.83	26.96
CM18-M2	18	13	55	4.98	7.62	3.5	4	.25	1.83	20.83
CM18-M3	18	13	55	6.22	9.53	3.5	5	.25	1.83	16.62
CM18-M4	18	13	55	7.47	11.43	3.5	6	.25	1.83	13.89
CM18-M5	18	13	55	8.74	13.34	3.5	7	.25	1.83	11.96
CM18-M6	18	13	55	11.23	17.15	3.5	9	.25	1.83	9.29
CM18-M7	18	13	55	14.96	22.86	3.5	12	.25	1.83	6.96
CM18-H1	18	13	90	3.84	5.72	3.5	3	.30	1.83	47.87
CM18-H2	18	13	90	5.13	7.62	3.5	4	.30	1.83	36.14
CM18-H3	18	13	90	6.40	9.53	3.5	5	.30	1.83	28.75
CM18-H4	18	13	90	7.70	11.43	3.5	6	.30	1.83	24.13
CM18-H5	18	13	90	8.97	13.34	3.5	7	.30	1.83	20.59
CM18-H6	18	13	90	11.53	17.15	3.5	9	.30	1.83	16.01
CM18-H7	18	13	90	15.37	22.86	3.5	12	.30	1.83	12.02
CM20-L1	20	15	35	2.72	6.32	3.5	3	.20	1.80	9.72
CM20-L2	20	15	35	3.61	8.43	3.5	4	.20	1.80	7.26
CM20-L3	20	15	35	4.52	10.54	3.5	5	.20	1.80	5.81
CM20-L4	20	15	35	5.41	12.65	3.5	6	.20	1.80	4.83
CM20-L5	20	15	35	6.32	14.76	3.5	7	.20	1.80	4.15
CM20-L6	20	15	35	8.13	18.97	3.5	9	.20	1.80	3.23
CM20-L7	20	15	35	10.82	25.30	3.5	12	.20	1.80	2.42
CM20-M1	20	14	70	3.05	6.32	3.5	3	.25	1.98	21.41
CM20-M2	20	14	70	4.06	8.43	3.5	4	.25	1.98	16.02
CM20-M3	20	14	70	5.08	10.54	3.5	5	.25	1.98	12.82

¹ Use "CM" prefix for plain ends. Use "CMS" prefix for squared-shim ends.

² Add suffix "-S17" for 17-7 stainless steel.

³ Reference dimension.

⁴ Theoretical dimension; measured in N/mm.

⁵ See pages 126-127 for How to Order.

Manufactured in USA



Product Dimensions

All dimensions in millimeters unless otherwise specified.

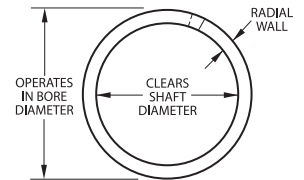

Plain Ends

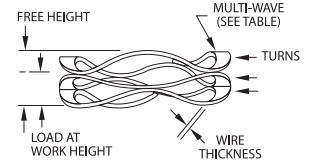

Shim Ends

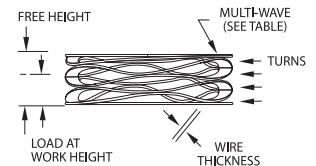

Order Options

CM 030-L1

End options:

Plain ends **CM**
 Squared-shim ends **CMS**

Material option:

Carbon Steel **(blank)**
 Stainless Steel **-S17**

CM/CMS Series Metric Crest-To-Crest® Springs



Stock Items in carbon steel and 17-7 PH/C stainless steel.

Smalley Part Number ^{1,2,5}	Operates in Bore Diameter	Clears Shaft Diameter	Load (N)	Work Height	Free Height ³	Number of Waves	Number of Turns	Thickness	Radial Wall	Spring Rate ⁴
CM20-M4	20	14	70	6.27	12.65	3.5	6	.25	1.98	10.97
CM20-M5	20	14	70	7.32	14.76	3.5	7	.25	1.98	9.41
CM20-M6	20	14	70	9.17	18.97	3.5	9	.25	1.98	7.14
CM20-M7	20	14	70	12.22	25.30	3.5	12	.25	1.98	5.35
CM20-H1	20	14	100	4.24	6.32	3.5	3	.33	2.01	48.08
CM20-H2	20	14	100	5.66	8.43	3.5	4	.33	2.01	36.10
CM20-H3	20	14	100	7.06	10.54	3.5	5	.33	2.01	28.74
CM20-H4	20	14	100	8.48	12.65	3.5	6	.33	2.01	23.98
CM20-H5	20	14	100	9.91	14.76	3.5	7	.33	2.01	20.62
CM20-H6	20	14	100	12.73	18.97	3.5	9	.33	2.01	16.03
CM20-H7	20	14	100	16.97	25.30	3.5	12	.33	2.01	12.00
CM25-L1	25	19	50	2.06	6.63	3.5	3	.25	2.18	10.94
CM25-L2	25	19	50	2.74	8.84	3.5	4	.25	2.18	8.20
CM25-L3	25	19	50	3.43	11.05	3.5	5	.25	2.18	6.56
CM25-L4	25	19	50	4.11	13.26	3.5	6	.25	2.18	5.46
CM25-L5	25	19	50	4.80	15.47	3.5	7	.25	2.18	4.69
CM25-L6	25	19	50	6.20	19.89	3.5	9	.25	2.18	3.65
CM25-L7	25	19	50	8.26	26.52	3.5	12	.25	2.18	2.74
CM25-M1	25	19	80	2.95	6.63	3.5	3	.30	2.39	21.74
CM25-M2	25	19	80	3.94	8.84	3.5	4	.30	2.39	16.33
CM25-M3	25	19	80	4.90	11.05	3.5	5	.30	2.39	13.01
CM25-M4	25	19	80	5.89	13.26	3.5	6	.30	2.39	10.85
CM25-M5	25	19	80	6.88	15.47	3.5	7	.30	2.39	9.31
CM25-M6	25	19	80	8.84	19.89	3.5	9	.30	2.39	7.24
CM25-M7	25	19	80	11.79	26.52	3.5	12	.30	2.39	5.43
CM25-H1	25	19	110	4.04	6.63	3.5	3	.38	2.39	42.47
CM25-H2	25	19	110	5.38	8.84	3.5	4	.38	2.39	31.79
CM25-H3	25	19	110	6.73	11.05	3.5	5	.38	2.39	25.46
CM25-H4	25	19	110	8.08	13.26	3.5	6	.38	2.39	21.24
CM25-H5	25	19	110	9.40	15.47	3.5	7	.38	2.39	18.12
CM25-H6	25	19	110	12.12	19.89	3.5	9	.38	2.39	14.16
CM25-H7	25	19	110	16.15	26.52	3.5	12	.38	2.39	10.61
CM28-L1	28	22	50	3.76	7.24	3.5	3	.30	2.39	14.37
CM28-L2	28	22	50	5.00	9.65	3.5	4	.30	2.39	10.75
CM28-L3	28	22	50	6.27	12.07	3.5	5	.30	2.39	8.62
CM28-L4	28	22	50	7.52	14.48	3.5	6	.30	2.39	7.18
CM28-L5	28	22	50	8.79	16.89	3.5	7	.30	2.39	6.17
CM28-L6	28	22	50	10.03	19.30	3.5	8	.30	2.39	5.39
CM28-L7	28	22	50	11.28	21.72	3.5	9	.30	2.39	4.79
CM28-L8	28	22	50	13.79	26.54	3.5	11	.30	2.39	3.92
CM28-L9	28	22	50	16.31	31.37	3.5	13	.30	2.39	3.32
CM28-M1	28	22	80	4.39	7.24	3.5	3	.38	2.39	28.07
CM28-M2	28	22	80	5.84	9.65	3.5	4	.38	2.39	21.00
CM28-M3	28	22	80	7.32	12.07	3.5	5	.38	2.39	16.84
CM28-M4	28	22	80	8.79	14.48	3.5	6	.38	2.39	14.06
CM28-M5	28	22	80	10.24	16.89	3.5	7	.38	2.39	12.03
CM28-M6	28	22	80	11.71	19.30	3.5	8	.38	2.39	10.54
CM28-M7	28	22	80	13.18	21.72	3.5	9	.38	2.39	9.37
CM28-M8	28	22	80	16.10	26.54	3.5	11	.38	2.39	7.66
CM28-M9	28	22	80	19.02	31.37	3.5	13	.38	2.39	6.48
CM28-H1	28	22	130	4.57	7.24	3.5	3	.46	2.39	48.69
CM28-H2	28	22	130	6.07	9.65	3.5	4	.46	2.39	36.31
CM28-H3	28	22	130	7.59	12.07	3.5	5	.46	2.39	29.02
CM28-H4	28	22	130	9.12	14.48	3.5	6	.46	2.39	24.25
CM28-H5	28	22	130	10.64	16.89	3.5	7	.46	2.39	20.80
CM28-H6	28	22	130	12.17	19.30	3.5	8	.46	2.39	18.23
CM28-H7	28	22	130	13.69	21.72	3.5	9	.46	2.39	16.19
CM28-H8	28	22	130	16.71	26.54	3.5	11	.46	2.39	13.22
CM28-H9	28	22	130	19.76	31.37	3.5	13	.46	2.39	11.20
CM30-L1	30	24	50	3.18	7.62	3.5	3	.30	2.39	11.26
CM30-L2	30	24	50	4.22	10.16	3.5	4	.30	2.39	8.42
CM30-L3	30	24	50	5.28	12.70	3.5	5	.30	2.39	6.74
CM30-L4	30	24	50	6.32	15.24	3.5	6	.30	2.39	5.61
CM30-L5	30	24	50	7.39	17.78	3.5	7	.30	2.39	4.81

Product Dimensions

All dimensions in millimeters unless otherwise specified.

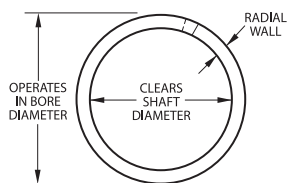

Plain Ends

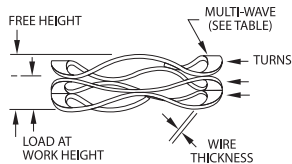

Shim Ends

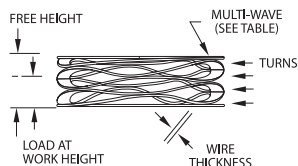

Order Options

CM 030-L1

End options:

Plain ends CM
Squared-shim ends CMS

Material option:

Carbon Steel (blank)
Stainless Steel -S17

¹ Use "CM" prefix for plain ends. Use "CMS" prefix for squared-shim ends.

² Add suffix "-S17" for 17-7 stainless steel.

³ Reference dimension.

⁴ Theoretical dimension; measured in N/mm.

⁵ See pages 126-127 for How to Order.

Stock Items in carbon steel and 17-7 PH/C stainless steel.

Smalley Part Number ^{1,2,5}	Operates in Bore Diameter	Clears Shaft Diameter	Load (N)	Work Height	Free Height ³	Number of Waves	Number of Turns	Thickness	Radial Wall	Spring Rate ⁴
CM30-L6	30	24	50	8.43	20.32	3.5	8	.30	2.39	4.21
CM30-L7	30	24	50	9.50	22.86	3.5	9	.30	2.39	3.74
CM30-L8	30	24	50	11.61	27.94	3.5	11	.30	2.39	3.06
CM30-L9	30	24	50	13.72	33.02	3.5	13	.30	2.39	2.59
CM30-M1	30	24	90	3.51	7.62	3.5	3	.38	2.39	21.90
CM30-M2	30	24	90	4.70	10.16	3.5	4	.38	2.39	16.48
CM30-M3	30	24	90	5.87	12.70	3.5	5	.38	2.39	13.18
CM30-M4	30	24	90	7.04	15.24	3.5	6	.38	2.39	10.98
CM30-M5	30	24	90	8.20	17.78	3.5	7	.38	2.39	9.39
CM30-M6	30	24	90	9.37	20.32	3.5	8	.38	2.39	8.22
CM30-M7	30	24	90	10.54	22.86	3.5	9	.38	2.39	7.31
CM30-M8	30	24	90	12.90	27.94	3.5	11	.38	2.39	5.98
CM30-M9	30	24	90	15.24	33.02	3.5	13	.38	2.39	5.06
CM30-H1	30	24	130	4.19	7.62	3.5	3	.46	2.39	37.90
CM30-H2	30	24	130	5.59	10.16	3.5	4	.46	2.39	28.45
CM30-H3	30	24	130	6.99	12.70	3.5	5	.46	2.39	22.77
CM30-H4	30	24	130	8.38	15.24	3.5	6	.46	2.39	18.95
CM30-H5	30	24	130	9.78	17.78	3.5	7	.46	2.39	16.25
CM30-H6	30	24	130	11.18	20.32	3.5	8	.46	2.39	14.22
CM30-H7	30	24	130	12.57	22.86	3.5	9	.46	2.39	12.63
CM30-H8	30	24	130	15.37	27.94	3.5	11	.46	2.39	10.34
CM30-H9	30	24	130	18.16	33.02	3.5	13	.46	2.39	8.75
CM35-L1	35	27	70	3.94	8.38	3.5	3	.36	3.18	15.77
CM35-L2	35	27	70	5.23	11.18	3.5	4	.36	3.18	11.76
CM35-L3	35	27	70	6.55	13.97	3.5	5	.36	3.18	9.43
CM35-L4	35	27	70	7.87	16.76	3.5	6	.36	3.18	7.87
CM35-L5	35	27	70	9.17	19.56	3.5	7	.36	3.18	6.74
CM35-L6	35	27	70	10.49	22.35	3.5	8	.36	3.18	5.90
CM35-L7	35	27	70	11.81	25.15	3.5	9	.36	3.18	5.25
CM35-L8	35	27	70	14.43	30.73	3.5	11	.36	3.18	4.29
CM35-L9	35	27	70	17.04	36.32	3.5	13	.36	3.18	3.63
CM35-M1	35	27	110	4.14	8.38	3.5	3	.41	3.38	25.94
CM35-M2	35	27	110	5.51	11.18	3.5	4	.41	3.38	19.40
CM35-M3	35	27	110	6.88	13.97	3.5	5	.41	3.38	15.51
CM35-M4	35	27	110	8.26	16.76	3.5	6	.41	3.38	12.94
CM35-M5	35	27	110	9.63	19.56	3.5	7	.41	3.38	11.08
CM35-M6	35	27	110	11.02	22.35	3.5	8	.41	3.38	9.71
CM35-M7	35	27	110	12.40	25.15	3.5	9	.41	3.38	8.63
CM35-M8	35	27	110	15.14	30.73	3.5	11	.41	3.38	7.06
CM35-M9	35	27	110	17.91	36.32	3.5	13	.41	3.38	5.98
CM35-H1	35	27	160	4.04	8.38	3.5	3	.46	3.38	36.87
CM35-H2	35	27	160	5.38	11.18	3.5	4	.46	3.38	27.59
CM35-H3	35	27	160	6.73	13.97	3.5	5	.46	3.38	22.10
CM35-H4	35	27	160	8.08	16.76	3.5	6	.46	3.38	18.43
CM35-H5	35	27	160	9.42	19.56	3.5	7	.46	3.38	15.78
CM35-H6	35	27	160	10.77	22.35	3.5	8	.46	3.38	13.82
CM35-H7	35	27	160	12.12	25.15	3.5	9	.46	3.38	12.28
CM35-H8	35	27	160	14.81	30.73	3.5	11	.46	3.38	10.05
CM35-H9	35	27	160	17.50	36.32	3.5	13	.46	3.38	8.50
CM40-L1	40	30	100	2.90	9.14	3.5	3	.41	3.38	16.03
CM40-L2	40	30	100	3.86	12.19	3.5	4	.41	3.38	12.00
CM40-L3	40	30	100	4.80	15.24	3.5	5	.41	3.38	9.58
CM40-L4	40	30	100	5.77	18.29	3.5	6	.41	3.38	7.99
CM40-L5	40	30	100	6.73	21.34	3.5	7	.41	3.38	6.84
CM40-L6	40	30	100	7.70	24.38	3.5	8	.41	3.38	6.00
CM40-L7	40	30	100	8.66	27.43	3.5	9	.41	3.38	5.33
CM40-L8	40	30	100	10.59	33.53	3.5	11	.41	3.38	4.36
CM40-L9	40	30	100	12.52	39.62	3.5	13	.41	3.38	3.69
CM40-M1	40	30	150	5.44	9.14	3.5	3	.53	3.63	40.54
CM40-M2	40	30	150	7.24	12.19	3.5	4	.53	3.63	30.30
CM40-M3	40	30	150	9.04	15.24	3.5	5	.53	3.63	24.19
CM40-M4	40	30	150	10.85	18.29	3.5	6	.53	3.63	20.16
CM40-M5	40	30	150	12.65	21.34	3.5	7	.53	3.63	17.26

¹ Use "CM" prefix for plain ends. Use "CMS" prefix for squared-shim ends.

² Add suffix "-S17" for 17-7 stainless steel.

³ Reference dimension.

⁴ Theoretical dimension; measured in N/mm.

⁵ See pages 126-127 for How to Order.

Manufactured in USA



Product Dimensions

All dimensions in millimeters unless otherwise specified.

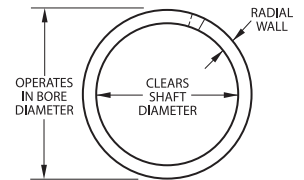

Plain Ends

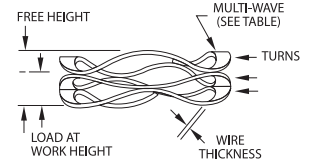

Shim Ends

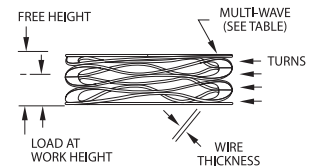

Order Options

CM 030-L1

End options:
 Plain ends CM
 Squared-shim ends CMS

Material option:
 Carbon Steel (blank)
 Stainless Steel -S17

CM/CMS Series Metric Crest-To-Crest® Springs



Stock Items in carbon steel and 17-7 PH/C stainless steel.

Smalley Part Number ^{1,2,5}	Operates in Bore Diameter	Clears Shaft Diameter	Load (N)	Work Height	Free Height ³	Number of Waves	Number of Turns	Thickness	Radial Wall	Spring Rate ⁴
CM40-M6	40	30	150	14.48	24.38	3.5	8	.53	3.63	15.15
CM40-M7	40	30	150	16.28	27.43	3.5	9	.53	3.63	13.45
CM40-M8	40	30	150	19.89	33.53	3.5	11	.53	3.63	11.00
CM40-M9	40	30	150	23.50	39.62	3.5	13	.53	3.63	9.31
CM40-H1	40	30	300	5.66	9.14	4.5	3	.46	3.38	86.21
CM40-H2	40	30	300	7.54	12.19	4.5	4	.46	3.38	64.52
CM40-H3	40	30	300	9.42	15.24	4.5	5	.46	3.38	51.55
CM40-H4	40	30	300	11.33	18.29	4.5	6	.46	3.38	43.10
CM40-H5	40	30	300	13.21	21.34	4.5	7	.46	3.38	36.90
CM40-H6	40	30	300	15.09	24.38	4.5	8	.46	3.38	32.29
CM40-H7	40	30	300	16.97	27.43	4.5	9	.46	3.38	28.68
CM40-H8	40	30	300	20.75	33.53	4.5	11	.46	3.38	23.47
CM40-H9	40	30	300	24.54	39.62	4.5	13	.46	3.38	19.89
CM45-L1	45	35	110	3.38	9.91	3.5	3	.46	3.63	16.85
CM45-L2	45	35	110	4.52	13.21	3.5	4	.46	3.63	12.66
CM45-L3	45	35	110	5.64	16.51	3.5	5	.46	3.63	10.12
CM45-L4	45	35	110	6.76	19.81	3.5	6	.46	3.63	8.43
CM45-L5	45	35	110	7.90	23.11	3.5	7	.46	3.63	7.23
CM45-L6	45	35	110	9.02	26.42	3.5	8	.46	3.63	6.32
CM45-L7	45	35	110	10.16	29.72	3.5	9	.46	3.63	5.62
CM45-L8	45	35	110	12.40	36.32	3.5	11	.46	3.63	4.60
CM45-L9	45	35	110	14.66	42.93	3.5	13	.46	3.63	3.89
CM45-M1	45	35	225	5.33	9.91	4.5	3	.46	3.63	49.13
CM45-M2	45	35	225	6.99	13.21	4.5	4	.46	3.63	36.17
CM45-M3	45	35	225	9.14	16.51	4.5	5	.46	3.63	30.53
CM45-M4	45	35	225	10.80	19.81	4.5	6	.46	3.63	24.97
CM45-M5	45	35	225	12.70	23.11	4.5	7	.46	3.63	21.61
CM45-M6	45	35	225	14.48	26.42	4.5	8	.46	3.63	18.84
CM45-M7	45	35	225	16.26	29.72	4.5	9	.46	3.63	16.72
CM45-M8	45	35	225	19.81	36.32	4.5	11	.46	3.63	13.63
CM45-M9	45	35	225	23.37	42.93	4.5	13	.46	3.63	11.50
CM45-H1	45	35	400	6.43	9.91	4.5	3	.61	3.76	114.94
CM45-H2	45	35	400	8.38	13.21	4.5	4	.61	3.76	82.82
CM45-H3	45	35	400	11.20	16.51	4.5	5	.61	3.76	75.33
CM45-H4	45	35	400	12.95	19.81	4.5	6	.61	3.76	58.31
CM45-H5	45	35	400	15.37	23.11	4.5	7	.61	3.76	51.68
CM45-H6	45	35	400	17.27	26.42	4.5	8	.61	3.76	43.72
CM45-H7	45	35	400	19.68	29.72	4.5	9	.61	3.76	39.88
CM45-H8	45	35	400	24.26	36.32	4.5	11	.61	3.76	33.17
CM45-H9	45	35	400	28.45	42.93	4.5	13	.61	3.76	27.62
CM50-L1	50	40	110	4.83	10.29	3.5	3	.53	3.63	20.15
CM50-L2	50	40	110	6.10	13.72	3.5	4	.53	3.63	14.44
CM50-L3	50	40	110	7.87	17.15	3.5	5	.53	3.63	11.85
CM50-L4	50	40	110	9.40	20.57	3.5	6	.53	3.63	9.85
CM50-L5	50	40	110	11.30	24.00	3.5	7	.53	3.63	8.66
CM50-L6	50	40	110	12.70	27.43	3.5	8	.53	3.63	7.47
CM50-L7	50	40	110	14.99	30.86	3.5	9	.53	3.63	6.93
CM50-L8	50	40	110	18.16	37.72	3.5	11	.53	3.63	5.62
CM50-L9	50	40	110	21.34	44.58	3.5	13	.53	3.63	4.73
CM50-L10	50	40	110	24.64	51.44	3.5	15	.53	3.63	4.10
CM50-M1	50	40	225	4.62	10.29	4.5	3	.46	3.63	39.68
CM50-M2	50	40	225	6.35	13.72	4.5	4	.46	3.63	30.53
CM50-M3	50	40	225	7.49	17.15	4.5	5	.46	3.63	23.29
CM50-M4	50	40	225	8.89	20.57	4.5	6	.46	3.63	19.26
CM50-M5	50	40	225	10.54	24.00	4.5	7	.46	3.63	16.72
CM50-M6	50	40	225	11.89	27.43	4.5	8	.46	3.63	14.48
CM50-M7	50	40	225	13.59	30.86	4.5	9	.46	3.63	13.03
CM50-M8	50	40	225	16.71	37.72	4.5	11	.46	3.63	10.71
CM50-M9	50	40	225	19.61	44.58	4.5	13	.46	3.63	9.01
CM50-M10	50	40	225	22.48	51.44	4.5	15	.46	3.63	7.77
CM50-H1	50	40	400	5.92	10.29	4.5	3	.61	3.76	91.53
CM50-H2	50	40	400	7.80	13.72	4.5	4	.61	3.76	67.57
CM50-H3	50	40	400	10.16	17.15	4.5	5	.61	3.76	57.22
CM50-H4	50	40	400	11.79	20.57	4.5	6	.61	3.76	45.56
CM50-H5	50	40	400	14.15	24.00	4.5	7	.61	3.76	40.61
CM50-H6	50	40	400	15.62	27.43	4.5	8	.61	3.76	33.87

Product Dimensions

All dimensions in millimeters unless otherwise specified.

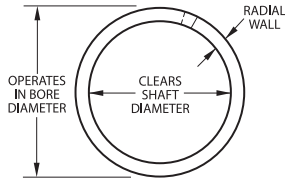

Plain Ends

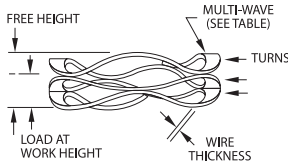

Shim Ends

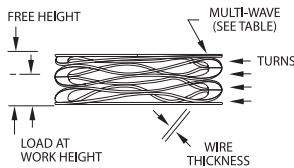

Order Options

CM 030-L1

End options:

Plain ends CM
 Squared-shim ends CMS

Material option:

Carbon Steel (blank)
 Stainless Steel -S17

¹ Use "CM" prefix for plain ends. Use "CMS" prefix for squared-shim ends.

² Add suffix "-S17" for 17-7 stainless steel.

³ Reference dimension.

⁴ Theoretical dimension; measured in N/mm.

⁵ See pages 126-127 for How to Order.

Stock Items in carbon steel and 17-7 PH/C stainless steel.

Smalley Part Number ^{1,2,5}	Operates in Bore Diameter	Clears Shaft Diameter	Load (N)	Work Height	Free Height ³	Number of Waves	Number of Turns	Thickness	Radial Wall	Spring Rate ⁴
CM50-H7	50	40	400	17.91	30.86	4.5	9	.61	3.76	30.89
CM50-H8	50	40	400	21.54	37.72	4.5	11	.61	3.76	24.72
CM50-H9	50	40	400	25.65	44.58	4.5	13	.61	3.76	21.13
CM50-H10	50	40	400	29.21	51.44	4.5	15	.61	3.76	17.99
CM55-L1	55	45	125	5.59	11.05	3.5	3	.61	3.76	22.89
CM55-L2	55	45	125	7.72	14.73	3.5	4	.61	3.76	17.83
CM55-L3	55	45	125	9.68	18.41	3.5	5	.61	3.76	14.30
CM55-L4	55	45	125	11.48	22.10	3.5	6	.61	3.76	11.77
CM55-L5	55	45	125	13.92	25.78	3.5	7	.61	3.76	10.54
CM55-L6	55	45	125	15.52	29.46	3.5	8	.61	3.76	8.97
CM55-L7	55	45	125	18.41	33.15	3.5	9	.61	3.76	8.49
CM55-L8	55	45	125	21.67	40.51	3.5	11	.61	3.76	6.63
CM55-L9	55	45	125	25.65	47.88	3.5	13	.61	3.76	5.62
CM55-L10	55	45	125	29.77	55.25	3.5	15	.61	3.76	4.91
CM55-M1	55	45	250	3.10	11.05	4.5	3	.46	3.63	31.45
CM55-M2	55	45	250	4.11	14.73	4.5	4	.46	3.63	23.54
CM55-M3	55	45	250	5.16	18.41	4.5	5	.46	3.63	18.85
CM55-M4	55	45	250	6.20	22.10	4.5	6	.46	3.63	15.72
CM55-M5	55	45	250	7.21	25.78	4.5	7	.46	3.63	13.46
CM55-M6	55	45	250	8.26	29.46	4.5	8	.46	3.63	11.79
CM55-M7	55	45	250	9.27	33.15	4.5	9	.46	3.63	10.47
CM55-M8	55	45	250	11.33	40.51	4.5	11	.46	3.63	8.57
CM55-M9	55	45	250	13.41	47.88	4.5	13	.46	3.63	7.25
CM55-M10	55	45	250	15.47	55.25	4.5	15	.46	3.63	6.28
CM55-H1	55	45	400	5.31	11.05	4.5	3	.61	3.76	69.69
CM55-H2	55	45	400	7.24	14.73	4.5	4	.61	3.76	53.40
CM55-H3	55	45	400	9.09	18.41	4.5	5	.61	3.76	42.87
CM55-H4	55	45	400	10.64	22.10	4.5	6	.61	3.76	34.90
CM55-H5	55	45	400	12.24	25.78	4.5	7	.61	3.76	29.54
CM55-H6	55	45	400	14.10	29.46	4.5	8	.61	3.76	26.04
CM55-H7	55	45	400	15.82	33.15	4.5	9	.61	3.76	23.08
CM55-H8	55	45	400	19.30	40.51	4.5	11	.61	3.76	18.86
CM55-H9	55	45	400	23.11	47.88	4.5	13	.61	3.76	16.15
CM55-H10	55	45	400	26.54	55.25	4.5	15	.61	3.76	13.93
CM60-L1	60	50	135	5.59	11.43	4.5	3	.46	3.63	23.12
CM60-L2	60	50	135	7.47	15.24	4.5	4	.46	3.63	17.37
CM60-L3	60	50	135	9.32	19.05	4.5	5	.46	3.63	13.87
CM60-L4	60	50	135	11.20	22.86	4.5	6	.46	3.63	11.58
CM60-L5	60	50	135	13.06	26.67	4.5	7	.46	3.63	9.92
CM60-L6	60	50	135	14.94	30.48	4.5	8	.46	3.63	8.69
CM60-L7	60	50	135	16.79	34.29	4.5	9	.46	3.63	7.71
CM60-L8	60	50	135	20.52	41.91	4.5	11	.46	3.63	6.31
CM60-L9	60	50	135	24.26	49.53	4.5	13	.46	3.63	5.34
CM60-L10	60	50	135	27.99	57.15	4.5	15	.46	3.63	4.63
CM60-M1	60	50	275	6.65	11.43	4.5	3	.61	3.76	57.53
CM60-M2	60	50	275	8.86	15.24	4.5	4	.61	3.76	43.10
CM60-M3	60	50	275	11.07	19.05	4.5	5	.61	3.76	34.46
CM60-M4	60	50	275	13.28	22.86	4.5	6	.61	3.76	28.71
CM60-M5	60	50	275	15.49	26.67	4.5	7	.61	3.76	24.60
CM60-M6	60	50	275	17.70	30.48	4.5	8	.61	3.76	21.52
CM60-M7	60	50	275	19.94	34.29	4.5	9	.61	3.76	19.16
CM60-M8	60	50	275	24.36	41.91	4.5	11	.61	3.76	15.67
CM60-M9	60	50	275	28.78	49.53	4.5	13	.61	3.76	13.25
CM60-M10	60	50	275	33.22	57.15	4.5	15	.61	3.76	11.49
CM60-H1	60	50	450	7.75	11.43	4.5	3	.76	4.01	122.28
CM60-H2	60	50	450	10.31	15.24	4.5	4	.76	4.01	91.28
CM60-H3	60	50	450	12.90	19.05	4.5	5	.76	4.01	73.17
CM60-H4	60	50	450	15.47	22.86	4.5	6	.76	4.01	60.89
CM60-H5	60	50	450	18.06	26.67	4.5	7	.76	4.01	52.26
CM60-H6	60	50	450	20.62	30.48	4.5	8	.76	4.01	45.64
CM60-H7	60	50	450	23.22	34.29	4.5	9	.76	4.01	40.65
CM60-H8	60	50	450	28.37	41.91	4.5	11	.76	4.01	33.23
CM60-H9	60	50	450	33.53	49.53	4.5	13	.76	4.01	28.13
CM60-H10	60	50	450	38.68	57.15	4.5	15	.76	4.01	24.36

¹ Use "CM" prefix for plain ends. Use "CMS" prefix for squared-shim ends.

² Add suffix "-S17" for 17-7 stainless steel.

³ Reference dimension.

⁴ Theoretical dimension; measured in N/mm.

⁵ See pages 126-127 for How to Order.



Product Dimensions

All dimensions in millimeters unless otherwise specified.

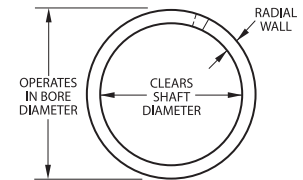

Plain Ends

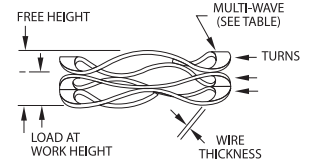

Shim Ends

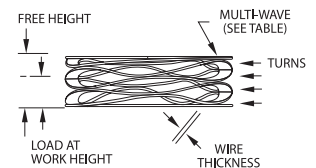

Order Options

CM 030-L1

End options:

Plain ends CM
Squared-shim ends CMS

Material option:

Carbon Steel (blank)
Stainless Steel -S17

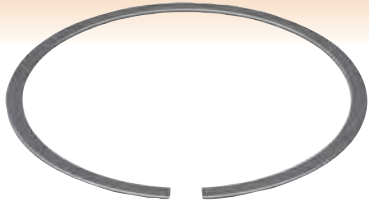

Smalley Shims are commonly used in conjunction with wave springs where a back-up plate is needed for housings made of softer metals like aluminum or bronze, and for packings made of leather, neoprene or similar materials. Shims can function as spacers to change wave spring operating heights. Adding or subtracting shims is an excellent method of adjusting load on a wave spring. Using a shim spacer can also control tolerance buildups.

Stock Items in carbon steel and 17-7 PH/C stainless steel. However, Smalley can make them to order in nearly any size or material.

Smalley Part Number ^{1,3}	Outside Diameter	Thickness	Radial Wall	Part Weight ²	Smalley Part Number ^{1,3}	Outside Diameter	Thickness	Radial Wall	Part Weight ²
SSRS-0075	.750	.024	.093	1.31	SSRS-0550	5.500	.030	.233	32.77
SSRS-0087	.875	.024	.093	1.55	SSRS-0562	5.625	.030	.233	33.54
SSRS-0100	1.000	.024	.103	1.97	SSRS-0575	5.750	.030	.233	34.32
SSRS-0112	1.125	.024	.138	2.91	SSRS-0587	5.875	.030	.233	35.10
SSRS-0125	1.250	.024	.138	3.28	SSRS-0600	6.000	.030	.233	35.88
SSRS-0137	1.375	.024	.138	3.65	SSRS-0612	6.125	.030	.233	36.66
SSRS-0150	1.500	.024	.150	4.33	SSRS-0625	6.250	.030	.233	37.43
SSRS-0162	1.625	.024	.150	4.73	SSRS-0637	6.375	.030	.233	38.21
SSRS-0175	1.750	.024	.150	5.13	SSRS-0650	6.500	.030	.233	38.99
SSRS-0187	1.875	.024	.150	5.53	SSRS-0675	6.750	.030	.233	40.54
SSRS-0200	2.000	.024	.150	5.93	SSRS-0700	7.000	.032	.375	70.76
SSRS-0212	2.125	.024	.150	6.33	SSRS-0725	7.250	.032	.375	73.43
SSRS-0225	2.250	.024	.150	6.73	SSRS-0750	7.500	.032	.375	76.10
SSRS-0237	2.375	.024	.178	8.35	SSRS-0775	7.750	.032	.375	78.77
SSRS-0250	2.500	.024	.178	8.83	SSRS-0800	8.000	.032	.375	81.44
SSRS-0262	2.625	.024	.178	9.30	SSRS-0825	8.250	.032	.375	84.11
SSRS-0275	2.750	.030	.188	12.86	SSRS-0850	8.500	.032	.375	86.78
SSRS-0287	2.875	.030	.188	13.49	SSRS-0875	8.750	.032	.375	89.45
SSRS-0300	3.000	.030	.188	14.12	SSRS-0900	9.000	.032	.375	92.12
SSRS-0312	3.125	.030	.188	14.74	SSRS-0950	9.500	.032	.375	97.46
SSRS-0325	3.250	.030	.233	18.77	SSRS-1000	10.000	.032	.375	102.80
SSRS-0337	3.375	.030	.233	19.55	SSRS-1050	10.500	.032	.375	108.14
SSRS-0350	3.500	.030	.233	20.32	SSRS-1100	11.000	.032	.375	113.48
SSRS-0362	3.625	.030	.233	21.10	SSRS-1150	11.500	.032	.375	118.82
SSRS-0375	3.750	.030	.233	21.88	SSRS-1200	12.000	.032	.375	124.16
SSRS-0387	3.875	.030	.233	22.66	SSRS-1250	12.500	.032	.375	129.50
SSRS-0400	4.000	.030	.233	23.44	SSRS-1300	13.000	.032	.375	134.84
SSRS-0412	4.125	.030	.233	24.21	SSRS-1350	13.500	.032	.375	140.18
SSRS-0425	4.250	.030	.233	24.99	SSRS-1400	14.000	.032	.375	145.52
SSRS-0437	4.375	.030	.233	25.77	SSRS-1450	14.500	.032	.375	150.86
SSRS-0450	4.500	.030	.233	26.55	SSRS-1500	15.000	.032	.375	156.20
SSRS-0462	4.625	.030	.233	27.32	SSRS-1550	15.500	.032	.375	161.54
SSRS-0475	4.750	.030	.233	28.10	SSRS-1600	16.000	.032	.375	166.88
SSRS-0487	4.875	.030	.233	28.88					
SSRS-0500	5.000	.030	.233	29.66					
SSRS-0512	5.125	.030	.233	30.43					
SSRS-0525	5.250	.030	.233	31.21					
SSRS-0537	5.375	.030	.233	31.99					

Product Dimensions

All dimensions in inches unless otherwise specified.

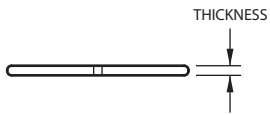
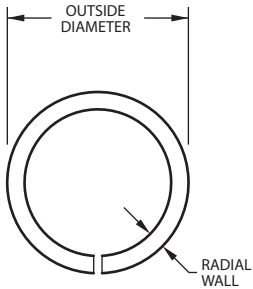

¹ Add suffix "-S17" for 17-7 stainless steel.

² Lbs. per 1000.

³ See pages 126-127 for How to Order.



Spring Tester

Spring Tester

Springs are inspected for load, deflection, free height and spring rate with this compression spring tester, designed and built by Smalley. Main components of the tester are described below.

The accuracy in checking spring load/deflection characteristics is dependent on the accuracy and precision of the testing device itself. The concept of accurate compression testing relies greatly on the following tester features:

1. Upper and lower plates must remain parallel throughout the test. Generally, the distance between upper and lower plates must be within .002 at any point, from zero to full load.
2. Upper and lower plates must be rigid in that they should not misalign with the spring positioned at any point on the lower plate (note that placing a spring off-center induces a moment, which tends to both tip the plates and cause frictional drag.)
3. The load system must be free of friction, which can cause hysteresis in the load values obtained in the test.
4. Testing surfaces of both the lower and upper plates must be smooth and free of scratches, cracks or other physical imperfections.

Fatigue Tester

Fatigue cycling is often a consideration when designing compression springs. Testing provides a more accurate prediction of actual cycle life and is recommended whenever cycle life is critical or when calculations show little margin over the cycle requirement.

Ideally, springs should be cycle tested in the actual assembly. Where this is not feasible, Smalley offers testing on high speed cycle machinery. The cycle test machinery can be adjusted to various work heights and stroke lengths to simulate the actual application.

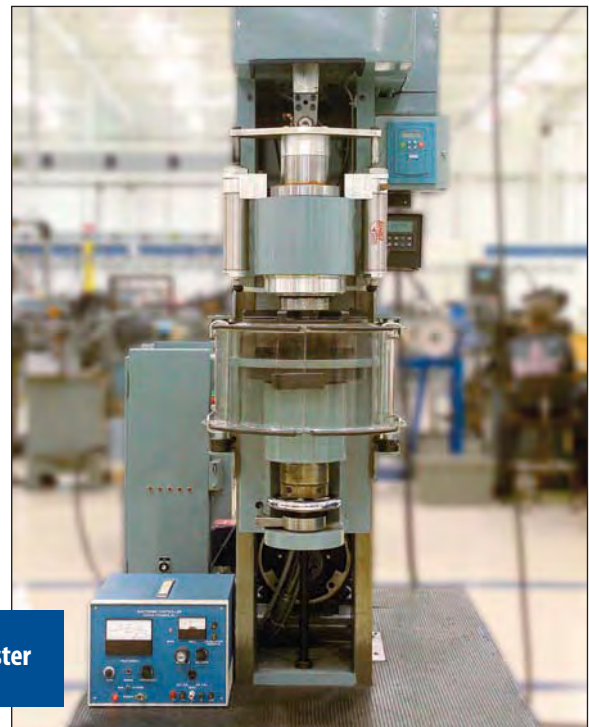

Fatigue Tester

Ring Introduction

Advantages of Spirolox® Retaining Rings

Spirolox Retaining Rings have No Ears to Interfere in your assembly! Spirolox Rings are manufactured by coiling the ring from flat wire. This unique process produces a retaining ring that has no protruding ears or burrs to interfere with your assembly. Because coiling produces a retaining ring with no scrap, the Spirolox Ring can be economically produced in carbon steel, stainless steel, coppers, and many other alloys.

Smalley offers over 6,000 standard parts, which are readily available in both carbon and stainless steel. If you require special designs, take advantage of Smalley's No-Tooling-Cost process; a process perfect for large runs, prototypes and midstream design changes. Whatever your application, Smalley has the cost-effective and innovative design solution.



Spirolox Retaining Rings offer many advantages over stamped retaining rings

- No gap - 360° retaining surface
- No protruding ears to interfere with mating components (uniform cross-section)
- Economically produced in stainless steel because the coiling process produces no scrap
- **No-Tooling-Charge** on special designs
- Easy installation and removal

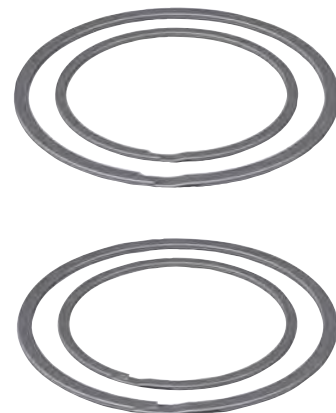

Other Ring Types & Special Designs



Constant Section Rings

Another popular choice of retaining ring configurations is the well known Constant Section Ring. Produced by edgewinding with no special tooling charges, Constant Section Rings have been specified for many years in the automotive and heavy equipment industries as a standard choice of engineers.

Smalley has hundreds of standard Constant Section Rings in stock, in carbon steel and stainless steel and in both inch and metric sizes. Special or custom designs can be produced quickly and economically utilizing Smalley's precision No-Tooling-Cost manufacturing process.

Constant Section Rings can withstand high forces and impact loads and are easily installed and removed from their internal or external groove for field servicing your product.



WAVERING®

The WaveRing is a spiral retaining ring with an axial wave form. It acts like a standard retaining ring with the additional feature of compressibility. It compensates for the overall length tolerance of stacked components, while still acting as a retaining ring. Once assembled the WaveRing will reduce looseness and vibration in the assembly.

Designed to fit into a groove, the WaveRing applies pressure in two directions: against the groove wall and against the assembly components. Single, double or multiple turns in the WaveRing are possible as well as a choice of materials, including our standard 17-7 ph stainless and carbon steel.



Special Rings

A major segment of Smalley manufacturing is in "special" or prototype retaining rings. Common Smalley specials include balanced, multi-turn (4,5,6 turns and more) and special ends in diameters from .200 in – 120 in (5 mm – 3,000 mm) and larger. Smalley engineers are on hand to help you design a ring specific to your application. Because there are no tooling costs, no job is too big or too little. Prototypes can be quickly and economically produced to test a design; in days, not weeks.

Retaining Ring Selection Guide

1

STEP 1: Do you need to meet any specifications?
YES **NO**

Specification	Smalley Series
Military MIL- DTL-27426/3WH
Military MIL- DTL-27426/1WS
Military MIL- DTL-27426/4WHM
Military MIL- DTL-27426/2WSM
Aerospace AS4299, AS3217, AS3219WH
Aerospace AS4299, AS3218, AS3219WS
Aerospace AS4299, AS3215, AS3219WHM
Aerospace AS4299, AS3216, AS3219WSM
Metric Aerospace MA 4017EH
Metric Aerospace MA 4016ES



2

STEP 2: Do you need to match an alternative ring groove?
YES **NO**

Manufacturer	Smalley Series
Truarc N5000 & 5008WHM
Truarc 5100 & 5108WSM
Eaton NANWHT
Eaton XANWST
Eaton I-NWHM
Eaton E-NWSM
Industrial RR 3000 & 4000WHM
Industrial RR 3100 & 4100WSM
Anderton N1300WHM
Anderton N1400WSM
Anderton D1300DNH
Anderton D1400DNS
European Specification DIN 472DNH
European Specification DIN 471DNS



3

STEP 3A: Choose by the Thrust Capacity needed OR see step 3B

Standard Units (inches)			
Series	Load ¹	Housing	Shaft
Light Duty	4100	VH	VS
Medium Duty	4950	WH	WS
Medium Heavy Duty	7070	WHT	WST
Heavy Duty	8340	WHM	WSM
Constant Section Rings	8341	FHE	FSE
WaveRing	—	WHW	WSW

Metric Units (mm)			
Series	Load ¹	Housing	Shaft
Light Duty	18.03	VHM	VSM
DIN Series 2	36.55	DNH	DNS
Aerospace Series	38.96	EH	ES
Constant Section Rings	36.53	FH	FS

¹ Representative example shows the load capacity (lb) for a 2" ring.

¹ Representative example shows the load capacity (kN) for a 50 mm ring.

² Manufactured to DIN groove specifications.

STEP 3B: Still not sure?

Use Smalley's most popular series, Medium Duty WH (internal) or WS (external).

Ask for a free sample.

Relative proportions of rings in grooves

A cross-section of each Spirolox Retaining Ring configuration is illustrated, comparing groove and ring sections in the same diameter bore or shaft. The heavier retaining ring cross-sections are in deeper and wider grooves, to provide significantly greater thrust capacity.

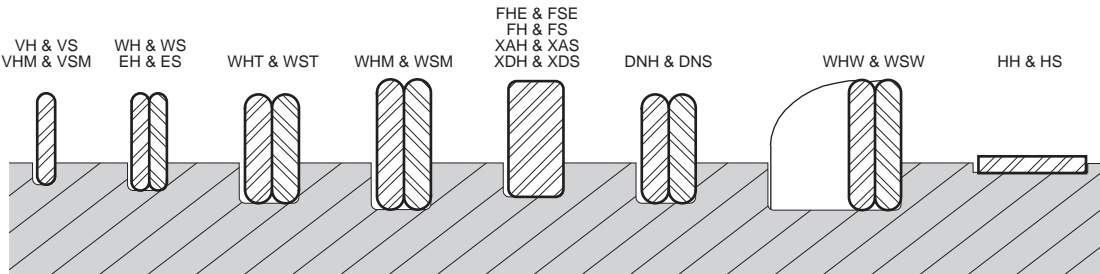

Ring Types

Spirolox Retaining Rings—Single Turn (1-Turn)

VH & VS — Light Duty, inch
VHM & VSM — Light Duty, metric

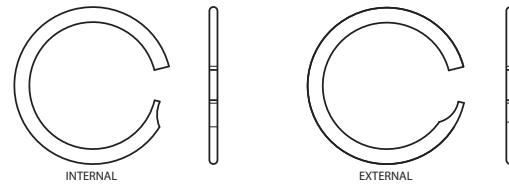

Spirolox Retaining Rings—2-Turn

WH & WS — Medium Duty, inch
WHT & WST — Medium Heavy Duty, inch
WHM & WSM — Heavy Duty, inch
EH & ES — Medium Duty, Metric Aerospace
DNH & DNS — Heavy Duty DIN, metric

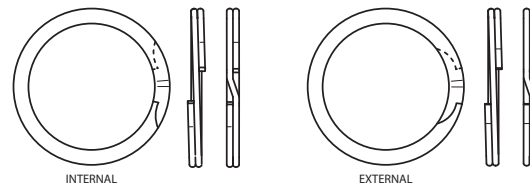

Constant Section Rings

FHE & FSE — Heavy Duty, inch
FH & FS — Heavy Duty, metric
*XAH & XAS — Eaton Style, inch
*XDH & XDS — Eaton Style, inch

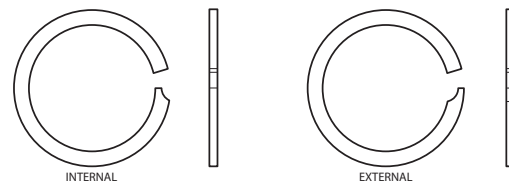

WaveRings

WHW & WSW — inch

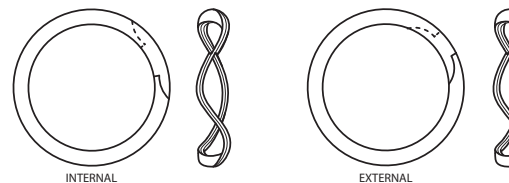

Hoopster Rings

HH & HS — inch

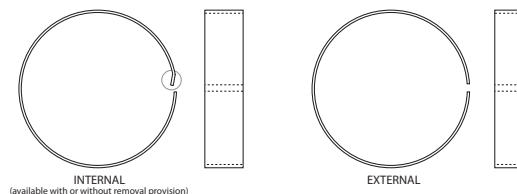

*End configurations vary by size; see page 120 for Constant Section Ring end configurations.

Selection Guide

Interchange Listing

Smalley Retaining Rings are interchangeable with both inch and metric retaining ring grooves. Smalley offers free samples of all stock retaining rings to test in your application.

Cross reference a standard stamped ring or snap ring to find the appropriate Smalley Retaining Ring to fit your application.

SMALLEY®	SPIROLOX® SERIES	MILITARY MIL-DTL-27426	AEROSPACE AS3219	METRIC AEROSPACE MA 4035	EUROPEAN SPECIFICATION DIN	WALDES TRUARC	EATON	INDUSTRIAL RETAINING RING	OTHER RINGS	ANDERTON
VH	UR	---	---	---						
VS	US	---	---	---						
WH	RR	/3	AS4299 AS3217	---						
WS	RS	/1	AS4299 AS3218	---						
WHT	RRT	---	---	---	---	---	NAN	---	UHB	---
WST	RST	---	---	---	---	---	XAN	---	USC	---
WHM	RRN	/4	AS4299 AS3215	---	---	N5000 5008	IN	3000 4000	HO HOI UHO	N1300
WSM	RSN	/2	AS4299 AS3216	---	---	5100 5108	EN	3100 4100	SH SHI USH	N1400
DNH	---	---	---	---	DIN 472	---	---	---	DHO	D1300
DNS	---	---	---	---	DIN 471	---	---	---	DSH	D1400
EH	---	---	---	MA 4017	---	---	---	---	---	---
ES	---	---	---	MA 4016	---	---	---	---	---	---
FH	---	---	---	---	DIN 472	---	---	---	DHO	D1300
FS	---	---	---	---	DIN 471	---	---	---	DSH	D1400
XAH	---	---	---	---	---	---	NAN	---	UHB	---
XAS	---	---	---	---	---	---	XAN	---	USC	---
XDH	---	---	---	---	---	---	ND	---	HN	---
XDS	---	---	---	---	---	---	XD	---	SNL	---
XNH	---	---	---	---	---	---	IN	---	UHO	---
XNS	---	---	---	---	---	---	EN	---	USH	---

Groove Interchange Only

Use a Smalley Retaining Ring to fit into the same groove of these stamped Retaining Rings (circlips).



A. Rubber Boot

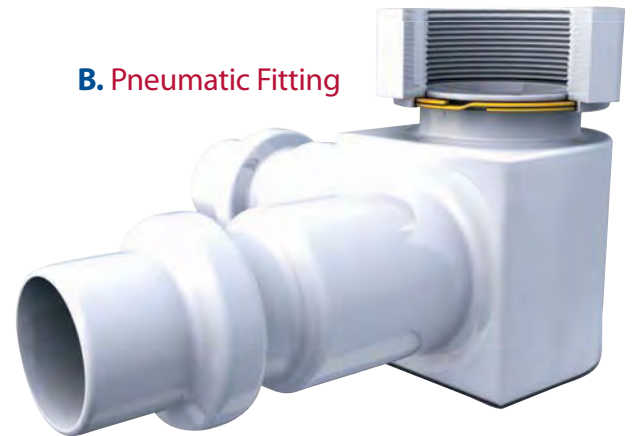

B. Pneumatic Fitting



C. Conduit Connector



D. Gear Bracket



E. Ratchet Wrench



F. Cylinder Housing

A. Rubber Boot

A 2-Turn Spirolox Retaining Ring clamps the rubber boot onto the groove making for a nearly perfect seal when the boot is filled with grease. The ring has been deburred so it will not tear into the rubber.

B. Pneumatic Fitting

An economical (without removal notches or offset) 2-Turn Spirolox Retaining Ring creates an ID/OD lock, permitting the 360° rotation of the nut. This permanent assembly is commonly used to hold two components together.

C. Conduit Connector

In this unique application, a Dished Retaining Ring was designed with sharp edges, to bite into the conduit it holds in place. The clamping force of the ring to the conduit (not shown) is achieved by screwing the nut. This decreases the ring's diameter as it advances in a tapered bore.

D. Gear Bracket

The worm gear shaft is held in place and preloaded using a 2-Turn Smalley WaveRing. The WaveRing fits an internal groove and the waveform in the ring allows the gear/shaft to float axially as the gear rotates.

E. Ratchet Wrench

This Single-Turn (it is actually 1½ turns) External Retaining Ring retains the internal mechanical components of the ratchet wrench. The additional ½ turn provides that little extra strength needed to prevent the ring from dislodging when the wrench is dropped.

F. Cylinder Housing

The Hoopster Retaining Ring in this application allows for a shallow groove in the cylinder housing without compromising the ability to have high forces applied to the Hoopster. Because the cylinder is thin, a normal retaining ring groove could not be used.

Ring Applications



G. Bike Lock



I. Gear Assembly



K. Pneumatic Clutch

H. Pressure Gauge

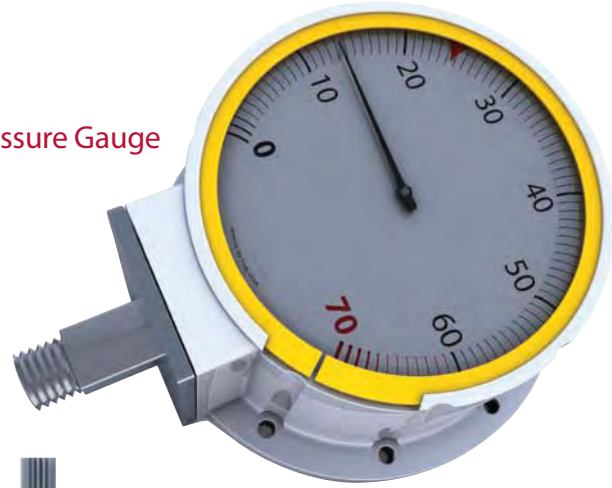

J. Actuator Valve

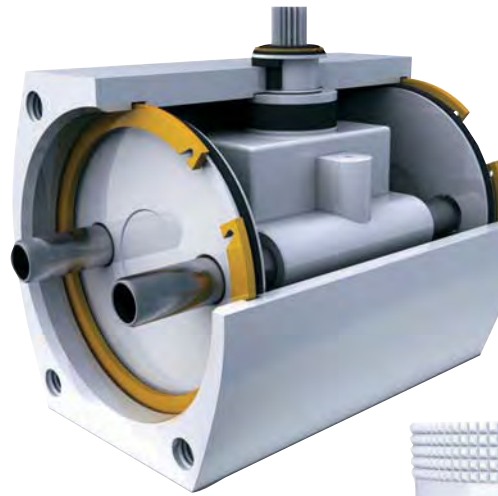

L. Hose Fitting



G. Bike Lock

Tamper-proof ring holds the lock assembly within its housing. The ring is considered tamper-proof because of reversed removal notches. Also, having a heavy cross-section makes the ring nearly impossible to remove.

H. Pressure Gauge

A retaining ring designed in a shallow groove exerts very light pressure on the glass lens in this pressure gauge. This single-turn retaining ring design provides the optimum load without breaking the glass.

I. Gear Assembly

External 2-Turn retaining ring prevents the pinion shafts from spinning when the gears are rotating. The Spirolox ring snaps securely on the groove and the ring's radial wall is designed to extend radially outward, clearing the four flat pinion shaft pins by .020".

J. Actuator Valve

High thrust capacity was needed and a constant section ring was selected to absorb the occasional shock loading of the pistons.

K. Pneumatic Clutch

The internal components of this clutch are held in the housing using a heavy-duty constant section ring. Field servicing was often necessary and the snap ring was the ideal solution to the design requirement.

L. Hose Fitting

To keep the cap on the fitting, a single-turn retaining ring is located in a shallow internal groove. The wall thickness of the cap is small, so the ring was designed with square corners to operate in a very shallow groove.

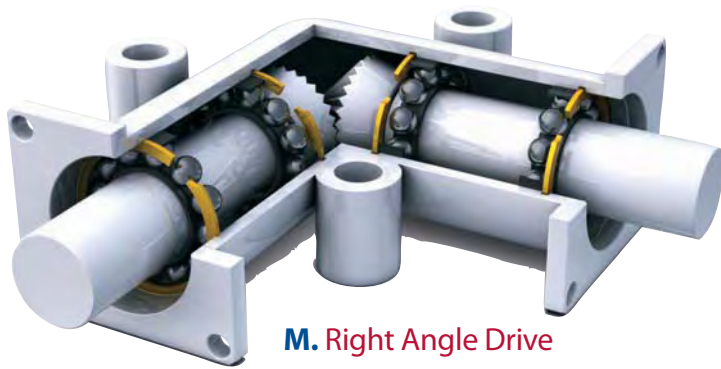

M. Right Angle Drive

N. Air Vent



O. Pulley



P. Belt Pulley



Q. ID/OD Lock



R. Hip Replacement

M. Right Angle Drive

Constant section rings secure the bearing assembly by providing removable shoulders in the bore. This simplifies the design of the gear box and replaces costly flanged end plates.

N. Air Vent

Single-turn, light-duty retaining ring fits tightly in the internal groove of a plastic air vent. Ring ends are dimensioned close together, providing nearly complete 360° ring support.

O. Pulley

2-Turn retaining rings provide 360° side walls as sides of the timing belt pulley. Design eliminates costly pressed-on stamped side walls. For belt replacement one ring can be easily removed.

P. Belt Pulley

Three hold down screws and a 2-Turn Spirolox Ring form a bi-directional shoulder. The shaft is inserted through the pulley and the retaining ring rests on the pulley face securing the shaft in one direction. Movement is prevented in the other direction with the three screws clamping down on the ring.

Q. ID/OD Lock

Single-turn retaining ring operates in an internal and external groove at the same time, commonly referred to as an ID/OD Lock. In this application, the ring fits tight on the body (shaft) groove and extends radially into the nut (housing). This allows the nut to spin freely but not come off the body.

R. Hip Replacement

A titanium Spirolox Retaining Ring is used in this hip replacement application to secure the shell and the liner together to form the socket of the new hip. Smalley's manufacturing process allows for the economical production of special alloy products.

Assembly Methods

Manual Installation

Manual installation on an individual or low production basis is accomplished as follows:

- Separate the ring coils and insert one end of the ring into the groove.
- Wind the ring by pressing down around the circumference until the entire ring is inserted into the groove.

Housing:

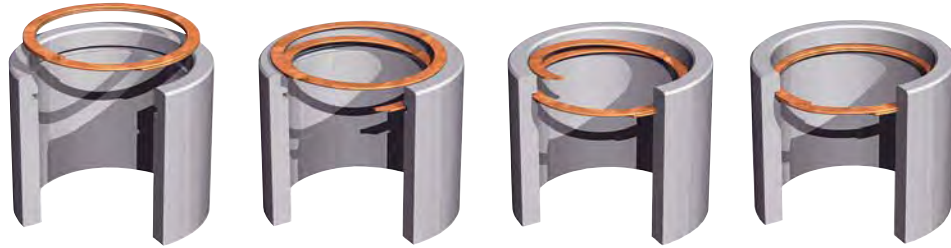

Shaft:



Semi-Automated and Automated Installation

For higher speed and automated assembly operations, simple tooling or assembly fixtures can be designed. External installation on a shaft can be accomplished with a plunger and tapered plug. The plug, angled at approximately 6 degrees, is centered over the shaft end. A loose fitting plunger pushes the ring into position over the tapered plug. An arbor press or air cylinder is commonly used to automate this assembly operation.

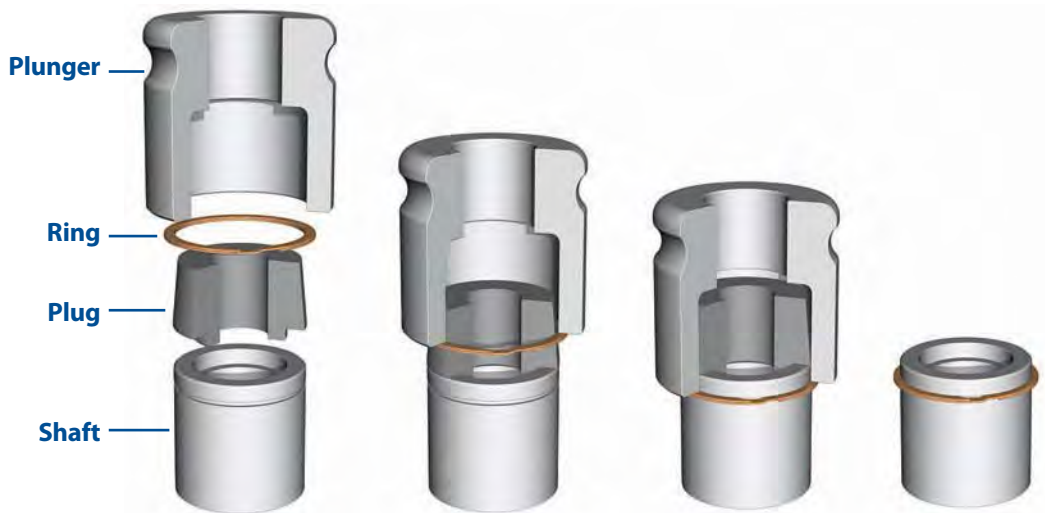

Internal retaining ring installation is accomplished in a similar manner. A tapered bore, which acts as a ring contracting guide, and a plunger pushes the retaining ring into position. Tooling for ring installation should have hardened working surfaces to minimize wear.

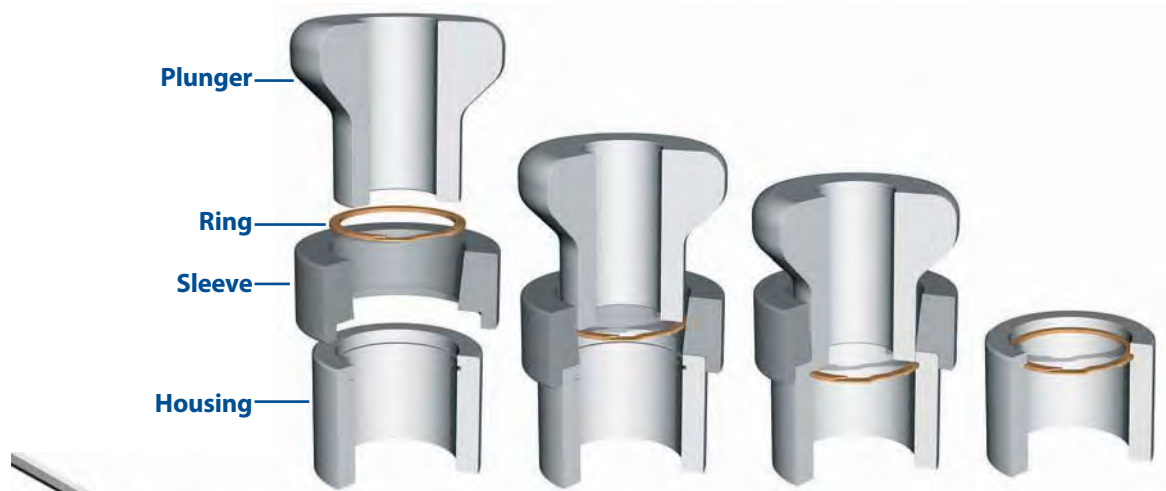

Using Screwdriver



Using Dental Pick

Removal

Smalley Retaining Rings are supplied standard with removal notches to enable easy extraction from a groove. The notch is provided to form a small gap between the ring end and the shaft or housing, permitting a blunt object to be inserted at the end of the ring to pry the free end out radially and up.

- Insert a screwdriver or dental pick behind the removal notch.
- Use the tool to pry out the first end of the ring.
- Manually spiral the ring around until it is free from the groove.

Smalley Tooling

Smalley's Spirolox Retaining Ring Removal Tool, part number RT-107, fits between the layers of a multiple turn retaining ring in order to access the removal notch. The end of the tool bit is slotted for the tip of the notch end to pass through. Once inserted, the ring end may be pulled out radially and up.

Visit www.smalley.com/retaining_rings/installation_and_removal.asp for more information about installation and removal.



Stock Items available in carbon steel and 302 and 316 stainless steel.

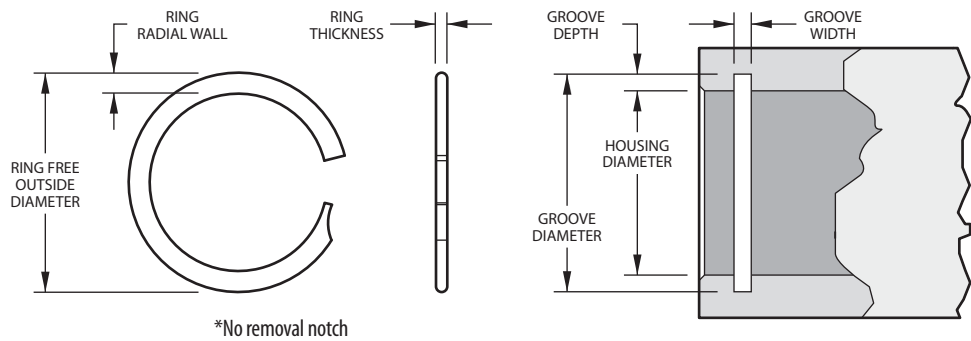
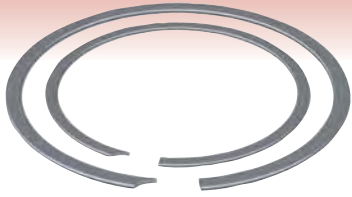

Product Dimensions All dimensions are in inches unless otherwise specified.

Smalley Part Number ^{1,4}	Housing Diameter	Ring			Groove		Thrust Capacity	
		Outside Diameter	Radial Wall	Thickness	Diameter	Width	Groove Yield (lb) ²	Ring Shear (lb) ³
VH-25*	.250	.264	.020	.012	.262	.015	106	481
VH-31*	.312	.329	.025	.015	.326	.018	154	750
VH-37*	.375	.398	.030	.015	.395	.018	265	901
VH-43	.437	.466	.030	.015	.463	.018	402	1,050
VH-50	.500	.531	.045	.018	.528	.022	500	1,300
VH-56	.562	.593	.045	.018	.590	.022	560	1,460
VH-62	.625	.656	.045	.018	.653	.022	620	1,630
VH-68	.687	.719	.045	.018	.715	.022	680	1,790
VH-75	.750	.783	.045	.018	.779	.022	800	1,950
VH-81	.812	.862	.065	.021	.854	.026	1,210	2,460
VH-87	.875	.926	.065	.021	.917	.026	1,300	2,660
VH-93	.937	.989	.065	.021	.979	.026	1,390	2,840
VH-100	1.000	1.052	.065	.021	1.042	.026	1,480	3,040
VH-106	1.062	1.117	.088	.025	1.106	.031	1,650	3,500
VH-112	1.125	1.180	.088	.025	1.169	.031	1,750	3,710
VH-118	1.187	1.242	.088	.025	1.231	.031	1,850	3,920
VH-125	1.250	1.307	.088	.025	1.294	.031	1,940	4,120
VH-131	1.312	1.369	.088	.025	1.356	.031	2,040	4,330
VH-137	1.375	1.433	.088	.025	1.419	.031	2,140	4,540
VH-143	1.437	1.496	.088	.025	1.481	.031	2,240	4,740
VH-150	1.500	1.559	.088	.025	1.544	.031	2,330	4,950
VH-156	1.562	1.637	.118	.031	1.619	.039	3,200	6,390
VH-162	1.625	1.701	.118	.031	1.682	.039	3,330	6,650
VH-168	1.687	1.763	.118	.031	1.744	.039	3,460	6,900
VH-175	1.750	1.827	.118	.031	1.807	.039	3,590	7,160
VH-181	1.812	1.890	.118	.031	1.869	.039	3,710	7,410
VH-187	1.875	1.953	.118	.031	1.932	.039	3,840	7,670
VH-193	1.937	2.016	.118	.031	1.994	.039	3,970	7,920
VH-200	2.000	2.079	.118	.031	2.057	.039	4,100	8,180
VH-206	2.062	2.162	.158	.031	2.138	.039	5,540	8,430
VH-212	2.125	2.226	.158	.031	2.201	.039	5,710	8,690
VH-218	2.187	2.289	.158	.031	2.263	.039	5,870	8,950
VH-225	2.250	2.352	.158	.031	2.326	.039	6,040	9,200
VH-231	2.312	2.415	.158	.031	2.388	.039	6,210	9,460
VH-237	2.375	2.478	.158	.031	2.451	.039	6,380	9,720
VH-243	2.437	2.541	.158	.031	2.513	.039	6,550	9,970
VH-250	2.500	2.605	.158	.031	2.576	.039	6,720	10,230
VH-256	2.562	2.667	.158	.031	2.638	.039	6,880	10,480
VH-262	2.625	2.731	.158	.031	2.701	.039	7,050	10,740
VH-268	2.687	2.794	.158	.031	2.763	.039	7,220	10,990
VH-275	2.750	2.857	.158	.031	2.826	.039	7,390	11,250
VH-281	2.812	2.920	.158	.031	2.888	.039	7,550	11,500
VH-287	2.875	2.983	.158	.031	2.951	.039	7,720	11,760
VH-293	2.937	3.046	.158	.031	3.013	.039	7,890	12,010
VH-300	3.000	3.110	.158	.031	3.076	.039	8,060	12,270

¹ Add suffix "-S02" for 302 stainless steel, "-S16" for 316 stainless steel.

² Based on a groove material yield strength of 45,000 psi and a safety factor of 2.

³ Based on a safety factor of 3.

⁴ See pages 126-127 for How to Order.

Smalley Part Number ^{1,4}	Housing Diameter	Ring			Groove		Thrust Capacity	
		Outside Diameter	Radial Wall	Thickness	Diameter	Width	Groove Yield (lb) ²	Ring Shear (lb) ³
VH-306	3.062	3.188	.188	.039	3.154	.044	9,960	15,760
VH-312	3.125	3.251	.188	.039	3.217	.044	10,160	16,080
VH-318	3.187	3.314	.188	.039	3.279	.044	10,360	16,400
VH-325	3.250	3.377	.188	.039	3.342	.044	10,570	16,720
VH-331	3.312	3.440	.188	.039	3.404	.044	10,770	17,040
VH-337	3.375	3.504	.188	.039	3.467	.044	10,970	17,370
VH-343	3.437	3.566	.188	.039	3.529	.044	11,180	17,690
VH-350	3.500	3.630	.188	.039	3.592	.044	11,380	18,010
VH-356	3.562	3.692	.188	.039	3.654	.044	11,580	18,330
VH-362	3.625	3.756	.188	.039	3.717	.044	11,790	18,650
VH-368	3.687	3.819	.188	.039	3.779	.044	11,990	18,970
VH-375	3.750	3.882	.188	.039	3.842	.044	12,190	19,300
VH-381	3.812	3.945	.188	.039	3.904	.044	12,400	19,620
VH-387	3.875	4.009	.188	.039	3.967	.044	12,600	19,940
VH-393	3.937	4.071	.188	.039	4.029	.044	12,800	20,260
VH-400	4.000	4.135	.188	.039	4.092	.044	13,010	20,580
VH-412	4.125	4.279	.225	.046	4.235	.052	16,040	23,850
VH-425	4.250	4.405	.225	.046	4.360	.052	16,520	24,570
VH-437	4.375	4.531	.225	.046	4.485	.052	17,010	25,290
VH-450	4.500	4.658	.225	.046	4.610	.052	17,500	26,010
VH-462	4.625	4.784	.225	.046	4.735	.052	17,980	26,740
VH-475	4.750	4.910	.225	.046	4.860	.052	18,470	27,460
VH-487	4.875	5.036	.225	.046	4.985	.052	18,950	28,180
VH-500	5.000	5.163	.225	.046	5.110	.052	19,440	28,900
VH-525	5.250	5.435	.225	.061	5.381	.067	24,490	40,240
VH-550	5.500	5.694	.225	.061	5.638	.067	26,830	42,160
VH-575	5.750	5.953	.225	.061	5.894	.067	29,260	44,080
VH-600	6.000	6.212	.265	.061	6.150	.067	31,810	45,990
VH-625	6.250	6.470	.265	.061	6.406	.067	34,460	47,910
VH-650	6.500	6.730	.265	.061	6.663	.067	37,680	49,830
VH-675	6.750	6.988	.265	.061	6.919	.067	40,560	51,740
VH-700	7.000	7.247	.265	.061	7.175	.067	43,540	53,660
VH-725	7.250	7.505	.265	.061	7.431	.067	46,640	55,580
VH-750	7.500	7.765	.265	.061	7.688	.067	49,830	57,490
VH-775	7.750	8.023	.300	.061	7.944	.067	53,140	59,410
VH-800	8.000	8.282	.300	.061	8.200	.067	56,550	61,320
VH-825	8.250	8.541	.300	.061	8.456	.067	60,070	63,240
VH-850	8.500	8.800	.300	.061	8.713	.067	64,290	65,160
VH-875	8.750	9.059	.345	.076	8.969	.082	68,040	83,570
VH-900	9.000	9.317	.345	.076	9.225	.082	71,890	85,950
VH-925	9.250	9.576	.345	.076	9.481	.082	75,850	88,340
VH-950	9.500	9.835	.345	.076	9.738	.082	79,910	90,730
VH-975	9.750	10.094	.345	.076	9.994	.082	84,080	93,120
VH-1000	10.000	10.353	.345	.076	10.250	.082	88,360	95,500

¹ Add suffix "-S02" for 302 stainless steel, "-S16" for 316 stainless steel.

² Based on a groove material yield strength of 45,000 psi and a safety factor of 2.

³ Based on a safety factor of 3.

⁴ See pages 126-127 for How to Order.

Stock Items available in carbon steel and 302 and 316 stainless steel.

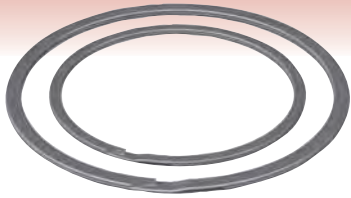

**AS3217, AS4299
MIL-DTL-27426/3**

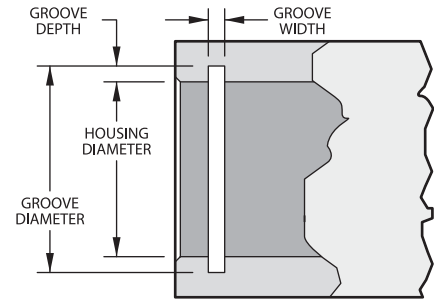
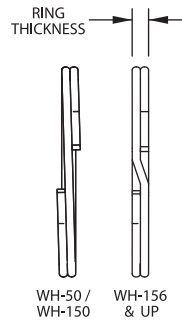
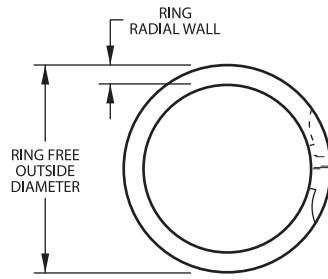

Product Dimensions All dimensions are in inches unless otherwise specified.

Smalley Part Number ^{1,4}	Housing Diameter	Ring			Groove		Thrust Capacity	
		Outside Diameter	Radial Wall	Thickness	Diameter	Width	Groove Yield (lb) ²	Ring Shear (lb) ³
WH-50	.500	.532	.045	.025	.526	.030	460	2,000
WH-51	.512	.544	.045	.025	.538	.030	470	2,050
WH-53	.531	.564	.045	.025	.557	.030	490	2,130
WH-56	.562	.594	.045	.025	.588	.030	520	2,250
WH-59	.594	.626	.045	.025	.619	.030	550	2,380
WH-62	.625	.658	.045	.025	.651	.030	570	2,500
WH-65	.656	.689	.045	.025	.682	.030	600	2,630
WH-68	.687	.720	.045	.025	.713	.030	630	2,750
WH-71	.718	.751	.045	.025	.744	.030	660	2,870
WH-75	.750	.790	.065	.031	.782	.036	850	3,360
WH-77	.777	.817	.065	.031	.808	.036	880	3,480
WH-78	.781	.821	.065	.031	.812	.036	880	3,500
WH-81	.812	.853	.065	.031	.843	.036	920	3,640
WH-84	.843	.889	.065	.031	.880	.036	1,130	3,780
WH-86	.866	.913	.065	.031	.903	.036	1,160	3,880
WH-87	.875	.922	.065	.031	.912	.036	1,180	3,920
WH-90	.906	.949	.065	.031	.939	.036	1,220	4,060
WH-93	.938	.986	.065	.031	.975	.036	1,260	4,200
WH-96	.968	1.025	.075	.037	1.015	.042	1,440	5,180
WH-98	.987	1.041	.075	.037	1.030	.042	1,470	5,280
WH-100	1.000	1.054	.075	.037	1.043	.042	1,480	5,350
WH-102	1.023	1.078	.075	.037	1.066	.042	1,520	5,470
WH-103	1.031	1.084	.075	.037	1.074	.042	1,530	5,510
WH-106	1.062	1.117	.075	.037	1.104	.042	1,580	5,680
WH-109	1.093	1.147	.075	.037	1.135	.042	1,620	5,840
WH-112	1.125	1.180	.075	.037	1.167	.042	1,670	6,020
WH-115	1.156	1.210	.075	.037	1.198	.042	1,720	6,180
WH-118	1.188	1.249	.085	.043	1.236	.048	2,020	7,380
WH-121	1.218	1.278	.085	.043	1.266	.048	2,070	7,570
WH-125	1.250	1.312	.085	.043	1.298	.048	2,120	7,770
WH-128	1.281	1.342	.085	.043	1.329	.048	2,170	7,960
WH-131	1.312	1.374	.085	.043	1.360	.048	2,230	8,150
WH-134	1.343	1.408	.085	.043	1.395	.048	2,470	8,350
WH-137	1.375	1.442	.095	.043	1.427	.048	2,530	8,540
WH-140	1.406	1.472	.095	.043	1.458	.048	2,580	8,740
WH-143	1.437	1.504	.095	.043	1.489	.048	2,640	8,930
WH-145	1.456	1.523	.095	.043	1.508	.048	2,680	9,050
WH-146	1.468	1.535	.095	.043	1.520	.048	2,700	9,120
WH-150	1.500	1.567	.095	.043	1.552	.048	2,760	9,320
WH-156	1.562	1.634	.108	.049	1.617	.056	3,090	10,100
WH-157	1.574	1.649	.108	.049	1.633	.056	3,340	10,180
WH-162	1.625	1.701	.108	.049	1.684	.056	3,350	10,510
WH-165	1.653	1.730	.108	.049	1.712	.056	3,510	10,690
WH-168	1.687	1.768	.118	.049	1.750	.056	3,700	10,910
WH-175	1.750	1.834	.118	.049	1.813	.056	3,840	11,310
WH-181	1.813	1.894	.118	.049	1.875	.056	3,970	11,720
WH-185	1.850	1.937	.118	.049	1.917	.056	4,450	11,960

¹ Add suffix "-S02" for 302 stainless steel, "-S16" for 316 stainless steel.

² Based on a groove material yield strength of 45,000 psi and a safety factor of 2.

³ Based on a safety factor of 3.

⁴ See pages 126-127 for How to Order.

Smalley Part Number ^{1,4}	Housing Diameter	Ring			Groove		Thrust Capacity	
		Outside Diameter	Radial Wall	Thickness	Diameter	Width	Groove Yield (lb) ²	Ring Shear (lb) ³
WH-187	1.875	1.960	.118	.049	1.942	.056	4,510	12,120
WH-193	1.938	2.025	.118	.049	2.005	.056	4,660	12,530
WH-200	2.000	2.091	.128	.049	2.071	.056	4,950	12,930
WH-204	2.047	2.138	.128	.049	2.118	.056	5,060	13,240
WH-206	2.062	2.154	.128	.049	2.132	.056	5,100	13,330
WH-212	2.125	2.217	.128	.049	2.195	.056	5,260	13,740
WH-216	2.165	2.260	.138	.049	2.239	.056	5,660	14,000
WH-218	2.188	2.284	.138	.049	2.262	.056	5,720	14,150
WH-225	2.250	2.347	.138	.049	2.324	.056	5,890	14,550
WH-231	2.312	2.413	.138	.049	2.390	.056	6,370	14,950
WH-237	2.375	2.476	.138	.049	2.453	.056	6,550	15,360
WH-243	2.437	2.543	.148	.049	2.519	.056	7,060	15,760
WH-244	2.440	2.546	.148	.049	2.522	.056	7,070	15,780
WH-250	2.500	2.606	.148	.049	2.582	.056	7,250	16,160
WH-253	2.531	2.641	.148	.049	2.617	.056	7,690	16,360
WH-256	2.562	2.673	.148	.049	2.648	.056	7,790	16,560
WH-262	2.625	2.736	.148	.049	2.711	.056	7,980	16,970
WH-267	2.677	2.789	.158	.049	2.767	.056	8,520	17,310
WH-268	2.688	2.803	.158	.049	2.778	.056	8,550	17,380
WH-275	2.750	2.865	.158	.049	2.841	.056	8,750	17,780
WH-281	2.813	2.929	.158	.049	2.903	.056	8,950	18,190
WH-283	2.834	2.954	.168	.049	2.928	.056	9,520	18,320
WH-287	2.875	2.995	.168	.049	2.969	.056	9,550	18,590
WH-293	2.937	3.058	.168	.049	3.031	.056	9,760	18,990
WH-295	2.952	3.073	.168	.049	3.046	.056	9,810	19,090
WH-300	3.000	3.122	.168	.061	3.096	.068	10,180	24,150
WH-306	3.062	3.186	.168	.061	3.158	.068	10,390	24,650
WH-312	3.125	3.251	.178	.061	3.223	.068	10,600	25,150
WH-314	3.149	3.276	.178	.061	3.247	.068	10,680	25,350
WH-318	3.187	3.311	.178	.061	3.283	.068	10,810	25,650
WH-325	3.250	3.379	.178	.061	3.350	.068	11,490	26,160
WH-331	3.312	3.446	.188	.061	3.416	.068	12,170	26,660
WH-334	3.346	3.479	.188	.061	3.450	.068	12,300	26,930
WH-337	3.375	3.509	.188	.061	3.479	.068	12,410	27,170
WH-343	3.437	3.574	.188	.061	3.543	.068	12,880	27,660
WH-350	3.500	3.636	.188	.061	3.606	.068	13,110	28,170
WH-354	3.543	3.684	.198	.061	3.653	.068	13,770	28,520
WH-356	3.562	3.703	.198	.061	3.672	.068	13,850	28,670
WH-362	3.625	3.769	.198	.061	3.737	.068	14,350	29,180
WH-368	3.687	3.832	.198	.061	3.799	.068	14,600	29,680
WH-374	3.740	3.885	.198	.061	3.852	.068	14,800	30,100
WH-375	3.750	3.894	.198	.061	3.862	.068	14,840	30,180
WH-381	3.812	3.963	.208	.061	3.930	.068	15,900	30,680
WH-387	3.875	4.025	.208	.061	3.993	.068	16,160	31,190
WH-393	3.938	4.089	.208	.061	4.056	.068	16,420	31,700
WH-400	4.000	4.157	.218	.061	4.124	.068	17,530	32,200
WH-406	4.063	4.222	.218	.061	4.187	.068	17,810	32,700
WH-412	4.125	4.284	.218	.061	4.249	.068	18,080	33,200
WH-418	4.188	4.347	.218	.061	4.311	.068	18,350	33,710
WH-425	4.250	4.416	.228	.061	4.380	.068	19,530	34,210
WH-431	4.312	4.479	.228	.061	4.442	.068	19,810	34,710
WH-433	4.330	4.497	.228	.061	4.460	.068	19,900	34,850
WH-437	4.375	4.543	.228	.061	4.505	.068	20,100	35,210
WH-443	4.437	4.611	.238	.061	4.573	.068	21,330	35,710
WH-450	4.500	4.674	.238	.061	4.636	.068	21,630	36,220
WH-452	4.527	4.701	.238	.061	4.663	.068	21,760	36,440
WH-456	4.562	4.737	.238	.061	4.698	.068	21,930	36,720
WH-462	4.625	4.803	.250	.072	4.765	.079	22,890	43,940
WH-468	4.687	4.867	.250	.072	4.827	.079	23,190	44,530
WH-472	4.724	4.903	.250	.072	4.864	.079	23,370	44,880
WH-475	4.750	4.930	.250	.072	4.890	.079	23,500	45,130
WH-481	4.812	4.993	.250	.072	4.952	.079	23,810	45,720

¹ Add suffix "-S02" for 302 stainless steel, "-S16" for 316 stainless steel.

² Based on a groove material yield strength of 45,000 psi and a safety factor of 2.

³ Based on a safety factor of 3.

⁴ See pages 126-127 for How to Order.

Stock Items available in carbon steel and 302 and 316 stainless steel.

Product Dimensions All dimensions are in inches unless otherwise specified.

Smalley Part Number ^{1,4}	Housing Diameter	Ring			Groove		Thrust Capacity	
		Outside Diameter	Radial Wall	Thickness	Diameter	Width	Groove Yield (lb) ²	Ring Shear (lb) ³
WH-487	4.875	5.055	.250	.072	5.015	.079	24,120	46,310
WH-492	4.921	5.102	.250	.072	5.061	.079	24,350	46,750
WH-493	4.937	5.122	.250	.072	5.081	.079	25,130	46,900
WH-500	5.000	5.185	.250	.072	5.144	.079	25,450	47,500
WH-511	5.118	5.304	.250	.072	5.262	.079	26,050	48,620
WH-512	5.125	5.311	.250	.072	5.269	.079	26,100	48,690
WH-525	5.250	5.436	.250	.072	5.393	.079	26,720	49,880
WH-537	5.375	5.566	.250	.072	5.522	.079	28,120	51,060
WH-550	5.500	5.693	.250	.072	5.647	.079	28,770	52,250
WH-551	5.511	5.703	.250	.072	5.658	.079	28,830	52,360
WH-562	5.625	5.818	.250	.072	5.772	.079	29,400	53,440
WH-570	5.708	5.909	.250	.072	5.861	.079	31,070	54,230
WH-575	5.750	5.950	.250	.072	5.903	.079	31,300	54,630
WH-587	5.875	6.077	.250	.072	6.028	.079	31,980	55,810
WH-590	5.905	6.106	.250	.072	6.058	.079	32,140	56,100
WH-600	6.000	6.202	.250	.072	6.153	.079	32,660	57,000
WH-612	6.125	6.349	.312	.086	6.297	.094	37,200	69,500
WH-625	6.250	6.474	.312	.086	6.422	.094	37,990	70,920
WH-629	6.299	6.524	.312	.086	6.471	.094	38,290	71,480
WH-637	6.375	6.601	.312	.086	6.547	.094	38,750	72,340
WH-650	6.500	6.726	.312	.086	6.672	.094	39,510	73,760
WH-662	6.625	6.863	.312	.086	6.807	.094	42,620	75,180
WH-669	6.692	6.931	.312	.086	6.874	.094	43,050	75,940
WH-675	6.750	6.987	.312	.086	6.932	.094	43,420	76,600
WH-687	6.875	7.114	.312	.086	7.057	.094	44,220	78,010
WH-700	7.000	7.239	.312	.086	7.182	.094	45,030	79,430
WH-708	7.086	7.337	.312	.086	7.278	.094	48,080	80,410
WH-712	7.125	7.376	.312	.086	7.317	.094	48,350	80,850
WH-725	7.250	7.501	.312	.086	7.442	.094	49,200	82,270
WH-737	7.375	7.628	.312	.086	7.567	.094	50,050	83,690
WH-748	7.480	7.734	.312	.086	7.672	.094	50,760	84,880
WH-750	7.500	7.754	.312	.086	7.692	.094	50,890	85,110
WH-762	7.625	7.890	.312	.086	7.827	.094	54,440	86,520
WH-775	7.750	8.014	.312	.086	7.952	.094	55,330	87,940
WH-787	7.875	8.131	.312	.086	8.077	.094	63,360	89,360
WH-800	8.000	8.266	.312	.086	8.202	.094	57,110	90,780
WH-825	8.250	8.528	.375	.086	8.462	.094	61,820	93,620
WH-826	8.267	8.546	.375	.086	8.479	.094	61,940	93,810
WH-846	8.464	8.744	.375	.086	8.676	.094	63,420	96,050
WH-850	8.500	8.780	.375	.086	8.712	.094	63,690	96,450
WH-875	8.750	9.041	.375	.086	8.972	.094	68,650	99,290
WH-885	8.858	9.151	.375	.086	9.080	.094	69,500	100,520
WH-900	9.000	9.293	.375	.086	9.222	.094	70,620	102,130
WH-905	9.055	9.359	.375	.086	9.287	.094	74,250	102,750
WH-925	9.250	9.555	.375	.086	9.482	.094	75,850	104,960
WH-944	9.448	9.755	.375	.086	9.680	.094	77,470	107,210
WH-950	9.500	9.806	.375	.086	9.732	.094	77,900	107,800
WH-975	9.750	10.068	.375	.086	9.992	.094	83,390	110,640
WH-1000	10.000	10.320	.375	.086	10.242	.094	85,530	113,470
WH-1025	10.250	10.582	.375	.086	10.502	.094	91,290	116,310
WH-1050	10.500	10.834	.375	.086	10.752	.094	93,520	119,150
WH-1075	10.750	11.095	.375	.086	11.012	.094	99,540	121,990
WH-1100	11.000	11.347	.375	.086	11.262	.094	101,860	124,820

¹ Add suffix "-S02" for 302 stainless steel, "-S16" for 316 stainless steel.

² Based on a groove material strength of 45,000 psi and a safety factor of 2.

³ Based on a safety factor of 3.

⁴ See pages 126-127 for How to Order.

Stock Items available in carbon steel and 17-7PH/C stainless steel.

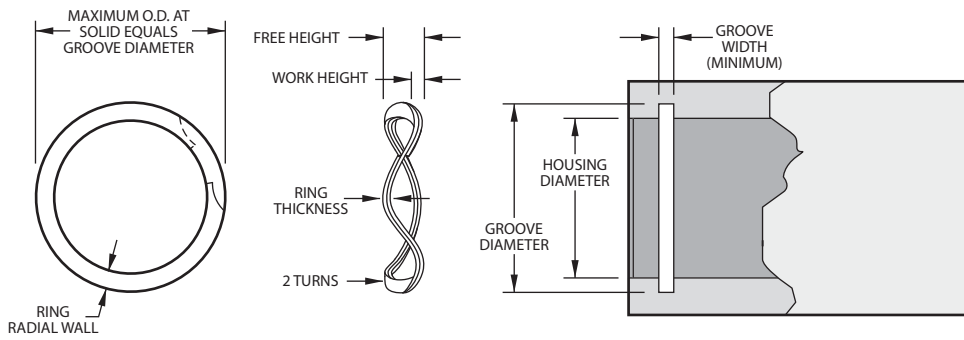

Product Dimensions All dimensions are in inches unless otherwise specified.

Smalley Part Number ^{1,2}	Housing Diameter	Load (lb) @ Work Height	Max. Free Height	Number of Waves	Ring			Groove	
					Thickness	Radial Wall	Crimp	Diameter	Width Min.
WHW-75	.750	25 @ .080	.114	3	.035	.065	N	.796	.119
WHW-87	.875	30 @ .085	.110	3	.042	.085	N	.931	.115
WHW-100	1.000	34 @ .085	.120	3	.042	.085	N	1.066	.125
WHW-112	1.125	38 @ .100	.125	3	.050	.128	N	1.197	.130
WHW-125	1.250	40 @ .100	.135	3	.050	.128	N	1.330	.140
WHW-137	1.375	45 @ .100	.125	4	.050	.128	N	1.461	.130
WHW-150	1.500	50 @ .100	.135	4	.050	.128	N	1.594	.140
WHW-162	1.625	55 @ .110	.135	4	.062	.158	N	1.725	.140
WHW-175	1.750	60 @ .110	.140	4	.062	.158	N	1.858	.145
WHW-187	1.875	63 @ .110	.141	4	.062	.158	N	1.989	.146
WHW-200	2.000	65 @ .110	.150	4	.062	.158	N	2.122	.155
WHW-212	2.125	70 @ .130	.170	4	.078	.188	N	2.251	.175
WHW-225	2.250	75 @ .130	.175	4	.078	.188	N	2.382	.180
WHW-237	2.375	80 @ .130	.180	4	.078	.188	N	2.517	.185
WHW-250	2.500	84 @ .130	.183	4	.078	.188	N	2.648	.188
WHW-262	2.625	88 @ .170	.220	4	.093	.225	N	2.781	.225
WHW-275	2.750	94 @ .170	.229	4	.093	.225	N	2.914	.234
WHW-287	2.875	97 @ .170	.225	4	.093	.225	N	3.051	.230
WHW-300	3.000	100 @ .170	.230	4	.093	.225	N	3.182	.235
WHW-312	3.125	103 @ .185	.250	4	.111	.281	Y	3.315	.255
WHW-325	3.250	106 @ .185	.250	4	.111	.281	Y	3.446	.255
WHW-350	3.500	115 @ .185	.245	4	.111	.281	Y	3.710	.250
WHW-362	3.625	117 @ .185	.250	4	.111	.281	Y	3.841	.250
WHW-375	3.750	121 @ .185	.255	4	.111	.312	Y	3.974	.260
WHW-387	3.875	126 @ .185	.260	4	.111	.312	Y	4.107	.265
WHW-400	4.000	130 @ .185	.255	4	.111	.312	Y	4.240	.260
WHW-412	4.125	134 @ .185	.258	4	.111	.312	Y	4.365	.263
WHW-425	4.250	140 @ .185	.264	4	.111	.312	Y	4.490	.269
WHW-450	4.500	150 @ .185	.250	5	.111	.312	Y	4.740	.255
WHW-475	4.750	160 @ .185	.252	5	.111	.312	Y	4.995	.257
WHW-500	5.000	170 @ .185	.247	5	.111	.312	Y	5.260	.252

¹ Add suffix "-S17" for stainless steel.

² See pages 126-127 for How to Order.

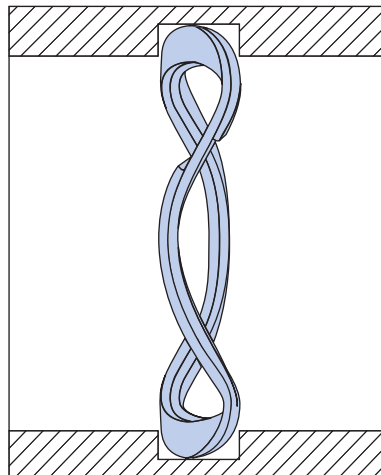

WHT Series

Medium Heavy Duty Rings

Stock Items available in carbon steel and 302 and 316 stainless steel.

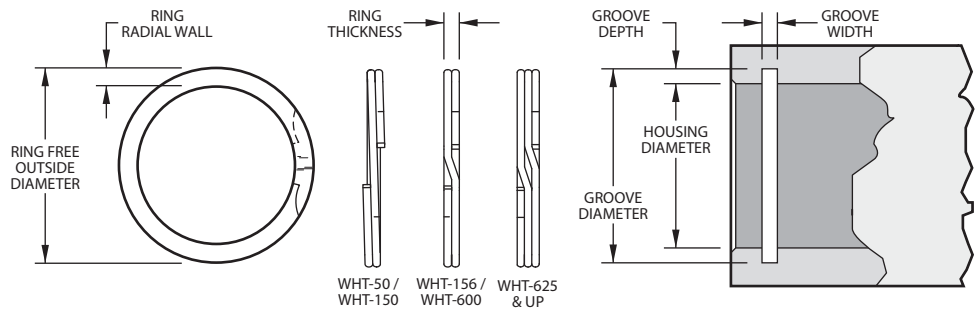
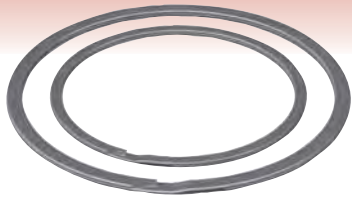

Product Dimensions All dimensions are in inches unless otherwise specified.

Smalley Part Number ^{1,4}	Housing Diameter	Ring			Groove		Thrust Capacity	
		Outside Diameter	Radial Wall	Thickness	Diameter	Width	Groove Yield (lb) ²	Ring Shear (lb) ³
WHT-50	.500	.529	.045	.035	.524 ±.002	.039	420	2,530
WHT-51	.512	.541	.045	.035	.536 ±.002	.039	430	2,590
WHT-56	.562	.597	.045	.035	.592 ±.002	.039	600	2,840
WHT-62	.625	.665	.045	.035	.659 ±.002	.039	750	3,160
WHT-68	.688	.730	.055	.035	.724 ±.002	.039	880	3,480
WHT-75	.750	.796	.055	.035	.790 ±.002	.039	1,060	3,790
WHT-77	.777	.825	.065	.042	.819 ±.002	.046	1,150	4,720
WHT-81	.812	.864	.065	.042	.857 ±.002	.046	1,320	4,930
WHT-86	.866	.919	.065	.042	.912 ±.002	.046	1,410	5,260
WHT-87	.875	.929	.065	.042	.922 ±.002	.046	1,480	5,310
WHT-90	.901	.957	.065	.042	.950 ±.002	.046	1,590	5,470
WHT-93	.938	.997	.075	.042	.989 ±.002	.046	1,720	5,690
WHT-100	1.000	1.063	.075	.042	1.055 ±.002	.046	1,980	6,070
WHT-102	1.023	1.087	.075	.042	1.079 ±.002	.046	2,030	6,210
WHT-106	1.062	1.129	.078	.050	1.120 ±.002	.056	2,180	7,010
WHT-112	1.125	1.195	.078	.050	1.185 ±.002	.056	2,390	7,420
WHT-118	1.188	1.260	.088	.050	1.250 ±.002	.056	2,600	7,840
WHT-125	1.250	1.330	.093	.050	1.320 ±.002	.056	3,090	8,250
WHT-131	1.312	1.395	.093	.050	1.385 ±.002	.056	3,430	8,660
WHT-137	1.375	1.461	.098	.050	1.450 ±.002	.056	3,690	9,070
WHT-143	1.438	1.526	.103	.050	1.515 ±.002	.056	3,960	9,490
WHT-145	1.456	1.546	.108	.050	1.535 ±.002	.056	4,120	9,610
WHT-150	1.500	1.591	.108	.050	1.580 ±.002	.056	4,240	9,900
WHT-156	1.562	1.659	.113	.062	1.647 ±.002	.068	4,750	12,780
WHT-162	1.625	1.727	.113	.062	1.715 ±.002	.068	5,170	13,290
WHT-165	1.653	1.757	.118	.062	1.745 ±.002	.068	5,380	13,520
WHT-168	1.688	1.793	.118	.062	1.780 ±.002	.068	5,490	13,810
WHT-175	1.750	1.858	.118	.062	1.845 ±.002	.068	5,940	14,320
WHT-181	1.812	1.923	.123	.062	1.910 ±.002	.068	6,280	14,820
WHT-185	1.850	1.963	.123	.062	1.949 ±.002	.068	6,540	15,130
WHT-187	1.875	1.989	.128	.062	1.975 ±.002	.068	6,630	15,340
WHT-193	1.938	2.054	.128	.062	2.040 ±.002	.068	6,990	15,850
WHT-200	2.000	2.125	.138	.062	2.110 ±.002	.068	7,780	16,360
WHT-206	2.062	2.190	.141	.078	2.175 ±.002	.086	8,310	21,220
WHT-212	2.125	2.255	.141	.078	2.240 ±.002	.086	8,710	21,870
WHT-218	2.188	2.321	.141	.078	2.305 ±.002	.086	9,130	22,520
WHT-225	2.250	2.386	.141	.078	2.370 ±.002	.086	9,540	23,160
WHT-231	2.312	2.457	.188	.078	2.440 ±.002	.086	10,460	23,800
WHT-237	2.375	2.522	.188	.078	2.505 ±.002	.086	10,910	24,440
WHT-244	2.440	2.588	.188	.078	2.570 ±.002	.086	11,210	25,110
WHT-250	2.500	2.653	.188	.078	2.635 ±.002	.086	12,020	25,730
WHT-253	2.531	2.687	.188	.078	2.668 ±.002	.086	12,350	26,050
WHT-256	2.562	2.720	.188	.093	2.700 ±.002	.103	12,500	29,940
WHT-262	2.625	2.785	.188	.093	2.765 ±.002	.103	12,990	30,680

¹ Add suffix "-S02" for 302 stainless steel, "-S16" for 316 stainless steel.

² Based on a groove material strength of 45,000 psi and a safety factor of 2.

³ Based on a safety factor of 3.

⁴ See pages 126-127 for How to Order.

Smalley Part Number ^{1,4}	Housing Diameter	Ring			Groove		Thrust Capacity	
		Outside Diameter	Radial Wall	Thickness	Diameter	Width	Groove Yield (lb) ²	Ring Shear (lb) ³
WHT-268	2.688	2.855	.188	.093	2.834	.103	13,870	31,410
WHT-275	2.750	2.921	.188	.093	2.900	.103	14,580	32,140
WHT-281	2.813	2.987	.188	.093	2.965	.103	15,110	32,880
WHT-283	2.834	3.009	.188	.093	2.987	.103	15,430	33,120
WHT-287	2.875	3.053	.188	.093	3.030	.103	15,850	33,600
WHT-300	3.000	3.188	.188	.093	3.165	.103	17,600	35,060
WHT-306	3.062	3.253	.250	.111	3.230	.120	18,180	42,710
WHT-312	3.125	3.318	.250	.111	3.295	.120	18,780	43,590
WHT-315	3.156	3.354	.250	.111	3.328	.120	19,190	44,040
WHT-325	3.250	3.450	.250	.111	3.426	.120	20,220	45,330
WHT-334	3.346	3.550	.250	.111	3.525	.120	21,290	46,670
WHT-346	3.464	3.675	.250	.111	3.650	.120	22,770	48,320
WHT-350	3.500	3.716	.250	.111	3.690	.120	23,500	48,820
WHT-354	3.543	3.761	.250	.111	3.735	.120	24,040	49,420
WHT-356	3.562	3.783	.250	.111	3.756	.120	24,420	49,690
WHT-362	3.625	3.849	.250	.111	3.822	.120	25,370	50,560
WHT-375	3.750	3.982	.250	.111	3.955	.120	27,300	52,310
WHT-387	3.875	4.115	.250	.111	4.087	.120	29,030	54,050
WHT-393	3.938	4.178	.250	.111	4.150	.120	29,510	54,930
WHT-400	4.000	4.248	.250	.111	4.220	.120	31,100	55,800
WHT-412	4.125	4.373	.312	.111	4.345	.120	32,070	57,540
WHT-425	4.250	4.500	.312	.111	4.470	.120	33,050	59,280
WHT-433	4.330	4.586	.312	.111	4.556	.120	34,590	60,400
WHT-450	4.500	4.768	.312	.111	4.735	.120	37,530	62,770
WHT-462	4.625	4.897	.312	.111	4.865	.120	39,230	64,510
WHT-475	4.750	5.028	.312	.111	4.995	.120	41,300	66,260
WHT-500	5.000	5.295	.312	.111	5.260	.120	45,950	69,740
WHT-525	5.250	5.559	.375	.127	5.520	.139	50,100	83,790
WHT-537	5.375	5.685	.375	.127	5.645	.139	51,290	85,780
WHT-550	5.500	5.810	.375	.127	5.770	.139	52,480	87,780
WHT-575	5.750	6.062	.375	.127	6.020	.139	54,870	91,770
WHT-600	6.000	6.314	.375	.127	6.270	.139	57,260	95,760

¹ Add suffix "-S02" for 302 stainless steel, "-S16" for 316 stainless steel.

² Based on a groove material yield strength of 45,000 psi and a safety factor of 2.

³ Based on a safety factor of 3.

⁴ See pages 126-127 for How to Order.

Rings listed below are three-turn construction.

Smalley Part Number ^{1,4}	Housing Diameter	Ring			Groove		Thrust Capacity	
		Outside Diameter	Radial Wall	Thickness	Diameter	Width	Groove Yield (lb) ²	Ring Shear (lb) ³
WHT-625	6.250	6.576	.312	.165	6.530	.174	61,850	129,590
WHT-650	6.500	6.837	.312	.165	6.790	.174	66,620	134,780
WHT-662	6.625	6.973	.312	.165	6.925	.174	70,240	137,370
WHT-675	6.750	7.104	.312	.165	7.055	.174	73,000	139,960
WHT-700	7.000	7.366	.312	.165	7.315	.174	78,180	145,140
WHT-725	7.250	7.628	.375	.189	7.575	.209	83,530	172,190
WHT-750	7.500	7.895	.375	.189	7.840	.209	90,120	178,130
WHT-775	7.750	8.156	.375	.189	8.100	.209	95,870	184,070
WHT-800	8.000	8.418	.375	.189	8.360	.209	101,790	190,000
WHT-825	8.250	8.680	.375	.189	8.620	.209	107,880	195,940
WHT-850	8.500	8.942	.375	.189	8.880	.209	114,160	201,880
WHT-875	8.750	9.209	.375	.189	9.145	.209	122,460	207,820
WHT-900	9.000	9.471	.375	.189	9.405	.209	129,140	213,750
WHT-925	9.250	9.736	.375	.189	9.669	.209	137,310	219,690
WHT-950	9.500	9.999	.375	.189	9.930	.209	144,380	225,630
WHT-975	9.750	10.260	.375	.189	10.189	.209	151,620	231,570
WHT-1000	10.000	10.552	.375	.189	10.450	.209	159,040	237,500
WHT-1050	10.500	11.072	.375	.189	10.970	.209	174,420	249,380

¹ Add suffix "-S02" for 302 stainless steel, "-S16" for 316 stainless steel.

² Based on a groove material yield strength of 45,000 psi and a safety factor of 2.

³ Based on a safety factor of 3.

⁴ See pages 126-127 for How to Order.

Stock Items available in carbon steel and 302 and 316 stainless steel.

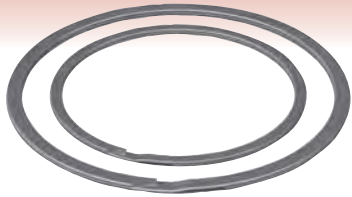

**AS3215, AS4299
MIL-DTL-27426/4**

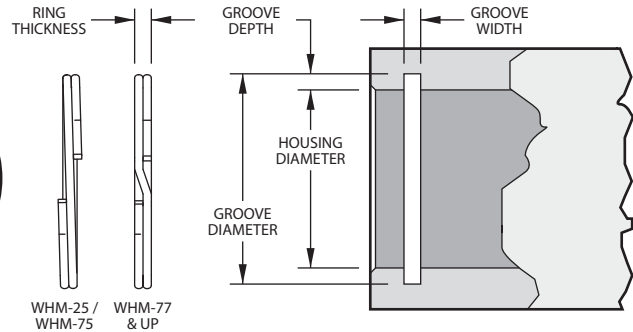
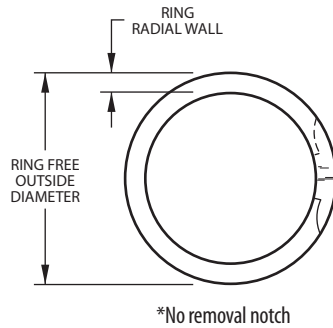

Product Dimensions All dimensions are in inches unless otherwise specified.

Smalley Part Number ^{1,4}	Housing Diameter	Ring			Groove		Thrust Capacity	
		Outside Diameter	Radial Wall	Thickness	Diameter	Width	Groove Yield (lb) ²	Ring Shear (lb) ³
WHM-25*	.250	.270	.020	.015	.268	.020	159	561
WHM-31*	.312	.333	.025	.015	.330	.020	198	700
WHM-37*	.375	.400	.030	.025	.397	.029	292	1,442
WHM-43	.437	.464	.035	.025	.461	.029	371	1,680
WHM-50	.500	.538	.045	.035	.530	.039	530	2,530
WHM-51	.512	.550	.045	.035	.542	.039	540	2,590
WHM-56	.562	.605	.055	.035	.596	.039	680	2,840
WHM-62	.625	.675	.055	.035	.665	.039	880	3,160
WHM-68	.688	.743	.065	.035	.732	.039	1,070	3,480
WHM-75	.750	.807	.065	.035	.796	.039	1,220	3,790
WHM-77	.777	.836	.075	.042	.825	.046	1,320	4,720
WHM-81	.812	.873	.075	.042	.862	.046	1,440	4,930
WHM-86	.866	.931	.075	.042	.920	.046	1,650	5,260
WHM-87	.875	.943	.085	.042	.931	.046	1,730	5,310
WHM-90	.901	.972	.085	.042	.959	.046	1,850	5,470
WHM-93	.938	1.013	.085	.042	1.000	.046	2,060	5,690
WHM-100	1.000	1.080	.085	.042	1.066	.046	2,330	6,070
WHM-102	1.023	1.105	.085	.042	1.091	.046	2,460	6,210
WHM-106	1.062	1.138	.103	.050	1.130	.056	2,550	7,010
WHM-112	1.125	1.205	.103	.050	1.197	.056	2,860	7,420
WHM-118	1.188	1.271	.103	.050	1.262	.056	3,110	7,840
WHM-125	1.250	1.339	.103	.050	1.330	.056	3,530	8,250
WHM-131	1.312	1.406	.118	.050	1.396	.056	3,900	8,660
WHM-137	1.375	1.471	.118	.050	1.461	.056	4,180	9,070
WHM-143	1.439	1.539	.118	.050	1.528	.056	4,580	9,490
WHM-145	1.456	1.559	.118	.050	1.548	.056	4,730	9,610
WHM-150	1.500	1.605	.118	.050	1.594	.056	4,980	9,900
WHM-156	1.562	1.675	.128	.062	1.658	.068	5,300	12,780
WHM-162	1.625	1.742	.128	.062	1.725	.068	5,740	13,290
WHM-165	1.653	1.772	.128	.062	1.755	.068	5,960	13,520
WHM-168	1.688	1.810	.128	.062	1.792	.068	6,210	13,810
WHM-175	1.750	1.876	.128	.062	1.858	.068	6,680	14,320
WHM-181	1.812	1.940	.128	.062	1.922	.068	7,050	14,820
WHM-185	1.850	1.981	.158	.062	1.962	.068	7,320	15,130
WHM-187	1.875	2.008	.158	.062	1.989	.068	7,560	15,340
WHM-193	1.938	2.075	.158	.062	2.056	.068	8,080	15,850
WHM-200	2.000	2.142	.158	.062	2.122	.068	8,620	16,360
WHM-206	2.062	2.201	.168	.078	2.186	.086	9,040	21,220
WHM-212	2.125	2.267	.168	.078	2.251	.086	9,460	21,870
WHM-218	2.188	2.334	.168	.078	2.318	.086	10,050	22,520
WHM-225	2.250	2.399	.168	.078	2.382	.086	10,500	23,160
WHM-231	2.312	2.467	.200	.078	2.450	.086	11,280	23,800
WHM-237	2.375	2.535	.200	.078	2.517	.086	11,920	24,440
WHM-244	2.440	2.602	.200	.078	2.584	.086	12,420	25,110
WHM-250	2.500	2.667	.200	.078	2.648	.086	13,080	25,730
WHM-253	2.531	2.700	.200	.078	2.681	.086	13,420	26,050
WHM-256	2.562	2.733	.225	.093	2.714	.103	13,760	29,940
WHM-262	2.625	2.801	.225	.093	2.781	.103	14,470	30,680
WHM-268	2.688	2.868	.225	.093	2.848	.103	15,200	31,410
WHM-275	2.750	2.934	.225	.093	2.914	.103	15,940	32,140
WHM-281	2.813	3.001	.225	.093	2.980	.103	16,700	32,880

¹ Add suffix "-S02" for 302 stainless steel, "-S16" for 316 stainless steel.

² Based on a groove material yield strength of 45,000 psi and a safety factor of 2.

³ Based on a safety factor of 3.

⁴ See pages 126-127 for How to Order.

Smalley Part Number ^{1,4}	Housing Diameter	Ring			Groove		Thrust Capacity	
		Outside Diameter	Radial Wall	Thickness	Diameter	Width	Groove Yield (lb) ²	Ring Shear (lb) ³
WHM-283	2.834	3.027	.225	.093	3.006	.103	17,230	33,120
WHM-287	2.875	3.072	.225	.093	3.051	.103	17,880	33,600
WHM-300	3.000	3.204	.225	.093	3.182	.103	18,300	35,060
WHM-306	3.062	3.271	.281	.111	3.248	.120	20,130	42,710
WHM-312	3.125	3.338	.281	.111	3.315	.120	20,990	43,590
WHM-315	3.157	3.371	.281	.111	3.348	.120	21,420	44,040
WHM-325	3.250	3.470	.281	.111	3.446	.120	22,510	45,330
WHM-334	3.346	3.571	.281	.111	3.546	.120	23,650	46,670
WHM-347	3.464	3.701	.281	.111	3.675	.120	25,710	48,320
WHM-350	3.500	3.736	.281	.111	3.710	.120	25,980	48,820
WHM-354	3.543	3.781	.281	.111	3.755	.120	26,550	49,420
WHM-356	3.562	3.802	.281	.111	3.776	.120	26,940	49,690
WHM-362	3.625	3.868	.281	.111	3.841	.120	27,670	50,560
WHM-375	3.750	4.002	.312	.111	3.974	.120	29,690	52,310
WHM-387	3.875	4.136	.312	.111	4.107	.120	31,770	54,050
WHM-393	3.938	4.203	.312	.111	4.174	.120	32,850	54,930
WHM-400	4.000	4.270	.312	.111	4.240	.120	33,930	55,800
WHM-412	4.125	4.369	.312	.111	4.339	.120	34,990	57,540
WHM-425	4.250	4.501	.312	.111	4.470	.120	36,050	59,280
WHM-433	4.330	4.588	.312	.111	4.556	.120	36,730	60,400
WHM-450	4.500	4.768	.312	.111	4.735	.120	38,170	62,770
WHM-462	4.625	4.899	.312	.111	4.865	.120	39,230	64,510
WHM-475	4.750	5.030	.312	.111	4.995	.120	41,300	66,260
WHM-500	5.000	5.297	.312	.111	5.260	.120	45,950	69,740
WHM-525	5.250	5.559	.350	.127	5.520	.139	50,100	83,790
WHM-537	5.375	5.690	.350	.127	5.650	.139	51,290	85,780
WHM-550	5.500	5.810	.350	.127	5.770	.139	52,480	87,780
WHM-575	5.750	6.062	.350	.127	6.020	.139	54,870	91,770
WHM-600	6.000	6.314	.350	.127	6.270	.139	57,260	95,760
WHM-625	6.250	6.576	.380	.156	6.530	.174	61,850	122,520
WHM-650	6.500	6.838	.380	.156	6.790	.174	66,620	127,420
WHM-662	6.625	6.974	.380	.156	6.925	.174	70,240	129,870
WHM-675	6.750	7.105	.380	.156	7.055	.174	73,000	132,320
WHM-700	7.000	7.366	.380	.156	7.315	.174	78,180	137,230
WHM-725	7.250	7.628	.418	.187	7.575	.209	83,530	170,370
WHM-750	7.500	7.895	.418	.187	7.840	.209	90,120	176,240
WHM-775	7.750	8.157	.418	.187	8.100	.209	95,870	182,120
WHM-800	8.000	8.419	.418	.187	8.360	.209	101,790	187,990
WHM-825	8.250	8.680	.437	.187	8.620	.209	107,880	193,870
WHM-850	8.500	8.942	.437	.187	8.880	.209	114,160	199,740
WHM-875	8.750	9.209	.437	.187	9.145	.209	122,460	205,620
WHM-900	9.000	9.471	.437	.187	9.405	.209	129,140	211,490
WHM-925	9.250	9.737	.437	.187	9.669	.209	137,310	217,370
WHM-950	9.500	10.000	.500	.187	9.930	.209	144,380	223,240
WHM-975	9.750	10.260	.500	.187	10.189	.209	150,620	229,120
WHM-1000	10.000	10.523	.500	.187	10.450	.209	159,040	234,990
WHM-1025	10.250	10.786	.500	.187	10.711	.209	167,370	240,870
WHM-1050	10.500	11.047	.500	.187	10.970	.209	174,420	246,740
WHM-1075	10.750	11.313	.500	.187	11.234	.209	183,890	252,620
WHM-1100	11.000	11.575	.500	.187	11.495	.209	192,830	258,490
WHM-1125	11.250	11.838	.500	.187	11.756	.209	201,190	264,370
WHM-1150	11.500	12.102	.562	.187	12.018	.209	210,540	270,240
WHM-1175	11.750	12.365	.562	.187	12.279	.209	220,100	276,120
WHM-1200	12.000	12.628	.562	.187	12.540	.209	229,020	281,990
WHM-1225	12.250	12.891	.562	.187	12.801	.209	238,990	287,860
WHM-1250	12.500	13.154	.562	.187	13.063	.209	249,170	293,740
WHM-1275	12.750	13.417	.562	.187	13.324	.209	258,660	299,610
WHM-1300	13.000	13.680	.662	.187	13.585	.209	269,240	305,490
WHM-1325	13.250	13.943	.662	.187	13.846	.209	279,100	311,360
WHM-1350	13.500	14.207	.662	.187	14.108	.209	290,100	317,240
WHM-1375	13.750	14.470	.662	.187	14.369	.209	301,300	323,110
WHM-1400	14.000	14.732	.662	.187	14.630	.209	311,730	328,990
WHM-1425	14.250	14.995	.662	.187	14.891	.209	323,340	334,860
WHM-1450	14.500	15.259	.750	.187	15.153	.209	335,160	340,740
WHM-1475	14.750	15.522	.750	.187	15.414	.209	346,150	346,610
WHM-1500	15.000	15.785	.750	.187	15.675	.209	358,380	352,490

¹ Add suffix "-S02" for 302 stainless steel, "-S16" for 316 stainless steel.

² Based on a groove material yield strength of 45,000 psi and a safety factor of 2.

³ Based on a safety factor of 3.

⁴ See pages 126-127 for How to Order.

Stock Items available in carbon steel and 302 stainless steel.

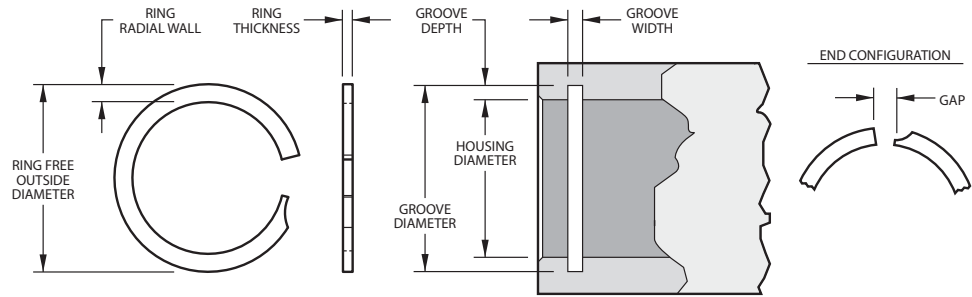
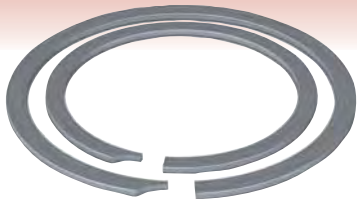

Product Dimensions All dimensions are in inches unless otherwise specified.

Smalley Part Number ^{1,4}	Housing Diameter	Ring			Groove		Thrust Capacity	
		Outside Diameter	Radial Wall	Thickness	Diameter	Width	Groove Yield (lb) ²	Ring Shear (lb) ³
FHE-0050	.500	.529	.055	.037	.524	.043	424	2,325
FHE-0056	.562	.591	.055	.037	.586	.043	477	2,613
FHE-0062	.625	.665	.065	.037	.657	.043	707	2,906
FHE-0068	.687	.726	.065	.037	.719	.043	777	3,194
FHE-0075	.750	.797	.075	.037	.790	.043	1,060	3,487
FHE-0081	.812	.860	.075	.037	.852	.043	1,148	3,775
FHE-0087	.875	.924	.075	.037	.915	.043	1,237	4,068
FHE-0093	.937	1.000	.085	.045	.985	.051	1,590	5,334
FHE-0100	1.000	1.058	.085	.045	1.048	.051	1,696	5,693
FHE-0106	1.062	1.121	.094	.045	1.110	.051	1,802	6,045
FHE-0112	1.125	1.192	.094	.045	1.181	.051	2,227	6,404
FHE-0118	1.187	1.252	.094	.045	1.243	.051	2,349	6,757
FHE-0125	1.250	1.336	.094	.045	1.316	.051	2,916	7,116
FHE-0131	1.312	1.391	.094	.045	1.378	.051	3,060	7,469
FHE-0137	1.375	1.470	.128	.057	1.453	.063	3,791	9,307
FHE-0143	1.437	1.529	.128	.057	1.515	.063	3,961	9,727
FHE-0150	1.500	1.592	.128	.057	1.578	.063	4,135	10,153
FHE-0156	1.562	1.687	.158	.067	1.666	.073	5,741	12,400
FHE-0162	1.625	1.746	.158	.067	1.729	.073	5,973	12,901
FHE-0168	1.687	1.808	.158	.067	1.791	.073	6,201	13,393
FHE-0175	1.750	1.885	.158	.067	1.862	.073	6,927	13,893
FHE-0181	1.812	1.942	.158	.067	1.924	.073	7,173	14,385
FHE-0187	1.875	2.007	.158	.067	1.987	.073	7,422	14,885
FHE-0193	1.937	2.074	.200	.076	2.055	.085	8,078	16,649
FHE-0200	2.000	2.143	.200	.076	2.118	.085	8,341	17,191
FHE-0206	2.062	2.200	.200	.076	2.180	.085	8,599	17,724
FHE-0212	2.125	2.264	.200	.076	2.243	.085	8,862	18,265
FHE-0218	2.187	2.327	.200	.076	2.305	.085	9,121	18,798
FHE-0225	2.250	2.389	.200	.076	2.368	.085	9,384	19,340
FHE-0231	2.312	2.453	.200	.076	2.430	.085	9,642	19,873
FHE-0237	2.375	2.517	.200	.076	2.493	.085	9,905	20,414
FHE-0243	2.437	2.582	.200	.076	2.555	.085	10,163	20,947
FHE-0250	2.500	2.643	.200	.076	2.618	.085	10,426	21,488
FHE-0256	2.562	2.705	.200	.095	2.680	.104	10,685	26,225
FHE-0262	2.625	2.777	.200	.095	2.743	.104	10,947	26,870
FHE-0268	2.687	2.828	.200	.095	2.805	.104	11,206	27,504
FHE-0275	2.750	2.899	.200	.095	2.868	.104	11,469	28,149
FHE-0281	2.812	2.958	.200	.095	2.930	.104	11,727	28,784
FHE-0287	2.875	3.022	.200	.095	2.993	.104	11,990	29,429
FHE-0293	2.937	3.084	.200	.095	3.055	.104	12,249	30,063
FHE-0300	3.000	3.145	.200	.095	3.118	.104	12,511	30,708
FHE-0306	3.062	3.218	.200	.095	3.184	.104	13,203	31,343
FHE-0312	3.125	3.294	.237	.095	3.263	.104	15,242	31,988
FHE-0318	3.187	3.357	.237	.095	3.325	.104	15,544	32,622
FHE-0325	3.250	3.420	.237	.095	3.388	.104	15,851	33,267

¹ Add suffix "-S02" for 302 stainless steel.

² Based on a groove material yield strength of 45,000 psi and a safety factor of 2.

³ Based on a safety factor of 3.

⁴ See pages 126-127 for How to Order.

Smalley Part Number ^{1,4}	Housing Diameter	Ring			Groove		Thrust Capacity	
		Outside Diameter	Radial Wall	Thickness	Diameter	Width	Groove Yield (lb) ²	Ring Shear (lb) ³
FHE-0331	3.312	3.483	.248	.115	3.450	.124	16,154	38,952
FHE-0337	3.375	3.547	.248	.115	3.513	.124	16,461	39,693
FHE-0343	3.437	3.609	.248	.115	3.575	.124	16,763	40,422
FHE-0350	3.500	3.673	.248	.115	3.638	.124	17,071	41,163
FHE-0356	3.562	3.728	.248	.115	3.700	.124	17,373	41,892
FHE-0362	3.625	3.799	.248	.115	3.763	.124	17,680	42,633
FHE-0368	3.687	3.862	.248	.115	3.825	.124	17,983	43,362
FHE-0375	3.750	3.922	.248	.115	3.888	.124	18,290	44,103
FHE-0381	3.812	3.988	.248	.115	3.950	.124	18,592	44,832
FHE-0387	3.875	4.044	.248	.115	4.013	.124	18,900	45,573
FHE-0393	3.937	4.114	.248	.115	4.075	.124	19,202	46,302
FHE-0400	4.000	4.223	.265	.153	4.158	.163	22,337	60,283
FHE-0412	4.125	4.329	.265	.153	4.283	.163	23,035	62,166
FHE-0425	4.250	4.452	.265	.153	4.408	.163	23,733	64,050
FHE-0437	4.375	4.576	.265	.153	4.533	.163	24,431	65,934
FHE-0450	4.500	4.703	.265	.153	4.658	.163	25,129	67,818
FHE-0462	4.625	4.829	.265	.153	4.783	.163	25,827	69,702
FHE-0475	4.750	4.945	.265	.153	4.908	.163	26,525	71,585
FHE-0487	4.875	5.082	.265	.153	5.033	.163	27,223	73,469
FHE-0500	5.000	5.207	.265	.153	5.158	.163	27,921	75,353
FHE-0525	5.250	5.460	.265	.153	5.408	.163	29,317	79,121
FHE-0550	5.500	5.719	.265	.153	5.658	.163	30,713	82,888
FHE-0575	5.750	5.965	.265	.153	5.908	.163	32,109	86,656
FHE-0600	6.000	6.256	.316	.153	6.196	.163	41,563	90,424
FHE-0625	6.250	6.508	.316	.153	6.446	.163	43,295	94,191
FHE-0650	6.500	6.760	.316	.153	6.696	.163	45,027	97,959
FHE-0675	6.750	7.013	.316	.153	6.946	.163	46,759	101,727
FHE-0700	7.000	7.266	.316	.153	7.196	.163	48,490	105,494
FHE-0725	7.250	7.541	.316	.153	7.446	.163	50,222	109,262
FHE-0750	7.500	7.762	.316	.153	7.696	.163	51,954	113,030
FHE-0775	7.750	8.023	.316	.153	7.946	.163	53,686	116,797
FHE-0800	8.000	8.276	.316	.153	8.196	.163	55,418	120,565
FHE-0825	8.250	8.580	.373	.192	8.486	.203	68,813	147,399
FHE-0850	8.500	8.821	.373	.192	8.736	.203	70,898	151,866
FHE-0875	8.750	9.073	.373	.192	8.986	.203	72,983	156,332
FHE-0900	9.000	9.326	.373	.192	9.236	.203	75,068	160,799
FHE-0925	9.250	9.580	.373	.192	9.486	.203	77,154	165,265
FHE-0950	9.500	9.831	.373	.192	9.736	.203	79,239	169,732
FHE-0975	9.750	10.083	.373	.192	9.986	.203	81,324	174,199
FHE-1000	10.000	10.414	.435	.192	10.314	.203	110,977	178,665
FHE-1025	10.250	10.660	.435	.192	10.564	.203	113,751	183,132
FHE-1050	10.500	10.919	.435	.192	10.814	.203	116,526	187,599
FHE-1075	10.750	11.171	.435	.192	11.064	.203	119,300	192,065
FHE-1100	11.000	11.440	.435	.192	11.314	.203	122,074	196,532

¹ Add suffix "-S02" for 302 stainless steel.

² Based on a groove material yield strength of 45,000 psi and a safety factor of 2.

³ Based on a safety factor of 3.

⁴ See pages 126-127 for How to Order.

VHM Series

Metric Light Duty Rings

Stock Items available in carbon steel and 302 and 316 stainless steel.

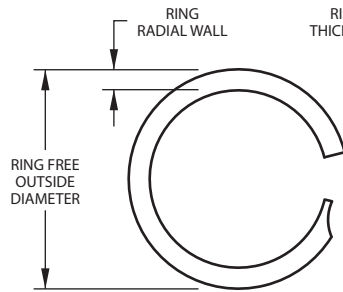
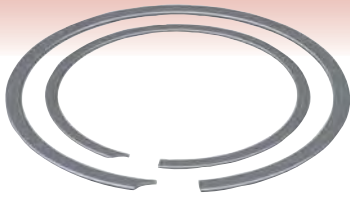

*No removal notch

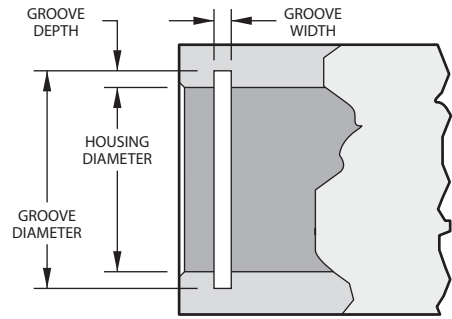

Product Dimensions All dimensions are in millimeters unless otherwise specified.

Smalley Part Number ^{1,4}	Housing Diameter	Ring			Groove		Thrust Capacity	
		Outside Diameter	Radial Wall	Thickness	Diameter	Width	Groove Yield (kN) ²	Ring Shear (kN) ³
VHM-6*	6.00	6.35	.51	.30	6.30	.38	.44	1.99
VHM-7*	7.00	7.38	.51	.30	7.32	.38	.55	2.32
VHM-8*	8.00	8.44	.64	.38	8.36	.46	.70	3.18
VHM-9*	9.00	9.54	.76	.38	9.46	.46	1.00	3.58
VHM-10*	10.00	10.58	.76	.38	10.50	.46	1.24	3.98
VHM-11	11.00	11.68	.89	.38	11.60	.46	1.63	4.39
VHM-12	12.00	12.74	.89	.38	12.66	.46	1.93	4.77
VHM-13	13.00	13.80	1.14	.46	13.72	.56	2.28	6.26
VHM-14	14.00	14.80	1.14	.46	14.72	.56	2.46	6.74
VHM-15	15.00	15.80	1.14	.46	15.72	.56	2.63	7.22
VHM-16	16.00	16.80	1.14	.46	16.72	.56	2.81	7.71
VHM-17	17.00	17.82	1.14	.46	17.72	.56	2.98	8.19
VHM-18	18.00	18.82	1.14	.46	18.72	.56	3.16	8.67
VHM-19	19.00	19.86	1.14	.46	19.76	.56	3.52	9.15
VHM-20	20.00	21.26	1.65	.53	21.06	.66	5.17	11.10
VHM-21	21.00	22.27	1.65	.53	22.06	.66	5.42	11.65
VHM-22	22.00	23.28	1.65	.53	23.06	.66	5.68	12.21
VHM-24	24.00	25.29	1.65	.53	25.06	.66	6.20	13.32
VHM-25	25.00	26.30	1.65	.53	26.06	.66	6.46	13.87
VHM-26	26.00	27.31	1.65	.53	27.06	.66	6.72	14.43
VHM-28	28.00	29.40	2.24	.64	29.12	.79	7.64	16.30
VHM-29	29.00	30.41	2.24	.64	30.12	.79	7.91	16.88
VHM-30	30.00	31.42	2.24	.64	31.12	.79	8.19	17.47
VHM-31	31.00	32.43	2.24	.64	32.12	.79	8.46	18.05
VHM-32	32.00	33.44	2.24	.64	33.12	.79	8.73	18.63
VHM-34	34.00	35.45	2.24	.64	35.12	.79	9.28	19.80
VHM-35	35.00	36.47	2.24	.64	36.12	.79	9.55	20.38
VHM-36	36.00	37.48	2.24	.64	37.12	.79	9.83	20.96
VHM-37	37.00	38.49	2.24	.64	38.12	.79	10.10	21.54
VHM-38	38.00	39.50	2.24	.64	39.12	.79	10.37	22.12
VHM-40	40.00	41.94	3.00	.79	41.48	.99	14.43	28.75
VHM-42	42.00	43.96	3.00	.79	43.48	.99	15.15	30.19
VHM-45	45.00	46.99	3.00	.79	46.48	.99	16.23	32.34
VHM-47	47.00	49.00	3.00	.79	48.48	.99	16.95	33.78
VHM-48	48.00	50.01	3.00	.79	49.48	.99	17.31	34.50
VHM-50	50.00	52.04	3.00	.79	51.48	.99	18.03	35.93
VHM-52	52.00	54.55	4.01	.79	53.94	.99	24.58	37.37
VHM-55	55.00	57.57	4.01	.79	56.94	.99	26.00	39.53
VHM-56	56.00	58.58	4.01	.79	57.94	.99	26.47	40.25
VHM-58	58.00	60.60	4.01	.79	59.94	.99	27.42	41.68
VHM-60	60.00	62.64	4.01	.79	61.94	.99	28.36	43.12
VHM-62	62.00	64.67	4.01	.79	63.94	.99	29.31	44.56
VHM-63	63.00	65.69	4.01	.79	64.94	.99	29.78	45.28
VHM-65	65.00	67.70	4.01	.79	66.94	.99	30.73	46.72
VHM-68	68.00	70.72	4.01	.79	69.94	.99	32.15	48.87
VHM-70	70.00	72.74	4.01	.79	71.94	.99	33.09	50.31
VHM-72	72.00	74.77	4.01	.79	73.94	.99	34.04	51.75
VHM-75	75.00	77.80	4.01	.79	76.94	.99	35.46	53.90

¹ Add suffix "-S02" for 302 stainless steel. Add suffix "-S16" for 316 stainless steel.

² Based on a groove material yield strength of 310 N/mm² and a safety factor of 2.

³ Based on a safety factor of 3.

⁴ See pages 126-127 for How to Order.

Smalley Part Number ^{1,4}	Housing Diameter	Ring			Groove		Thrust Capacity	
		Outside Diameter	Radial Wall	Thickness	Diameter	Width	Groove Yield (kN) ²	Ring Shear (kN) ³
VHM-78	78.00	81.20	4.78	.99	80.34	1.12	44.48	70.25
VHM-80	80.00	83.23	4.78	.99	82.34	1.12	45.62	72.05
VHM-82	82.00	85.25	4.78	.99	84.34	1.12	46.76	73.85
VHM-85	85.00	88.29	4.78	.99	87.34	1.12	48.47	76.55
VHM-88	88.00	91.32	4.78	.99	90.34	1.12	50.18	79.26
VHM-90	90.00	93.36	4.78	.99	92.34	1.12	51.32	81.06
VHM-92	92.00	95.37	4.78	.99	94.34	1.12	52.46	82.86
VHM-95	95.00	98.39	4.78	.99	97.34	1.12	54.17	85.56
VHM-98	98.00	101.41	4.78	.99	100.34	1.12	55.88	88.26
VHM-100	100.00	103.43	4.78	.99	102.34	1.12	57.02	90.06
VHM-102	102.00	105.44	4.78	.99	104.34	1.12	58.16	91.87
VHM-105	105.00	108.92	5.72	1.17	107.80	1.32	71.64	106.44
VHM-110	110.00	113.98	5.72	1.17	112.80	1.32	75.05	111.51
VHM-112	112.00	116.01	5.72	1.17	114.80	1.32	76.42	113.54
VHM-115	115.00	119.12	5.72	1.17	117.88	1.32	80.71	116.58
VHM-120	120.00	124.30	5.72	1.17	123.00	1.32	87.73	121.65
VHM-125	125.00	129.47	5.72	1.17	128.12	1.32	95.04	126.71
VHM-130	130.00	134.66	5.72	1.17	133.26	1.32	103.27	131.78
VHM-135	135.00	139.83	5.72	1.55	138.38	1.70	111.19	181.30
VHM-140	140.00	145.00	5.72	1.55	143.50	1.70	119.40	188.01
VHM-150	150.00	155.30	6.73	1.55	153.76	1.70	137.44	201.44
VHM-155	155.00	160.46	6.73	1.55	158.88	1.70	146.36	208.16
VHM-160	160.00	165.64	6.73	1.55	164.00	1.70	155.96	214.87
VHM-165	165.00	170.82	6.73	1.55	169.13	1.70	165.86	221.59
VHM-170	170.00	175.99	6.73	1.55	174.25	1.70	176.06	228.30
VHM-175	175.00	181.17	6.73	1.55	179.38	1.70	186.57	235.02
VHM-180	180.00	186.35	6.73	1.55	184.50	1.70	197.38	241.73
VHM-185	185.00	191.52	6.73	1.55	189.63	1.70	208.50	248.45
VHM-190	190.00	196.70	6.73	1.55	194.75	1.70	219.92	255.16
VHM-195	195.00	201.87	7.62	1.55	199.88	1.70	231.65	261.88
VHM-200	200.00	207.05	7.62	1.55	205.00	1.70	243.68	268.59
VHM-210	210.00	217.40	7.62	1.55	215.25	1.70	268.66	282.02
VHM-220	220.00	227.76	8.76	1.93	225.50	2.08	294.85	367.88
VHM-230	230.00	238.11	8.76	1.93	235.75	2.08	322.27	384.60
VHM-240	240.00	248.46	8.76	1.93	246.00	2.08	350.90	401.33
VHM-250	250.00	258.81	8.76	1.93	256.25	2.08	380.75	418.05
VHM-260	260.00	269.17	9.65	1.93	266.50	2.08	411.82	434.77
VHM-270	270.00	279.52	9.65	1.93	276.75	2.08	444.11	451.49
VHM-280	280.00	289.87	9.65	1.93	287.00	2.08	477.61	468.21
VHM-290	290.00	300.22	9.65	1.93	297.25	2.08	512.34	484.94
VHM-300	300.00	310.58	9.65	1.93	307.50	2.08	548.28	501.66

¹ Add suffix "-S02" for 302 stainless steel. Add suffix "-S16" for 316 stainless steel.

² Based on a groove material yield strength of 310 N/mm² and a safety factor of 2.

³ Based on a safety factor of 3.

⁴ See pages 126-127 for How to Order.

Stock Items available in carbon steel and 302 and 316 stainless steel.

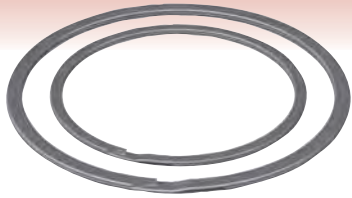

MA 4017⁵

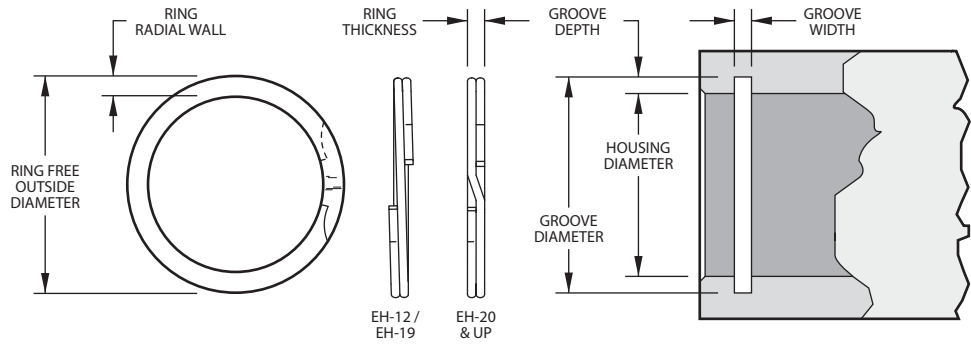

Product Dimensions All dimensions are in millimeters unless otherwise specified.

Smalley Part Number ^{1,4}	Housing Diameter	Ring			Groove		Thrust Capacity	
		Outside Diameter	Radial Wall	Thickness	Diameter	Width	Groove Yield (kN) ²	Ring Shear (kN) ³
EH-12	12.00	12.89	1.02 - 1.22	.60	12.70	.70	2,050	7,950
EH-13	13.00	13.95	1.02 - 1.22	.89	13.75	1.00	2,410	12,110
EH-14	14.00	15.07	1.27 - 1.47	.89	14.85	1.00	2,930	13,040
EH-15	15.00	16.14	1.27 - 1.47	.89	15.90	1.00	3,290	13,970
EH-16	16.00	17.15	1.27 - 1.47	.89	16.95	1.00	3,740	14,900
EH-17	17.00	18.32	1.52 - 1.73	.89	18.05	1.00	4,390	15,830
EH-18	18.00	19.39	1.52 - 1.73	.89	19.10	1.00	4,820	16,760
EH-19	19.00	20.48	1.52 - 1.73	.89	20.17	1.00	5,460	17,690
EH-20	20.00	21.51	1.78 - 1.98	.89	21.22	1.00	5,940	18,620
EH-21	21.00	22.56	1.78 - 1.98	.89	22.27	1.00	6,550	19,550
EH-22	22.00	23.65	1.78 - 1.98	1.07	23.37	1.20	7,390	24,630
EH-23	23.00	24.69	2.03 - 2.24	1.07	24.42	1.20	7,950	25,750
EH-24	24.00	25.73	2.03 - 2.24	1.07	25.47	1.20	8,650	26,870
EH-25	25.00	27.03	2.03 - 2.24	1.07	26.67	1.20	10,230	27,990
EH-26	26.00	28.07	2.03 - 2.24	1.07	27.77	1.20	11,270	29,110
EH-27	27.00	29.11	2.49 - 2.69	1.27	28.87	1.40	12,360	31,170
EH-28	28.00	30.10	2.49 - 2.69	1.27	29.87	1.40	12,820	32,330
EH-29	29.00	31.21	2.49 - 2.69	1.27	30.95	1.40	13,840	33,480
EH-30	30.00	32.28	2.49 - 2.69	1.27	32.00	1.40	14,610	34,640
EH-31	31.00	33.32	2.49 - 2.69	1.27	33.05	1.40	15,550	35,790
EH-32	32.00	34.23	2.49 - 2.69	1.27	34.00	1.40	15,880	36,950
EH-34	34.00	36.46	2.87 - 3.07	1.27	36.20	1.40	18,210	39,260
EH-35	35.00	37.55	2.87 - 3.07	1.27	37.30	1.40	19,600	40,410
EH-36	36.00	38.68	2.87 - 3.07	1.27	38.40	1.40	21,040	41,560
EH-37	37.00	39.60	2.87 - 3.07	1.27	39.40	1.40	21,620	42,720
EH-38	38.00	40.77	2.87 - 3.07	1.27	40.50	1.40	23,130	43,870
EH-40	40.00	42.91	3.12 - 3.33	1.57	42.50	1.75	24,350	57,090
EH-42	42.00	45.01	3.12 - 3.33	1.57	44.60	1.75	26,590	59,950
EH-45	45.00	48.13	3.12 - 3.33	1.57	47.70	1.75	29,590	64,230
EH-46	46.00	49.28	3.12 - 3.33	1.57	48.80	1.75	31,370	65,660
EH-47	47.00	50.32	3.89 - 4.09	1.57	49.90	1.75	33,190	67,080
EH-48	48.00	51.46	3.89 - 4.09	1.57	51.00	1.75	35,070	68,510
EH-50	50.00	53.66	3.89 - 4.09	1.57	53.20	1.75	38,960	71,370
EH-52	52.00	54.30	3.12 - 3.33	1.25	53.79	1.42	22,790	59,090
EH-53	53.00	55.32	3.12 - 3.33	1.25	54.79	1.42	23,230	60,230
EH-55	55.00	57.38	3.38 - 3.58	1.25	56.85	1.42	24,910	62,500
EH-56	56.00	58.40	3.38 - 3.58	1.25	57.85	1.42	25,360	63,640
EH-58	58.00	60.43	3.38 - 3.58	1.25	59.85	1.42	26,270	65,910
EH-59	59.00	61.54	3.38 - 3.58	1.25	60.93	1.42	27,870	67,050
EH-60	60.00	62.57	3.38 - 3.58	1.25	61.99	1.42	29,220	68,180
EH-61	61.00	63.65	3.63 - 3.84	1.25	63.09	1.42	31,190	69,320
EH-62	62.00	64.70	3.63 - 3.84	1.25	64.09	1.42	31,700	70,460
EH-63	63.00	65.70	3.63 - 3.84	1.25	65.09	1.42	32,220	71,590
EH-64	64.00	66.77	3.63 - 3.84	1.25	66.19	1.42	34,290	72,730
EH-65	65.00	67.82	3.63 - 3.84	1.25	67.19	1.42	34,820	73,870
EH-66	66.00	68.80	3.63 - 3.84	1.25	68.19	1.42	35,360	75,000
EH-67	67.00	69.90	3.63 - 3.84	1.25	69.25	1.42	36,870	76,140

¹ Add suffix "-S02" for 302 stainless steel, "-S16" for 316 stainless steel.

² Based on a groove material yield strength of 310 N/mm² and a safety factor of 2.

³ Based on a safety factor of 3.

⁴ See pages 126-127 for How to Order.

⁵ Contact Smalley for details/information on how to order parts to be in compliance with this specification.

Smalley Part Number ^{1,4}	Housing Diameter	Ring			Groove		Thrust Capacity	
		Outside Diameter	Radial Wall	Thickness	Diameter	Width	Groove Yield (kN) ²	Ring Shear (kN) ³
EH-68	68.00	70.94	3.89 - 4.09	1.25	70.29	1.42	38,090	77,270
EH-69	69.00	71.94	3.89 - 4.09	1.25	71.29	1.42	38,650	78,410
EH-70	70.00	72.94	3.89 - 4.09	1.25	72.29	1.42	39,210	79,550
EH-71	71.00	73.99	3.89 - 4.09	1.25	73.29	1.42	39,770	80,680
EH-72	72.00	75.04	4.11 - 4.39	1.25	74.39	1.42	40,910	81,510
EH-75	75.00	78.07	4.11 - 4.39	1.25	77.39	1.42	43,830	85,230
EH-78	78.00	81.21	4.11 - 4.39	1.55	80.45	1.73	46,730	109,910
EH-80	80.00	83.22	4.37 - 4.62	1.55	82.49	1.73	48,700	112,730
EH-82	82.00	85.28	4.37 - 4.62	1.55	84.55	1.73	51,120	115,550
EH-85	85.00	88.38	4.62 - 4.88	1.55	87.65	1.73	55,060	119,780
EH-88	88.00	91.45	4.62 - 4.88	1.55	90.69	1.73	57,860	124,000
EH-90	90.00	93.58	4.88 - 5.13	1.55	92.79	1.73	61,370	126,820
EH-92	92.00	95.66	4.88 - 5.13	1.55	94.85	1.73	64,070	129,640
EH-95	95.00	98.69	4.88 - 5.13	1.55	97.85	1.73	66,160	133,870
EH-98	98.00	101.83	5.13 - 5.38	1.55	100.99	1.73	71,590	138,090
EH-100	100.00	103.83	5.13 - 5.38	1.55	102.99	1.73	73,050	140,910
EH-102	102.00	106.00	5.38 - 5.64	1.55	105.15	1.73	78,490	143,730
EH-105	105.00	109.00	5.38 - 5.64	1.55	108.15	1.73	80,800	147,960
EH-108	108.00	112.22	5.64 - 5.89	1.55	111.31	1.73	87,310	152,190
EH-110	110.00	114.25	5.64 - 5.89	1.55	113.31	1.73	62,140	155,000
EH-112	112.00	116.44	5.89 - 6.15	1.55	115.45	1.73	94,370	157,820
EH-115	115.00	119.44	5.89 - 6.15	1.55	118.45	1.73	96,890	162,050
EH-120	120.00	124.54	6.20 - 6.45	1.83	123.55	2.00	104,030	199,640
EH-125	125.00	129.59	6.20 - 6.45	1.83	128.55	2.00	108,360	207,960
EH-130	130.00	134.71	6.20 - 6.45	1.83	133.65	2.00	115,860	216,280
EH-135	135.00	139.74	6.20 - 6.45	1.83	138.62	2.00	119,000	224,600
EH-140	140.00	144.87	6.20 - 6.45	1.83	143.72	2.00	126,820	232,920
EH-145	145.00	150.04	6.20 - 6.45	1.83	148.82	2.00	134,880	241,230
EH-150	150.00	155.07	6.20 - 6.45	1.83	153.82	2.00	139,530	249,550
EH-155	155.00	160.72	7.72 - 8.03	2.18	159.40	2.40	166,080	307,190
EH-160	160.00	165.74	7.72 - 8.03	2.18	164.40	2.40	171,433	317,100
EH-165	165.00	170.77	7.72 - 8.03	2.18	169.40	2.40	176,790	327,010
EH-170	170.00	176.05	7.72 - 8.03	2.18	174.60	2.40	190,430	336,920
EH-175	175.00	181.05	7.72 - 8.03	2.18	179.60	2.40	196,030	346,830
EH-180	180.00	186.38	7.72 - 8.03	2.18	184.88	2.40	213,900	356,740
EH-185	185.00	191.10	7.72 - 8.03	2.18	189.88	2.40	219,840	366,650
EH-190	190.00	196.45	7.72 - 8.03	2.18	194.88	2.40	225,790	376,560
EH-195	195.00	201.74	7.72 - 8.03	2.18	200.14	2.40	244,070	386,460
EH-200	200.00	206.76	7.72 - 8.03	2.18	205.14	2.40	250,330	396,370
EH-210	210.00	217.10	9.32 - 9.63	2.18	215.40	2.40	276,140	416,490
EH-220	220.00	227.40	9.32 - 9.63	2.18	225.64	2.40	257,150	436,010
EH-230	230.00	237.73	9.32 - 9.63	2.18	235.90	2.40	330,450	455,830
EH-240	240.00	247.80	9.32 - 9.63	2.18	245.90	2.40	344,810	475,650
EH-250	250.00	258.10	9.32 - 9.63	2.18	256.16	2.40	375,010	495,470
EH-260	260.00	268.43	9.32 - 9.63	2.18	266.40	2.40	405,210	515,290
EH-270	270.00	278.50	9.32 - 9.63	2.18	276.40	2.40	420,790	535,100
EH-280	280.00	288.82	9.32 - 9.63	2.18	286.66	2.40	454,100	554,920

¹ Add suffix "-S02" for 302 stainless steel, "-S16" for 316 stainless steel.
² Based on a groove material yield strength of 310 N/mm² and a safety factor of 2.
³ Based on a safety factor of 3.
⁴ See pages 126-127 for How to Order.
⁵ Contact Smalley for details/information on how to order parts to be in compliance with this specification.

Stock Items available in carbon steel and 302 and 316 stainless steel.

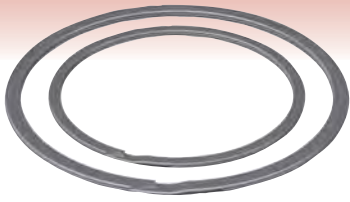

European Specification
Incorporating DIN 472

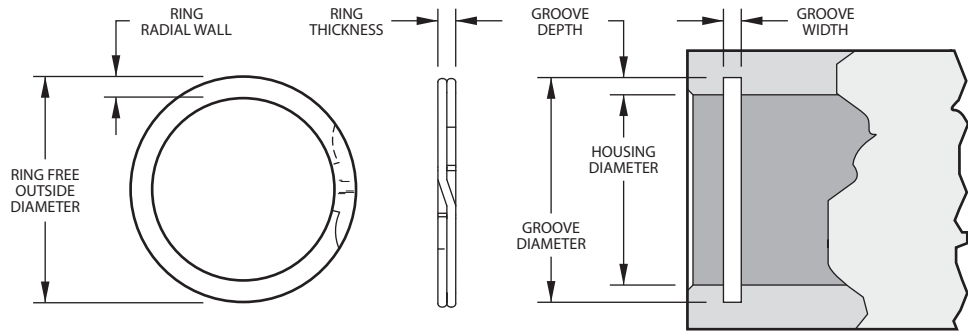

Product Dimensions All dimensions are in millimeters unless otherwise specified.

Smalley Part Number ^{1,4}	Housing Diameter	Ring			Groove		Thrust Capacity	
		Outside Diameter	Radial Wall	Thickness	Diameter	Width	Groove Yield (kN) ²	Ring Shear (kN) ³
DNH-13	13.00	13.72	1.40	.99	13.60	1.10	1,901	13,474
DNH-14	14.00	14.75	1.40	.99	14.60	1.10	2,047	14,510
DNH-15	15.00	15.85	1.40	.99	15.70	1.10	2,559	15,547
DNH-16	16.00	16.97	1.65	.99	16.80	1.10	3,119	16,583
DNH-17	17.00	17.98	1.65	.99	17.80	1.10	3,314	17,620
DNH-18	18.00	19.18	1.91	.99	19.00	1.10	4,386	18,656
DNH-19	19.00	20.19	1.91	.99	20.00	1.10	4,630	19,693
DNH-20	20.00	21.21	1.91	.99	21.00	1.10	4,874	20,729
DNH-21	21.00	22.23	1.91	.99	22.00	1.10	5,117	21,766
DNH-22	22.00	23.23	1.91	.99	23.00	1.10	5,361	22,802
DNH-23	23.00	24.33	2.18	1.14	24.10	1.30	6,165	23,853
DNH-24	24.00	25.45	2.18	1.14	25.20	1.30	7,018	24,891
DNH-25	25.00	26.45	2.18	1.14	26.20	1.30	7,310	25,928
DNH-26	26.00	27.48	2.18	1.14	27.20	1.30	7,603	26,965
DNH-27	27.00	28.68	2.41	1.14	28.40	1.30	9,211	28,002
DNH-28	28.00	29.69	2.41	1.14	29.40	1.30	9,552	29,039
DNH-29	29.00	30.71	2.41	1.14	30.40	1.30	9,893	30,076
DNH-30	30.00	31.71	2.41	1.14	31.40	1.30	10,235	31,113
DNH-31	31.00	33.02	2.41	1.14	32.70	1.30	12,842	32,150
DNH-32	32.00	34.04	2.41	1.14	33.70	1.30	13,256	33,187
DNH-33	33.00	35.05	2.41	1.14	34.70	1.30	13,670	34,224
DNH-34	34.00	36.07	3.25	1.44	35.70	1.60	14,085	44,541
DNH-35	35.00	37.38	3.25	1.44	37.00	1.60	17,058	45,851
DNH-36	36.00	38.39	3.25	1.44	38.00	1.60	17,545	47,161
DNH-37	37.00	39.40	3.25	1.44	39.00	1.60	18,032	48,471
DNH-38	38.00	40.41	3.25	1.44	40.00	1.60	18,520	49,781
DNH-40	40.00	42.93	4.01	1.69	42.50	1.85	24,368	61,498
DNH-41	41.00	43.94	4.01	1.69	43.50	1.85	24,977	63,036
DNH-42	42.00	44.96	4.01	1.69	44.50	1.85	25,586	64,573
DNH-45	45.00	47.98	4.01	1.69	47.50	1.85	27,414	69,186
DNH-47	47.00	49.99	4.01	1.69	49.50	1.85	28,633	72,261
DNH-48	48.00	51.00	4.01	1.69	50.50	1.85	29,242	73,798
DNH-50	50.00	53.54	5.08	1.93	53.00	2.15	36,552	87,790
DNH-51	51.00	54.54	5.08	1.93	54.00	2.15	37,283	89,546
DNH-52	52.00	55.55	5.08	1.93	55.00	2.15	38,014	91,302
DNH-55	55.00	58.57	5.08	1.93	58.00	2.15	40,207	96,569
DNH-56	56.00	59.59	5.08	1.93	59.00	2.15	40,938	98,325
DNH-57	57.00	60.60	5.08	1.93	60.00	2.15	41,669	100,081
DNH-58	58.00	61.62	5.08	1.93	61.00	2.15	42,400	101,836
DNH-60	60.00	63.63	5.08	1.93	63.00	2.15	43,863	105,348
DNH-62	62.00	65.66	5.08	1.93	65.00	2.15	45,325	108,860
DNH-63	63.00	66.67	5.08	1.93	66.00	2.15	46,056	110,615
DNH-64	64.00	67.67	5.08	1.93	67.00	2.15	46,787	112,371

1 Add suffix "-S02" for 302 stainless steel, "-S16" for 316 stainless steel.

2 Based on a groove material yield strength of 310 N/mm² and a safety factor of 2.

3 Based on a safety factor of 3.

4 See pages 126-127 for How to Order.

Smalley Part Number ^{1,4}	Housing Diameter	Ring			Groove		Thrust Capacity	
		Outside Diameter	Radial Wall	Thickness	Diameter	Width	Groove Yield (kN) ²	Ring Shear (kN) ³
DNH-65	65.00	68.67	5.08	2.41	68.00	2.65	47,518	135,725
DNH-67	67.00	70.67	5.08	2.41	70.00	2.65	48,980	139,901
DNH-68	68.00	71.67	5.08	2.41	71.00	2.65	49,711	141,989
DNH-70	70.00	73.67	5.08	2.41	73.00	2.65	51,173	146,165
DNH-72	72.00	75.67	5.08	2.41	75.00	2.65	52,635	150,341
DNH-75	75.00	78.68	5.08	2.41	78.00	2.65	54,828	156,605
DNH-76	76.00	79.68	5.08	2.41	79.00	2.65	55,559	158,694
DNH-78	78.00	81.69	5.08	2.41	81.00	2.65	57,021	162,870
DNH-80	80.00	84.19	6.05	2.41	83.50	2.65	68,231	167,046
DNH-82	82.00	86.20	6.05	2.41	85.50	2.65	69,936	171,222
DNH-85	85.00	89.20	6.05	2.91	88.50	3.15	72,495	214,309
DNH-88	88.00	92.21	6.05	2.91	91.50	3.15	75,054	221,873
DNH-90	90.00	94.21	6.05	2.91	93.50	3.15	76,759	226,915
DNH-92	92.00	96.22	6.05	2.91	95.50	3.15	78,465	231,958
DNH-95	95.00	99.24	6.05	2.91	98.50	3.15	81,024	239,522
DNH-98	98.00	102.26	6.05	2.91	101.50	3.15	83,583	247,086
DNH-100	100.00	104.29	6.05	2.91	103.50	3.15	85,288	252,128
DNH-102	102.00	106.79	6.73	3.89	106.00	4.15	99,422	343,778
DNH-105	105.00	109.79	6.73	3.89	109.00	4.15	102,346	353,889
DNH-108	108.00	112.80	6.73	3.89	112.00	4.15	105,270	364,000
DNH-110	110.00	114.83	6.73	3.89	114.00	4.15	107,220	370,741
DNH-112	112.00	116.84	6.73	3.89	116.00	4.15	109,169	377,482
DNH-115	115.00	119.86	6.73	3.89	119.00	4.15	112,093	387,593
DNH-120	120.00	124.92	6.73	3.89	124.00	4.15	116,967	404,445
DNH-125	125.00	129.97	6.73	3.89	129.00	4.15	121,840	421,297
DNH-127	127.00	131.97	6.73	3.89	131.00	4.15	123,790	428,038
DNH-130	130.00	135.00	6.73	3.89	134.00	4.15	126,714	438,149
DNH-135	135.00	140.03	6.73	3.89	139.00	4.15	131,588	455,001
DNH-140	140.00	145.11	6.73	3.89	144.00	4.15	136,461	471,852
DNH-145	145.00	150.11	6.73	3.89	149.00	4.15	141,335	488,704
DNH-150	150.00	156.13	7.92	3.89	155.00	4.15	182,761	505,556
DNH-155	155.00	161.19	7.92	3.89	160.00	4.15	188,853	522,408
DNH-160	160.00	166.22	7.92	3.89	165.00	4.15	194,945	539,260
DNH-165	165.00	171.27	7.92	3.89	170.00	4.15	201,037	556,112
DNH-170	170.00	176.33	7.92	3.89	175.00	4.15	207,129	572,964
DNH-175	175.00	181.36	7.92	3.89	180.00	4.15	213,221	589,815
DNH-180	180.00	186.39	7.92	3.89	185.00	4.15	219,313	606,667
DNH-185	185.00	191.44	7.92	3.89	190.00	4.15	225,405	623,519
DNH-190	190.00	196.47	7.92	3.89	195.00	4.15	231,497	640,371
DNH-195	195.00	201.52	7.92	3.89	200.00	4.15	237,589	657,223
DNH-200	200.00	206.58	7.92	3.89	205.00	4.15	243,681	674,075
DNH-210	210.00	217.58	9.53	4.86	216.00	5.15	307,038	884,268
DNH-220	220.00	227.66	9.53	4.86	226.00	5.15	321,659	926,376
DNH-230	230.00	237.72	9.53	4.86	236.00	5.15	336,280	968,484
DNH-240	240.00	247.80	9.53	4.86	246.00	5.15	350,900	1,010,592
DNH-250	250.00	257.89	9.53	4.86	256.00	5.15	365,521	1,052,700
DNH-260	260.00	269.93	11.18	4.86	268.00	5.15	506,856	1,094,808
DNH-270	270.00	280.01	11.18	4.86	278.00	5.15	526,351	1,136,916
DNH-280	280.00	290.09	11.18	4.86	288.00	5.15	545,845	1,179,024
DNH-290	290.00	300.15	11.18	4.86	298.00	5.15	565,340	1,221,132
DNH-300	300.00	310.24	11.18	4.86	308.00	5.15	584,834	1,263,241
DNH-310	310.00	322.25	12.70	5.87	320.00	6.20	755,411	1,576,625
DNH-320	320.00	332.33	12.70	5.87	330.00	6.20	779,779	1,627,484
DNH-330	330.00	342.42	12.70	5.87	340.00	6.20	804,147	1,678,342
DNH-340	340.00	352.50	12.70	5.87	350.00	6.20	828,515	1,729,201
DNH-350	350.00	362.56	12.70	5.87	360.00	6.20	852,883	1,780,060
DNH-360	360.00	372.64	12.70	5.87	370.00	6.20	877,251	1,830,919
DNH-370	370.00	382.73	12.70	5.87	380.00	6.20	901,619	1,881,778
DNH-380	380.00	392.79	12.70	5.87	390.00	6.20	925,987	1,932,637
DNH-390	390.00	402.84	12.70	5.87	400.00	6.20	950,355	1,983,496
DNH-400	400.00	412.93	12.70	5.87	410.00	6.20	974,723	2,034,354

1 Add suffix "-S02" for 302 stainless steel, "-S16" for 316 stainless steel.
2 Based on a groove material yield strength of 310 N/mm² and a safety factor of 2.
3 Based on a safety factor of 3.
4 See pages 126-127 for How to Order.

Stock Items available in carbon steel and 302 stainless steel.



Groove Compatible with DIN 472

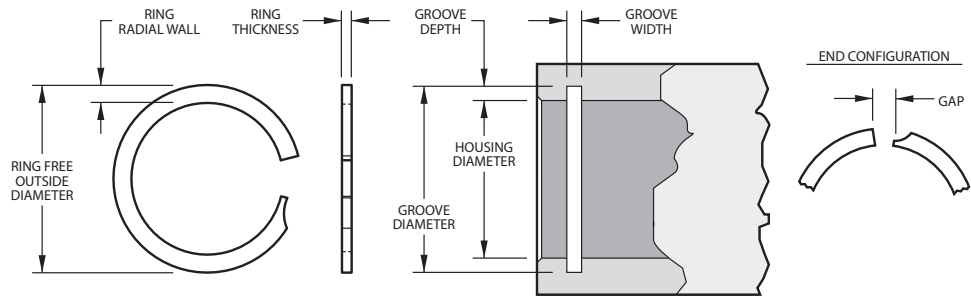

Product Dimensions All dimensions are in millimeters unless otherwise specified.

Smalley Part Number ^{1,4}	Housing Diameter	Ring			Groove		Thrust Capacity	
		Outside Diameter	Radial Wall	Thickness	Diameter	Width	Groove Yield (kN) ²	Ring Shear (kN) ³
FH-013	13.00	13.73	1.40	.94	13.60	1.10	1,931	10,591
FH-014	14.00	14.74	1.40	.94	14.60	1.10	2,077	11,396
FH-015	15.00	15.85	1.40	.94	15.70	1.10	2,602	12,224
FH-016	16.00	16.90	1.65	.94	16.80	1.10	3,172	13,029
FH-017	17.00	17.97	1.65	.94	17.80	1.10	3,367	13,838
FH-018	18.00	19.18	1.90	.94	19.00	1.10	4,457	14,666
FH-019	19.00	20.25	1.90	.94	20.00	1.10	4,702	15,471
FH-020	20.00	21.20	1.90	.94	21.00	1.10	4,951	16,276
FH-021	21.00	22.21	1.90	.94	22.00	1.10	5,200	17,103
FH-022	22.00	23.22	1.90	.94	23.00	1.10	5,445	17,913
FH-023	23.00	24.23	1.90	.94	24.00	1.10	5,698	18,736
FH-024	24.00	25.40	2.15	1.15	25.20	1.30	6,539	23,927
FH-025	25.00	26.45	2.15	1.15	26.20	1.30	6,806	24,914
FH-026	26.00	27.46	2.15	1.15	27.20	1.30	7,082	25,929
FH-027	27.00	28.47	2.38	1.15	28.20	1.30	7,353	26,916
FH-028	28.00	29.68	2.38	1.15	29.40	1.30	9,702	27,904
FH-029	29.00	30.69	2.38	1.15	30.40	1.30	10,053	28,918
FH-030	30.00	31.79	2.38	1.15	31.40	1.30	10,395	29,905
FH-031	31.00	33.01	2.38	1.15	32.70	1.30	12,660	30,893
FH-032	32.00	33.93	2.38	1.15	33.70	1.30	13,073	31,907
FH-033	33.00	35.03	2.38	1.15	34.70	1.30	13,478	32,895
FH-034	34.00	36.04	3.25	1.44	35.70	1.60	13,892	40,319
FH-035	35.00	37.35	3.25	1.44	37.00	1.60	16,899	41,493
FH-036	36.00	38.36	3.25	1.44	38.00	1.60	17,375	42,663
FH-037	37.00	39.37	3.25	1.44	39.00	1.60	17,869	43,868
FH-038	38.00	40.44	3.25	1.44	40.00	1.60	18,344	45,043
FH-040	40.00	42.86	4.01	1.69	42.50	1.85	24,265	55,621
FH-041	41.00	43.91	4.01	1.69	43.50	1.85	24,866	56,995
FH-042	42.00	44.92	4.01	1.69	44.50	1.85	25,484	58,410
FH-045	45.00	47.88	4.01	1.69	47.50	1.85	27,303	62,578
FH-047	47.00	49.97	4.01	1.69	49.50	1.85	28,504	65,331
FH-048	48.00	50.98	4.01	1.69	50.50	1.85	29,118	66,741
FH-050	50.00	53.50	5.08	1.93	53.00	2.15	36,529	75,282
FH-051	51.00	54.43	5.08	1.93	54.00	2.15	37,249	76,776
FH-052	52.00	55.52	5.08	1.93	55.00	2.15	37,974	78,266
FH-055	55.00	58.55	5.08	1.93	58.00	2.15	40,163	82,777
FH-056	56.00	59.56	5.08	1.93	59.00	2.15	40,906	84,307
FH-057	57.00	60.68	5.08	1.93	60.00	2.15	41,631	85,797
FH-058	58.00	61.58	5.08	1.93	61.00	2.15	42,352	87,287
FH-060	60.00	63.60	5.08	1.93	63.00	2.15	43,819	90,308
FH-062	62.00	65.58	5.08	1.93	65.00	2.15	45,283	93,328
FH-063	63.00	66.63	5.08	1.93	66.00	2.15	46,008	94,823
FH-064	64.00	67.64	5.08	2.41	67.00	2.65	46,751	114,742

¹ Add suffix "-S02" for 302 stainless steel.

² Based on a groove material yield strength of 310 N/mm² and a safety factor of 2.

³ Based on a safety factor of 3.

⁴ See pages 126-127 for How to Order.

Smalley Part Number ^{1,4}	Housing Diameter	Ring			Groove		Thrust Capacity	
		Outside Diameter	Radial Wall	Thickness	Diameter	Width	Groove Yield (kN) ²	Ring Shear (kN) ³
FH-065	65.00	68.70	5.08	2.41	68.00	2.65	47,471	116,517
FH-067	67.00	70.54	5.08	2.41	70.00	2.65	48,939	120,115
FH-068	68.00	71.84	5.08	2.41	71.00	2.65	49,660	121,890
FH-070	70.00	73.64	5.08	2.41	73.00	2.65	51,128	125,489
FH-072	72.00	75.72	5.08	2.41	75.00	2.65	52,591	129,083
FH-075	75.00	78.75	5.08	2.41	78.00	2.65	54,780	134,456
FH-076	76.00	79.88	5.08	2.41	79.00	2.65	55,505	136,231
FH-078	78.00	81.73	5.08	2.41	81.00	2.65	56,968	139,830
FH-080	80.00	84.30	6.02	2.41	83.50	2.65	68,342	143,428
FH-082	82.00	86.32	6.02	2.41	85.50	2.65	70,033	146,978
FH-085	85.00	89.35	6.30	2.91	88.50	3.15	72,595	175,046
FH-088	88.00	92.38	6.30	2.91	91.50	3.15	75,175	181,269
FH-090	90.00	94.70	6.30	2.91	93.50	3.15	76,865	185,353
FH-092	92.00	96.50	6.30	2.91	95.50	3.15	78,582	189,485
FH-095	95.00	99.62	6.30	2.91	98.50	3.15	81,140	195,659
FH-098	98.00	102.71	6.30	2.91	101.50	3.15	83,702	201,829
FH-100	100.00	104.50	6.30	2.91	103.50	3.15	85,415	205,962
FH-102	102.00	107.27	6.73	3.89	106.00	4.15	87,127	269,224
FH-105	105.00	109.96	6.73	3.89	109.00	4.15	102,687	277,133
FH-108	108.00	113.09	6.73	3.89	112.00	4.15	105,619	285,042
FH-110	110.00	115.10	6.73	3.89	114.00	4.15	107,580	290,340
FH-112	112.00	117.12	6.73	3.89	116.00	4.15	109,520	295,567
FH-115	115.00	120.15	6.73	3.89	119.00	4.15	112,473	303,547
FH-120	120.00	125.60	6.73	3.89	124.00	4.15	117,344	316,687
FH-125	125.00	130.25	6.73	3.89	129.00	4.15	122,237	329,893
FH-127	127.00	132.27	6.73	3.89	131.00	4.15	124,199	335,187
FH-130	130.00	135.30	6.73	3.89	134.00	4.15	127,130	343,096
FH-135	135.00	140.35	6.73	3.89	139.00	4.15	132,023	356,303
FH-140	140.00	145.26	6.73	3.89	144.00	4.15	136,916	369,509
FH-145	145.00	150.45	6.73	3.89	149.00	4.15	141,809	382,716
FH-150	150.00	156.50	8.03	3.89	155.00	4.15	181,986	395,923
FH-155	155.00	161.55	8.03	3.89	160.00	4.15	188,026	409,063
FH-160	160.00	166.60	8.03	3.89	165.00	4.15	194,094	422,270
FH-165	165.00	171.70	8.03	3.89	170.00	4.15	200,166	435,476
FH-170	170.00	176.70	8.03	3.89	175.00	4.15	206,237	448,683
FH-175	175.00	181.75	8.03	3.89	180.00	4.15	212,305	461,890
FH-180	180.00	186.80	8.03	3.89	185.00	4.15	218,377	475,097
FH-185	185.00	191.85	8.03	3.89	190.00	4.15	224,417	488,232
FH-190	190.00	197.15	8.03	3.89	195.00	4.15	230,489	501,439
FH-195	195.00	201.95	8.03	3.89	200.00	4.15	236,556	514,646
FH-200	200.00	207.00	8.03	3.89	205.00	4.15	242,628	527,853
FH-210	210.00	217.93	9.48	4.87	216.00	5.15	306,763	657,096
FH-220	220.00	228.20	9.48	4.87	226.00	5.15	321,344	688,327
FH-230	230.00	238.30	9.48	4.87	236.00	5.15	335,961	719,638
FH-240	240.00	248.40	9.48	4.87	246.00	5.15	350,578	750,953
FH-250	250.00	258.50	9.48	4.87	256.00	5.15	365,199	782,264
FH-260	260.00	270.77	11.05	4.87	268.00	5.15	505,300	813,500
FH-270	270.00	280.70	11.05	4.87	278.00	5.15	524,748	844,811
FH-280	280.00	290.57	11.05	4.87	288.00	5.15	544,200	876,126
FH-290	290.00	300.90	11.05	4.87	298.00	5.15	563,599	907,357
FH-300	300.00	311.00	11.05	4.87	308.00	5.15	583,051	938,673

¹ Add suffix "-S02" for 302 stainless steel.

² Based on a groove material yield strength of 310 N/mm² and a safety factor of 2.

³ Based on a safety factor of 3.

⁴ See pages 126-127 for How to Order.

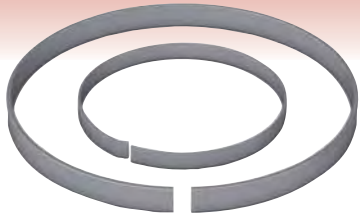

Stock Items available in carbon steel and 302 stainless steel.

Product Dimensions

All dimensions in inches unless otherwise specified.

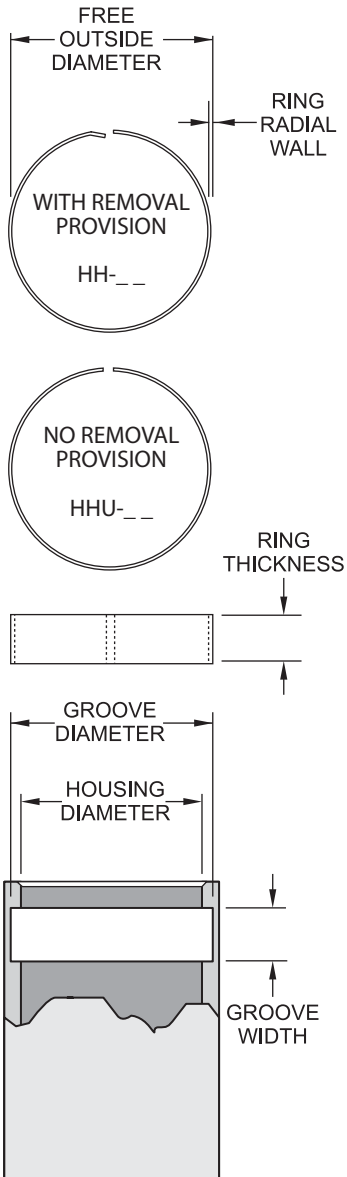

Internal Hoopster Retaining Rings are difficult to remove from the groove without a removal provision. We offer either a bent end for removal or no removal provision as shown to the left.

Smalley Part Number ^{1,2,4}	Housing Diameter	Ring			Groove		Groove Yield (lb) ³
		Outside Diameter	Radial Wall	Thickness	Diameter	Width	
HH-37	.375	.400	.017	.045	.392	.050	225
HH-43	.437	.463	.017	.045	.454	.050	263
HH-46	.469	.495	.017	.045	.486	.050	282
HH-50	.500	.531	.021	.065	.521	.070	371
HH-53	.531	.563	.021	.065	.552	.070	394
HH-56	.562	.594	.021	.065	.583	.070	417
HH-59	.594	.627	.021	.065	.615	.070	441
HH-62	.625	.659	.021	.065	.646	.070	464
HH-65	.656	.690	.021	.065	.677	.070	487
HH-68	.688	.723	.021	.065	.709	.070	511
HH-71	.718	.756	.024	.088	.742	.093	609
HH-75	.750	.789	.024	.088	.774	.093	636
HH-78	.781	.821	.024	.088	.805	.093	662
HH-81	.812	.852	.024	.088	.836	.093	689
HH-84	.843	.884	.024	.088	.867	.093	715
HH-87	.875	.917	.024	.088	.899	.093	742
HH-90	.906	.948	.024	.088	.930	.093	768
HH-93	.938	.981	.024	.088	.962	.093	796
HH-96	.968	1.011	.024	.088	.992	.093	821
HH-100	1.000	1.044	.024	.088	1.024	.093	848
HH-103	1.031	1.082	.030	.118	1.061	.123	1,093
HH-106	1.062	1.113	.030	.118	1.092	.123	1,126
HH-109	1.093	1.145	.030	.118	1.123	.123	1,159
HH-112	1.125	1.178	.030	.118	1.155	.123	1,193
HH-115	1.156	1.209	.030	.118	1.186	.123	1,226
HH-118	1.188	1.242	.030	.118	1.218	.123	1,260
HH-121	1.218	1.272	.030	.118	1.248	.123	1,291
HH-125	1.250	1.305	.030	.118	1.280	.123	1,325
HH-128	1.281	1.337	.030	.118	1.311	.123	1,358
HH-131	1.312	1.372	.034	.150	1.346	.155	1,577
HH-134	1.343	1.404	.034	.150	1.377	.155	1,614
HH-137	1.375	1.437	.034	.150	1.409	.155	1,652
HH-140	1.406	1.468	.034	.150	1.440	.155	1,690
HH-143	1.437	1.500	.034	.150	1.471	.155	1,727
HH-146	1.468	1.531	.034	.150	1.502	.155	1,765
HH-150	1.500	1.564	.034	.150	1.534	.155	1,802
HH-156	1.562	1.627	.034	.150	1.596	.155	1,877
HH-162	1.625	1.692	.034	.150	1.659	.155	1,953
HH-168	1.688	1.755	.034	.150	1.721	.155	2,028
HH-175	1.750	1.823	.038	.187	1.788	.193	2,350
HH-181	1.812	1.887	.038	.187	1.851	.193	2,434
HH-187	1.875	1.951	.038	.187	1.913	.193	2,518
HH-193	1.938	2.015	.038	.187	1.976	.193	2,603
HH-200	2.000	2.078	.038	.187	2.038	.193	2,686
HH-206	2.062	2.141	.038	.187	2.100	.193	2,769
HH-212	2.125	2.206	.038	.187	2.163	.193	2,854
HH-218	2.188	2.270	.038	.187	2.226	.193	2,939
HH-225	2.250	2.333	.038	.187	2.288	.193	3,022
HH-231	2.312	2.396	.038	.187	2.350	.193	3,105
HH-237	2.375	2.461	.038	.187	2.413	.193	3,190
HH-243	2.437	2.531	.045	.225	2.482	.232	3,876
HH-250	2.500	2.595	.045	.225	2.545	.232	3,976
HH-256	2.562	2.658	.045	.225	2.607	.232	4,075
HH-262	2.625	2.723	.045	.225	2.670	.232	4,175
HH-268	2.688	2.787	.045	.225	2.733	.232	4,275
HH-275	2.750	2.850	.045	.225	2.795	.232	4,374
HH-281	2.812	2.914	.045	.225	2.858	.232	4,472
HH-287	2.875	2.978	.045	.225	2.920	.232	4,572
HH-293	2.938	3.041	.045	.225	2.982	.232	4,673
HH-300	3.000	3.105	.045	.225	3.045	.232	4,771

¹ Use "HH" prefix for removal provision end. Use "HHU" prefix for no removal provision.

² Add suffix "-S02" for 302 stainless steel.

³ Based on a groove material yield strength of 45,000 psi and a safety factor of 2.

⁴ See pages 126-127 for How to Order.

Stock Items available in carbon steel and 302 stainless steel.

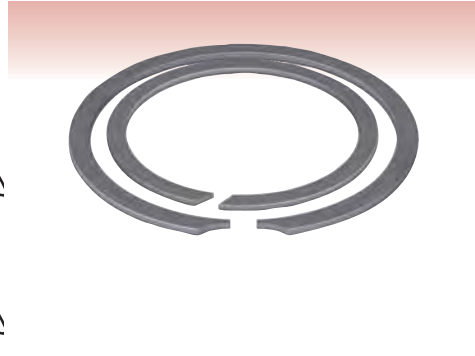
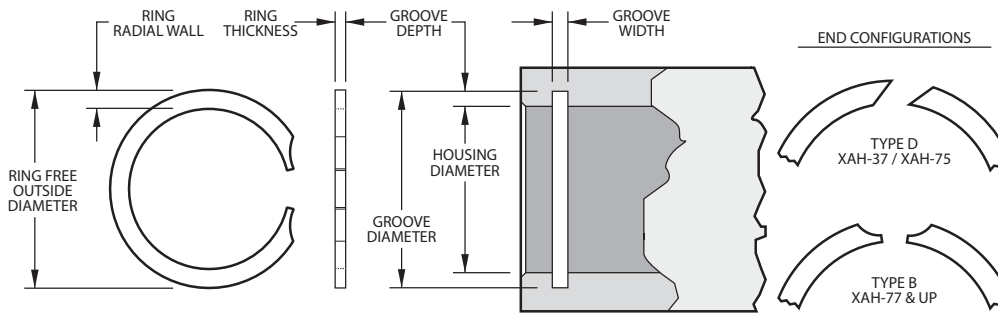

Product Dimensions All dimensions are in inches unless otherwise specified.

Smalley Part Number ^{1,4}	Housing Diameter	Ring			Groove		Thrust Capacity	
		Outside Diameter	Radial Wall	Thickness	Diameter	Width	Groove Yield (lb) ²	Ring Shear (lb) ³
XAH-37	.375	.400	.035	.025	.395	.028	265	1,174
XAH-43	.438	.467	.035	.025	.462	.028	372	1,371
XAH-50	.500	.530	.040	.035	.524	.039	424	2,073
XAH-51	.512	.542	.040	.035	.536	.039	434	2,123
XAH-56	.562	.600	.048	.035	.590	.039	556	2,331
XAH-62	.625	.670	.048	.035	.657	.039	707	2,592
XAH-68	.688	.733	.048	.035	.720	.039	778	2,853
XAH-75	.750	.799	.048	.035	.786	.039	954	3,110
XAH-77	.777	.827	.062	.042	.813	.046	989	3,906
XAH-81	.812	.867	.062	.042	.852	.046	1,148	4,082
XAH-87	.875	.934	.062	.042	.919	.046	1,361	4,398
XAH-90	.901	.961	.078	.042	.945	.046	1,401	4,529
XAH-93	.938	1.003	.078	.042	.986	.046	1,591	4,715
XAH-100	1.000	1.070	.078	.042	1.052	.046	1,696	5,027
XAH-102	1.023	1.094	.093	.042	1.075	.046	1,880	5,142
XAH-106	1.062	1.134	.093	.050	1.114	.056	1,952	6,272
XAH-112	1.125	1.202	.093	.050	1.181	.056	2,227	6,644
XAH-118	1.188	1.270	.093	.050	1.248	.056	2,519	7,017
XAH-125	1.250	1.337	.109	.050	1.314	.056	2,827	7,383
XAH-131	1.312	1.404	.109	.050	1.380	.056	3,153	7,749
XAH-137	1.375	1.472	.109	.050	1.447	.056	3,499	8,121
XAH-143	1.438	1.535	.125	.050	1.510	.056	3,659	8,493
XAH-145	1.456	1.557	.125	.050	1.532	.056	3,911	8,599
XAH-150	1.500	1.607	.125	.050	1.576	.056	4,029	8,859
XAH-156	1.562	1.668	.125	.062	1.642	.068	4,416	11,002
XAH-162	1.625	1.736	.141	.062	1.709	.068	4,824	11,446
XAH-165	1.653	1.765	.141	.062	1.737	.068	4,907	11,643
XAH-168	1.688	1.804	.156	.062	1.776	.068	5,250	11,889
XAH-175	1.750	1.870	.156	.062	1.842	.068	5,690	12,326
XAH-181	1.812	1.933	.156	.062	1.904	.068	5,892	12,763
XAH-185	1.850	1.975	.156	.062	1.946	.068	6,277	13,030
XAH-187	1.875	2.000	.156	.062	1.971	.068	6,362	13,206
XAH-193	1.938	2.068	.156	.062	2.038	.068	6,849	13,650
XAH-196	1.968	2.098	.156	.062	2.068	.068	6,955	13,862
XAH-200	2.000	2.131	.156	.062	2.100	.068	7,069	14,087
XAH-206	2.062	2.197	.156	.078	2.166	.086	7,579	17,491
XAH-212	2.125	2.260	.156	.078	2.229	.086	7,811	18,025
XAH-218	2.188	2.331	.171	.078	2.296	.086	8,352	18,559
XAH-225	2.250	2.393	.171	.078	2.358	.086	8,588	19,085
XAH-231	2.312	2.459	.171	.078	2.424	.086	9,152	19,611
XAH-237	2.375	2.523	.171	.078	2.487	.086	9,401	20,145
XAH-244	2.440	2.592	.187	.078	2.556	.086	10,003	20,697
XAH-250	2.500	2.653	.187	.078	2.616	.086	10,249	21,206
XAH-253	2.531	2.688	.187	.078	2.651	.086	10,734	21,469
XAH-256	2.562	2.726	.187	.093	2.686	.103	11,228	26,078
XAH-262	2.625	2.790	.187	.093	2.750	.103	11,504	26,719
XAH-268	2.688	2.856	.187	.093	2.816	.103	11,780	27,361
XAH-271	2.717	2.882	.187	.093	2.842	.103	12,291	27,656

¹ Add suffix "-S02" for 302 stainless steel.

² Based on a groove material yield strength of 45,000 psi and a safety factor of 2.

³ Based on a safety factor of 3.

⁴ See pages 126-127 for How to Order.

XAH Series

Constant Section Rings

Stock Items available in carbon steel and 302 stainless steel.

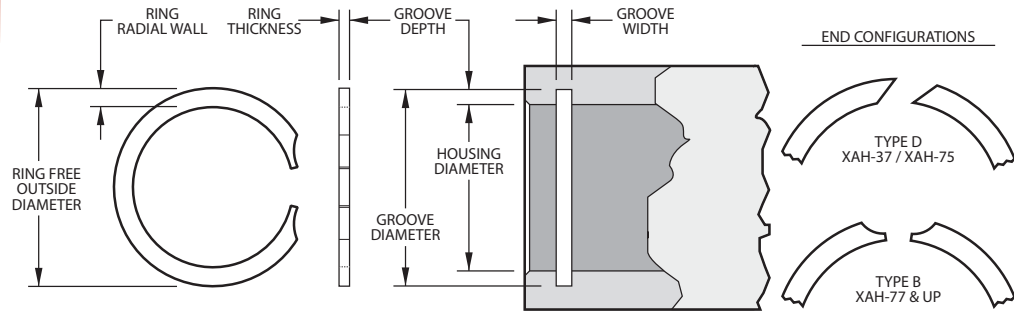
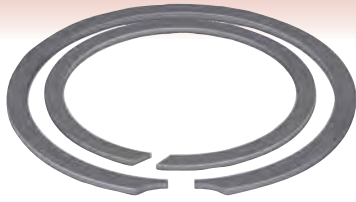

Product Dimensions All dimensions are in inches unless otherwise specified.

Smalley Part Number ^{1,4}	Housing Diameter	Ring			Groove		Thrust Capacity	
		Outside Diameter	Radial Wall	Thickness	Diameter	Width	Groove Yield (lb) ²	Ring Shear (lb) ³
XAH-275	2.750	2.918	.187	.093	2.878	.103	12,441	27,992
XAH-281	2.813	2.985	.187	.093	2.945	.103	13,123	28,633
XAH-283	2.834	3.006	.187	.093	2.966	.103	13,221	28,847
XAH-287	2.875	3.056	.187	.093	3.011	.103	13,819	29,264
XAH-300	3.000	3.181	.187	.093	3.136	.103	14,420	30,536
XAH-306	3.062	3.247	.218	.109	3.202	.120	15,151	35,009
XAH-312	3.125	3.311	.218	.109	3.265	.120	15,463	35,729
XAH-315	3.156	3.342	.218	.109	3.296	.120	15,616	36,084
XAH-325	3.250	3.442	.218	.109	3.394	.120	16,540	37,158
XAH-334	3.346	3.539	.218	.109	3.490	.120	17,029	38,256
XAH-346	3.469	3.663	.218	.109	3.613	.120	17,655	39,662
XAH-350	3.500	3.700	.250	.109	3.648	.120	18,308	40,017
XAH-354	3.543	3.745	.250	.109	3.691	.120	18,533	40,508
XAH-356	3.562	3.766	.250	.109	3.710	.120	18,632	40,725
XAH-362	3.625	3.831	.250	.109	3.773	.120	18,961	41,446
XAH-375	3.750	3.962	.250	.109	3.902	.120	20,145	42,875
XAH-387	3.875	4.089	.250	.109	4.027	.120	20,817	44,304
XAH-393	3.938	4.156	.250	.109	4.094	.120	21,712	45,024
XAH-400	4.000	4.221	.250	.109	4.156	.120	22,054	45,733
XAH-412	4.125	4.355	.250	.109	4.285	.120	23,326	47,162
XAH-425	4.250	4.485	.250	.109	4.410	.120	24,033	48,592
XAH-433	4.330	4.565	.250	.109	4.490	.120	24,486	49,506
XAH-443	4.436	4.670	.250	.109	4.596	.120	25,085	50,718
XAH-450	4.500	4.744	.250	.109	4.664	.120	26,083	51,450
XAH-462	4.625	4.875	.250	.109	4.795	.120	27,788	52,879
XAH-475	4.750	5.011	.281	.109	4.926	.120	29,547	54,308
XAH-500	5.000	5.265	.281	.109	5.180	.120	31,809	57,167
XAH-525	5.250	5.530	.312	.125	5.435	.139	34,141	65,732
XAH-537	5.375	5.660	.312	.125	5.565	.139	36,094	67,297
XAH-550	5.500	5.796	.312	.125	5.696	.139	38,100	68,862
XAH-575	5.750	6.050	.312	.125	5.950	.139	40,644	71,992
XAH-600	6.000	6.309	.312	.125	6.204	.139	43,260	75,122
XAH-625	6.250	6.568	.343	.156	6.458	.174	45,946	94,130
XAH-650	6.500	6.832	.343	.156	6.712	.174	48,703	97,895
XAH-662	6.625	6.975	.343	.156	6.845	.174	51,512	99,778
XAH-675	6.750	7.100	.343	.156	6.970	.174	52,484	101,660
XAH-700	7.000	7.350	.343	.156	7.220	.174	54,428	105,426
XAH-725	7.250	7.630	.375	.187	7.500	.209	64,059	123,654
XAH-750	7.500	7.890	.375	.187	7.750	.209	66,268	127,918
XAH-800	8.000	8.400	.375	.187	8.250	.209	70,686	136,446
XAH-825	8.250	8.665	.437	.187	8.540	.209	84,558	141,478
XAH-850	8.500	8.915	.437	.187	8.790	.209	87,120	145,766
XAH-875	8.750	9.205	.500	.187	9.080	.209	102,053	150,053
XAH-900	9.000	9.455	.500	.187	9.330	.209	104,968	154,340
XAH-905	9.055	9.509	.500	.187	9.384	.209	105,610	155,283
XAH-950	9.500	9.955	.500	.187	9.830	.209	110,800	162,915
XAH-984	9.840	10.295	.500	.187	10.170	.209	114,766	168,745
XAH-1000	10.000	10.455	.500	.187	10.330	.209	116,632	171,489

¹ Add suffix "-S02" for 302 stainless steel.

² Based on a groove material yield strength of 45,000 psi and a safety factor of 2.

³ Based on a safety factor of 3.

⁴ See pages 126-127 for How to Order.

Stock Items available in carbon steel and 302 stainless steel.

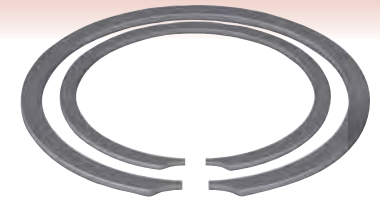
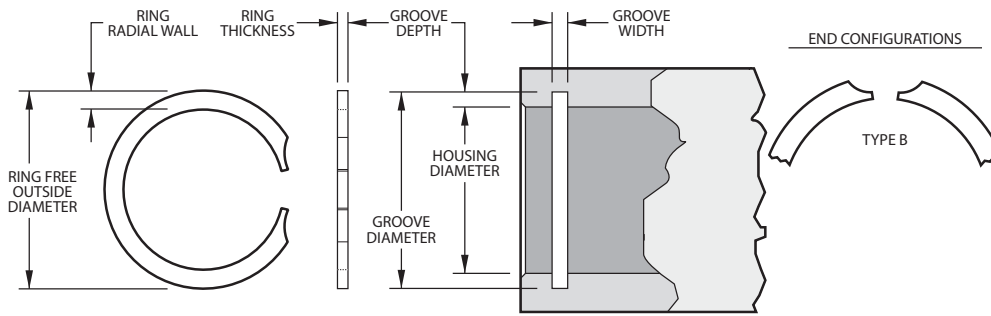

Product Dimensions All dimensions are in inches unless otherwise specified.

Smalley Part Number ^{1,4}	Housing Diameter	Ring			Groove		Thrust Capacity	
		Outside Diameter	Radial Wall	Thickness	Diameter	Width	Groove Yield (lb) ²	Ring Shear (lb) ³
XDH-112	1.125	1.196	.093	.042	1.181	.046	2,227	5,655
XDH-125	1.250	1.330	.093	.042	1.310	.046	2,651	6,283
XDH-137	1.375	1.460	.093	.042	1.435	.046	2,916	6,912
XDH-150	1.500	1.600	.125	.042	1.580	.046	4,241	7,540
XDH-162	1.625	1.725	.125	.042	1.705	.046	4,595	8,168
XDH-175	1.750	1.855	.125	.042	1.830	.046	4,948	8,796
XDH-187	1.875	1.990	.156	.042	1.965	.046	5,964	9,425
XDH-200	2.000	2.115	.156	.042	2.090	.046	6,362	10,053
XDH-206	2.062	2.177	.156	.042	2.152	.046	6,559	10,365
XDH-218	2.187	2.302	.156	.042	2.277	.046	6,957	10,993
XDH-231	2.312	2.432	.156	.042	2.402	.046	7,354	11,621
XDH-243	2.437	2.557	.156	.042	2.527	.046	7,752	12,250
XDH-256	2.562	2.682	.156	.042	2.652	.046	8,149	12,878
XDH-300	3.000	3.154	.187	.062	3.124	.068	13,148	21,130
XDH-325	3.250	3.404	.187	.062	3.374	.068	14,243	22,891
XDH-350	3.500	3.654	.187	.062	3.624	.068	15,339	24,652
XDH-375	3.750	3.904	.187	.062	3.874	.068	16,434	26,413
XDH-400	4.000	4.155	.187	.062	4.125	.068	17,671	28,174
XDH-425	4.250	4.429	.218	.078	4.394	.086	21,630	36,050
XDH-450	4.500	4.679	.218	.078	4.644	.086	22,902	38,170
XDH-475	4.750	4.929	.218	.078	4.894	.086	24,175	40,291
XDH-500	5.000	5.184	.218	.078	5.144	.086	25,447	42,412
XDH-525	5.250	5.434	.218	.078	5.394	.086	26,719	44,532
XDH-575	5.750	5.934	.218	.078	5.894	.086	29,264	48,773
XDH-600	6.000	6.220	.250	.093	6.160	.103	33,929	61,073
XDH-650	6.500	6.730	.250	.093	6.660	.103	36,757	66,162
XDH-700	7.000	7.240	.250	.093	7.160	.103	39,584	71,251
XDH-725	7.250	7.500	.250	.093	7.410	.103	40,998	73,796
XDH-750	7.500	7.760	.250	.093	7.660	.103	42,412	76,341
XDH-800	8.000	8.285	.250	.093	8.160	.103	45,239	81,430

¹ Add suffix "-S02" for 302 stainless steel.

² Based on a groove material yield strength of 45,000 psi and a safety factor of 2.

³ Based on a safety factor of 3.

⁴ See pages 126-127 for How to Order.

Stock Items available in carbon steel and 302 and 316 stainless steel.

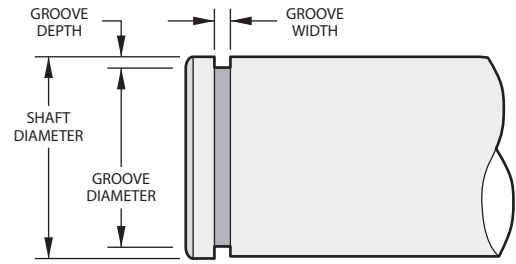
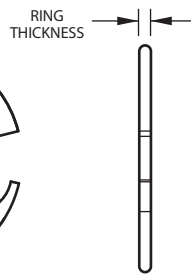
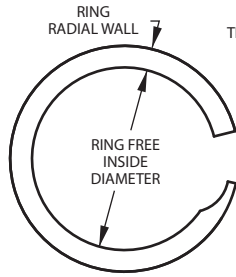
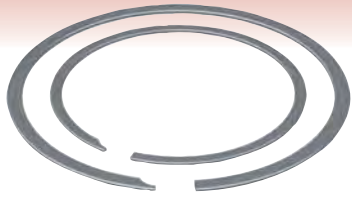

*No removal notch

Product Dimensions All dimensions are in inches unless otherwise specified.

Smalley Part Number ^{1,4}	Shaft Diameter	Ring			Groove		Thrust Capacity	
		Inside Diameter	Radial Wall	Thickness	Diameter	Width	Groove Yield (lb) ²	Ring Shear (lb) ³
VS-25*	.250	.236	.020	.012	.238	.015	106	481
VS-31*	.312	.294	.025	.015	.297	.018	165	750
VS-37*	.375	.348	.025	.015	.351	.018	318	901
VS-43	.437	.410	.035	.015	.413	.018	371	1,050
VS-50	.500	.467	.045	.018	.472	.022	500	1,300
VS-56	.562	.529	.045	.018	.534	.022	560	1,460
VS-62	.625	.591	.045	.018	.597	.022	620	1,630
VS-68	.687	.652	.045	.018	.659	.022	680	1,790
VS-75	.750	.715	.045	.018	.722	.022	740	1,950
VS-81	.812	.762	.065	.021	.770	.026	1,210	2,460
VS-87	.875	.825	.065	.021	.833	.026	1,300	2,660
VS-93	.937	.886	.065	.021	.895	.026	1,390	2,840
VS-100	1.000	.949	.065	.021	.958	.026	1,480	3,040
VS-106	1.062	1.008	.088	.025	1.018	.031	1,650	3,500
VS-112	1.125	1.071	.088	.025	1.081	.031	1,750	3,710
VS-118	1.187	1.132	.088	.025	1.143	.031	1,850	3,920
VS-125	1.250	1.194	.088	.025	1.206	.031	1,940	4,120
VS-131	1.312	1.255	.088	.025	1.268	.031	2,040	4,330
VS-137	1.375	1.318	.088	.025	1.331	.031	2,140	4,540
VS-143	1.437	1.379	.088	.025	1.393	.031	2,240	4,740
VS-150	1.500	1.442	.088	.025	1.456	.031	2,330	4,950
VS-156	1.562	1.488	.118	.031	1.505	.039	3,200	6,390
VS-162	1.625	1.550	.118	.031	1.568	.039	3,330	6,650
VS-168	1.687	1.612	.118	.031	1.630	.039	3,460	6,900
VS-175	1.750	1.674	.118	.031	1.693	.039	3,590	7,160
VS-181	1.812	1.736	.118	.031	1.755	.039	3,710	7,410
VS-187	1.875	1.798	.118	.031	1.818	.039	3,840	7,670
VS-193	1.937	1.859	.118	.031	1.880	.039	3,970	7,920
VS-200	2.000	1.922	.118	.031	1.943	.039	4,100	8,180
VS-206	2.062	1.963	.158	.031	1.986	.039	5,540	8,430
VS-212	2.125	2.026	.158	.031	2.049	.039	5,710	8,690
VS-218	2.187	2.087	.158	.031	2.111	.039	5,870	8,950
VS-225	2.250	2.149	.158	.031	2.174	.039	6,040	9,200
VS-231	2.312	2.211	.158	.031	2.236	.039	6,210	9,460
VS-237	2.375	2.273	.158	.031	2.299	.039	6,380	9,720
VS-243	2.437	2.335	.158	.031	2.361	.039	6,550	9,970
VS-250	2.500	2.397	.158	.031	2.424	.039	6,720	10,230
VS-256	2.562	2.458	.158	.031	2.486	.039	6,880	10,480
VS-262	2.625	2.521	.158	.031	2.549	.039	7,050	10,740
VS-268	2.687	2.582	.158	.031	2.611	.039	7,220	10,990
VS-275	2.750	2.644	.158	.031	2.674	.039	7,390	11,250
VS-281	2.812	2.706	.158	.031	2.736	.039	7,550	11,500
VS-287	2.875	2.768	.158	.031	2.799	.039	7,720	11,760
VS-293	2.937	2.830	.158	.031	2.861	.039	7,890	12,010
VS-300	3.000	2.892	.158	.031	2.924	.039	8,060	12,270

¹ Add suffix "-S02" for 302 stainless steel, "-S16" for 316 stainless steel.

² Based on a groove material yield strength of 45,000 psi and a safety factor of 2.

³ Based on a safety factor of 3.

⁴ See pages 126-127 for How to Order.

Stock Items available in carbon steel and 302 and 316 stainless steel.

Product Dimensions All dimensions are in inches unless otherwise specified.

Smalley Part Number ^{1,4}	Shaft Diameter	Ring			Groove		Thrust Capacity	
		Inside Diameter	Radial Wall	Thickness	Diameter	Width	Groove Yield (lb) ²	Ring Shear (lb) ³
VS-306	3.062	2.938	.188	.039	2.970	.044	9,960	15,760
VS-312	3.125	3.001	.188	.039	3.033	.044	10,160	16,080
VS-318	3.187	3.062	.188	.039	3.095	.044	10,360	16,400
VS-325	3.250	3.125	.188	.039	3.158	.044	10,570	16,720
VS-331	3.312	3.186	.188	.039	3.220	.044	10,770	17,040
VS-337	3.375	3.248	.188	.039	3.283	.044	10,970	17,370
VS-343	3.437	3.310	.188	.039	3.345	.044	11,180	17,690
VS-350	3.500	3.372	.188	.039	3.408	.044	11,380	18,010
VS-356	3.562	3.433	.188	.039	3.470	.044	11,580	18,330
VS-362	3.625	3.496	.188	.039	3.533	.044	11,790	18,650
VS-368	3.687	3.557	.188	.039	3.595	.044	11,990	18,970
VS-375	3.750	3.620	.188	.039	3.658	.044	12,190	19,300
VS-381	3.812	3.681	.188	.039	3.720	.044	12,400	19,620
VS-387	3.875	3.743	.188	.039	3.783	.044	12,600	19,940
VS-393	3.937	3.805	.188	.039	3.845	.044	12,800	20,260
VS-400	4.000	3.867	.188	.039	3.908	.044	13,010	20,580
VS-412	4.125	3.973	.225	.046	4.015	.052	16,040	23,850
VS-425	4.250	4.097	.225	.046	4.140	.052	16,520	24,570
VS-437	4.375	4.221	.225	.046	4.265	.052	17,010	25,290
VS-450	4.500	4.345	.225	.046	4.390	.052	17,500	26,010
VS-462	4.625	4.468	.225	.046	4.515	.052	17,980	26,740
VS-475	4.750	4.592	.225	.046	4.640	.052	18,470	27,460
VS-487	4.875	4.715	.225	.046	4.765	.052	18,950	28,180
VS-500	5.000	4.839	.225	.046	4.890	.052	19,440	28,900
VS-525	5.250	5.067	.225	.061	5.119	.067	24,490	40,240
VS-550	5.500	5.309	.225	.061	5.363	.067	26,830	42,160
VS-575	5.750	5.550	.225	.061	5.606	.067	29,260	44,080
VS-600	6.000	5.792	.225	.061	5.850	.067	31,810	45,990
VS-625	6.250	6.033	.265	.061	6.094	.067	34,460	47,910
VS-650	6.500	6.275	.265	.061	6.338	.067	37,220	49,830
VS-675	6.750	6.515	.265	.061	6.581	.067	40,560	51,740
VS-700	7.000	6.757	.265	.061	6.825	.067	43,540	53,660
VS-725	7.250	6.998	.300	.061	7.069	.067	46,640	55,580
VS-750	7.500	7.240	.300	.061	7.313	.067	49,830	57,490
VS-775	7.750	7.480	.300	.061	7.556	.067	53,140	59,410
VS-800	8.000	7.722	.300	.061	7.800	.067	56,550	61,320
VS-825	8.250	7.964	.345	.076	8.044	.082	60,070	78,790
VS-850	8.500	8.205	.345	.076	8.288	.082	63,690	81,180
VS-875	8.750	8.446	.345	.076	8.531	.082	68,040	83,570
VS-900	9.000	8.687	.345	.076	8.775	.082	71,890	85,950
VS-925	9.250	8.929	.345	.076	9.019	.082	75,850	88,340
VS-950	9.500	9.170	.345	.076	9.263	.082	79,910	90,730
VS-975	9.750	9.411	.345	.076	9.506	.082	84,080	93,120
VS-1000	10.000	9.653	.345	.076	9.750	.082	88,360	95,500

¹ Add suffix "-S02" for 302 stainless steel, "-S16" for 316 stainless steel.

² Based on a groove material yield strength of 45,000 psi and a safety factor of 2.

³ Based on a safety factor of 3.

⁴ See pages 126-127 for How to Order.

Stock Items available in carbon steel and 302 and 316 stainless steel.

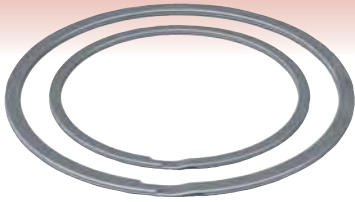

**AS3218, AS4299
MIL-DTL-27426/1**

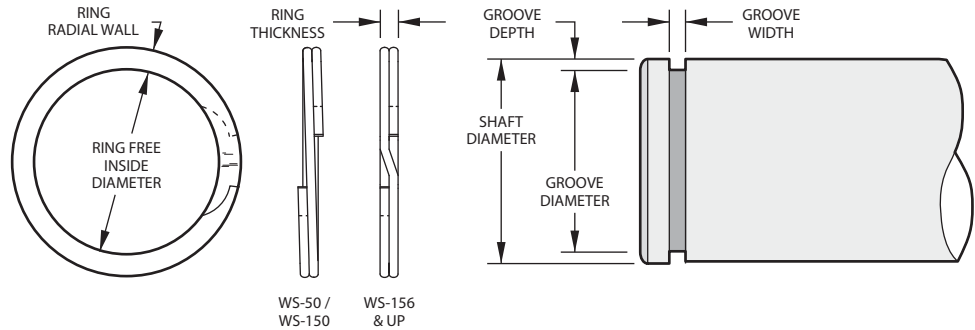

Product Dimensions All dimensions are in inches unless otherwise specified.

Smalley Part Number ^{1,4}	Shaft Diameter	Ring			Groove		Thrust Capacity	
		Inside Diameter	Radial Wall	Thickness	Diameter	Width	Groove Yield (lb) ²	Ring Shear (lb) ³
WS-50	.500	.467	.045	.025	.474	.030	460	2,000
WS-53	.531	.498	.045	.025	.505	.030	490	2,130
WS-55	.551	.518	.045	.025	.525	.030	510	2,210
WS-56	.562	.529	.045	.025	.536	.030	520	2,250
WS-59	.594	.561	.045	.025	.569	.030	550	2,380
WS-62	.625	.585	.055	.025	.594	.030	710	2,500
WS-65	.656	.617	.055	.025	.625	.030	740	2,630
WS-66	.669	.629	.055	.025	.638	.030	760	2,680
WS-68	.687	.647	.055	.025	.656	.030	780	2,750
WS-71	.718	.679	.055	.025	.687	.030	810	2,880
WS-75	.750	.710	.065	.031	.719	.036	850	3,360
WS-78	.781	.741	.065	.031	.750	.036	880	3,500
WS-81	.812	.771	.065	.031	.781	.036	920	3,640
WS-84	.843	.803	.065	.031	.812	.036	950	3,780
WS-87	.875	.828	.065	.031	.838	.036	1,180	3,920
WS-90	.906	.860	.065	.031	.869	.036	1,220	4,060
WS-93	.937	.889	.065	.031	.900	.036	1,260	4,200
WS-96	.968	.916	.075	.037	.925	.042	1,440	5,180
WS-98	.984	.930	.075	.037	.941	.042	1,460	5,260
WS-100	1.000	.946	.075	.037	.957	.042	1,480	5,350
WS-102	1.023	.968	.075	.037	.980	.042	1,520	5,470
WS-103	1.031	.978	.075	.037	.988	.042	1,530	5,510
WS-106	1.062	1.007	.075	.037	1.020	.042	1,580	5,680
WS-109	1.093	1.040	.075	.037	1.051	.042	1,620	5,840
WS-112	1.125	1.070	.075	.037	1.083	.042	1,670	6,020
WS-115	1.156	1.102	.075	.037	1.114	.042	1,720	6,180
WS-118	1.188	1.127	.085	.043	1.140	.048	2,020	7,380
WS-121	1.218	1.159	.085	.043	1.170	.048	2,070	7,570
WS-125	1.250	1.188	.085	.043	1.202	.048	2,120	7,770
WS-128	1.281	1.221	.085	.043	1.233	.048	2,170	7,960
WS-131	1.312	1.251	.095	.043	1.264	.048	2,230	8,150
WS-134	1.343	1.282	.095	.043	1.295	.048	2,280	8,350
WS-137	1.375	1.308	.095	.043	1.323	.048	2,530	8,540
WS-140	1.406	1.340	.095	.043	1.354	.048	2,580	8,740
WS-143	1.437	1.370	.095	.043	1.385	.048	2,640	8,930
WS-146	1.468	1.402	.095	.043	1.416	.048	2,700	9,120
WS-150	1.500	1.433	.095	.043	1.448	.048	2,760	9,320
WS-156	1.562	1.490	.108	.049	1.507	.056	3,090	10,100
WS-157	1.575	1.503	.108	.049	1.520	.056	3,120	10,190
WS-162	1.625	1.549	.108	.049	1.566	.056	3,450	10,510
WS-168	1.687	1.610	.118	.049	1.628	.056	3,580	10,910
WS-175	1.750	1.673	.118	.049	1.691	.056	3,710	11,310
WS-177	1.771	1.690	.118	.049	1.708	.056	4,010	11,450
WS-181	1.813	1.730	.118	.049	1.749	.056	4,100	11,720

¹ Add suffix "-S02" for 302 stainless steel, "-S16" for 316 stainless steel.

² Based on a groove material strength of 45,000 psi and a safety factor of 2.

³ Based on a safety factor of 3.

⁴ See pages 126-127 for How to Order.

Stock Items available in carbon steel and 302 and 316 stainless steel.

Product Dimensions All dimensions are in inches unless otherwise specified.

Smalley Part Number ^{1,4}	Shaft Diameter	Ring			Groove		Thrust Capacity	
		Inside Diameter	Radial Wall	Thickness	Diameter	Width	Groove Yield (lb) ²	Ring Shear (lb) ³
WS-187	1.875	1.789	.128	.049	1.808	.056	4,510	12,120
WS-193	1.938	1.844	.128	.049	1.861	.056	4,660	12,530
WS-196	1.969	1.882	.128	.049	1.902	.056	4,730	12,730
WS-200	2.000	1.909	.128	.049	1.929	.056	4,950	12,930
WS-206	2.062	1.971	.128	.049	1.992	.056	5,100	13,330
WS-212	2.125	2.029	.128	.049	2.051	.056	5,560	13,740
WS-215	2.156	2.060	.138	.049	2.082	.056	5,640	13,940
WS-216	2.165	2.070	.138	.049	2.091	.056	5,660	14,000
WS-218	2.188	2.092	.138	.049	2.113	.056	5,720	14,150
WS-225	2.250	2.153	.138	.049	2.176	.056	5,890	14,550
WS-231	2.312	2.211	.138	.049	2.234	.056	6,370	14,950
WS-236	2.362	2.261	.138	.049	2.284	.056	6,510	15,270
WS-237	2.375	2.273	.138	.049	2.297	.056	6,550	15,360
WS-243	2.437	2.331	.148	.049	2.355	.056	7,060	15,760
WS-250	2.500	2.394	.148	.049	2.418	.056	7,250	16,160
WS-255	2.559	2.449	.148	.049	2.473	.056	7,780	16,550
WS-256	2.562	2.452	.148	.049	2.476	.056	7,790	16,560
WS-262	2.625	2.514	.148	.049	2.539	.056	7,980	16,970
WS-268	2.688	2.572	.158	.049	2.597	.056	8,550	17,380
WS-275	2.750	2.635	.158	.049	2.660	.056	8,750	17,780
WS-281	2.813	2.696	.168	.049	2.722	.056	8,950	18,190
WS-287	2.875	2.755	.168	.049	2.781	.056	9,550	18,590
WS-293	2.937	2.817	.168	.049	2.843	.056	9,760	18,990
WS-295	2.952	2.831	.168	.049	2.858	.056	9,810	19,090
WS-300	3.000	2.877	.168	.061	2.904	.068	10,180	24,150
WS-306	3.062	2.938	.168	.061	2.966	.068	10,390	24,650
WS-312	3.125	3.000	.178	.061	3.027	.068	10,820	25,150
WS-314	3.149	3.023	.178	.061	3.051	.068	10,910	25,350
WS-318	3.187	3.061	.178	.061	3.089	.068	11,040	25,650
WS-325	3.250	3.121	.178	.061	3.150	.068	11,490	26,160
WS-331	3.312	3.180	.188	.061	3.208	.068	12,170	26,660
WS-334	3.343	3.210	.188	.061	3.239	.068	12,290	26,910
WS-337	3.375	3.242	.188	.061	3.271	.068	12,410	27,170
WS-343	3.437	3.301	.188	.061	3.331	.068	12,880	27,660
WS-350	3.500	3.363	.188	.061	3.394	.068	13,110	28,170
WS-354	3.543	3.402	.198	.061	3.433	.068	13,770	28,520
WS-356	3.562	3.422	.198	.061	3.452	.068	13,850	28,670
WS-362	3.625	3.483	.198	.061	3.515	.068	14,090	29,180
WS-368	3.687	3.543	.198	.061	3.575	.068	14,600	29,680
WS-374	3.740	3.597	.198	.061	3.628	.068	14,800	30,100
WS-375	3.750	3.606	.198	.061	3.638	.068	14,840	30,180
WS-381	3.812	3.668	.198	.061	3.700	.068	15,090	30,680
WS-387	3.875	3.724	.208	.061	3.757	.068	16,160	31,190
WS-393	3.938	3.784	.208	.061	3.820	.068	16,420	31,700
WS-400	4.000	3.842	.218	.061	3.876	.068	17,530	32,200
WS-406	4.063	3.906	.218	.061	3.939	.068	17,810	32,700
WS-412	4.125	3.967	.218	.061	4.000	.068	18,080	33,200
WS-413	4.134	3.975	.218	.061	4.010	.068	18,120	33,270
WS-418	4.188	4.030	.218	.061	4.058	.068	19,240	33,710
WS-425	4.250	4.084	.228	.061	4.120	.068	19,530	34,210
WS-431	4.312	4.147	.228	.061	4.182	.068	19,810	34,710
WS-433	4.331	4.164	.228	.061	4.200	.068	19,900	34,860
WS-437	4.375	4.208	.228	.061	4.245	.068	20,100	35,210
WS-443	4.437	4.271	.228	.061	4.307	.068	20,390	35,710
WS-450	4.500	4.326	.238	.061	4.364	.068	21,630	36,220
WS-456	4.562	4.384	.250	.072	4.422	.079	22,570	43,340
WS-462	4.625	4.447	.250	.072	4.485	.079	22,890	43,940
WS-468	4.687	4.508	.250	.072	4.547	.079	23,190	44,530
WS-472	4.724	4.546	.250	.072	4.584	.079	23,370	44,880
WS-475	4.750	4.571	.250	.072	4.610	.079	23,500	45,130
WS-481	4.812	4.633	.250	.072	4.672	.079	23,810	45,720
WS-487	4.875	4.695	.250	.072	4.735	.079	24,120	46,310

¹ Add suffix "-S02" for 302 stainless steel, "-S16" for 316 stainless steel.

² Based on a groove material yield strength of 45,000 psi and a safety factor of 2.

³ Based on a safety factor of 3.

⁴ See pages 126-127 for How to Order.

Stock Items available in carbon steel and 302 and 316 stainless steel.

Product Dimensions All dimensions are in inches unless otherwise specified.

Smalley Part Number ^{1,4}	Shaft Diameter	Ring			Groove		Thrust Capacity	
		Inside Diameter	Radial Wall	Thickness	Diameter	Width	Groove Yield (lb) ²	Ring Shear (lb) ³
WS-493	4.937	4.757	.250	.072	4.797	.079	24,430	46,900
WS-500	5.000	4.820	.250	.072	4.856	.079	25,450	47,500
WS-511	5.118	4.934	.250	.072	4.974	.079	26,050	48,620
WS-512	5.125	4.939	.250	.072	4.981	.079	26,080	48,690
WS-525	5.250	5.064	.250	.072	5.107	.079	26,720	49,880
WS-537	5.375	5.187	.250	.072	5.228	.079	28,120	51,060
WS-550	5.500	5.308	.250	.072	5.353	.079	28,770	52,250
WS-551	5.511	5.320	.250	.072	5.364	.079	28,830	52,360
WS-562	5.625	5.433	.250	.072	5.478	.079	29,420	53,440
WS-575	5.750	5.550	.250	.072	5.597	.079	31,300	54,630
WS-587	5.875	5.674	.250	.072	5.722	.079	31,980	55,810
WS-590	5.905	5.705	.250	.072	5.752	.079	32,140	56,100
WS-600	6.000	5.798	.250	.072	5.847	.079	32,660	57,000
WS-612	6.125	5.903	.312	.086	5.953	.094	37,230	69,500
WS-625	6.250	6.026	.312	.086	6.078	.094	37,990	70,920
WS-629	6.299	6.076	.312	.086	6.127	.094	38,290	71,480
WS-637	6.375	6.152	.312	.086	6.203	.094	38,750	72,340
WS-650	6.500	6.274	.312	.086	6.328	.094	39,510	73,760
WS-662	6.625	6.390	.312	.086	6.443	.094	42,620	75,180
WS-675	6.750	6.513	.312	.086	6.568	.094	43,420	76,600
WS-687	6.875	6.638	.312	.086	6.693	.094	44,220	78,010
WS-700	7.000	6.761	.312	.086	6.818	.094	45,030	79,430
WS-712	7.125	6.877	.312	.086	6.933	.094	48,350	80,850
WS-725	7.250	6.999	.312	.086	7.058	.094	49,200	82,270
WS-737	7.375	7.125	.312	.086	7.183	.094	50,050	83,690
WS-750	7.500	7.250	.312	.086	7.308	.094	50,890	85,110
WS-762	7.625	7.363	.312	.086	7.423	.094	54,440	86,520
WS-775	7.750	7.486	.312	.086	7.548	.094	55,330	87,940
WS-787	7.875	7.611	.312	.086	7.673	.094	56,220	89,360
WS-800	8.000	7.734	.312	.086	7.798	.094	57,110	90,780
WS-825	8.250	7.972	.375	.086	8.038	.094	61,820	93,620
WS-850	8.500	8.220	.375	.086	8.288	.094	63,690	96,450
WS-875	8.750	8.459	.375	.086	8.528	.094	68,650	99,290
WS-900	9.000	8.707	.375	.086	8.778	.094	70,620	102,130
WS-925	9.250	8.945	.375	.086	9.018	.094	75,850	104,960
WS-950	9.500	9.194	.375	.086	9.268	.094	77,900	107,800
WS-975	9.750	9.432	.375	.086	9.508	.094	83,390	110,640
WS-1000	10.000	9.680	.375	.086	9.758	.094	85,530	113,470
WS-1025	10.250	9.918	.375	.086	9.998	.094	91,290	116,310
WS-1050	10.500	10.166	.375	.086	10.248	.094	93,520	119,150
WS-1075	10.750	10.405	.375	.086	10.488	.094	99,540	121,990
WS-1100	11.000	10.653	.375	.086	10.738	.094	101,860	124,820

¹ Add suffix "-S02" for 302 stainless steel, "-S16" for 316 stainless steel.

² Based on a groove material yield strength of 45,000 psi and a safety factor of 2.

³ Based on a safety factor of 3.

⁴ See pages 126-127 for How to Order.

Stock Items available in carbon steel and 17-7 stainless steel.

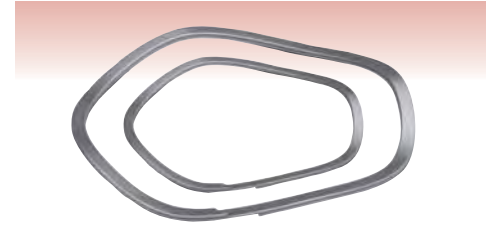
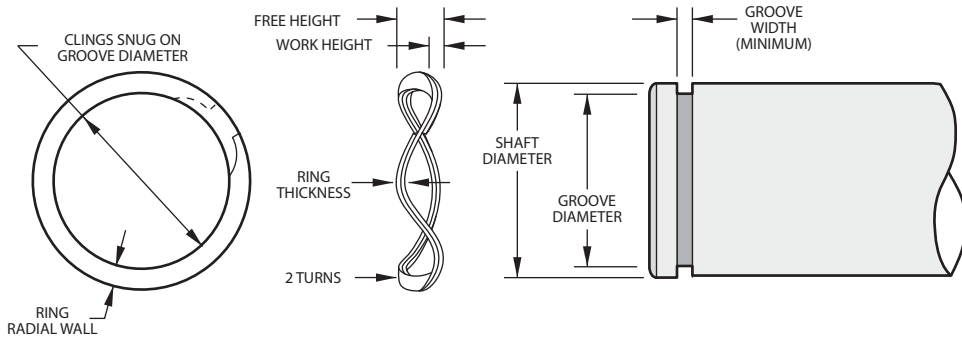

Product Dimensions All dimensions are in inches unless otherwise specified.

Smalley Part Number ^{1,2}	Shaft Diameter	Load (lb) @ Work Height	Max. Free Height	Number of Waves	Ring			Groove	
					Thickness	Radial Wall	Crimp	Diameter	Width Min.
WSW-75	.750	25 @ .085	.115	3	.042	.065	N	.704	.120
WSW-87	.875	30 @ .085	.131	3	.042	.075	N	.821	.136
WSW-100	1.000	34 @ .085	.129	3	.042	.085	N	.940	.134
WSW-112	1.125	38 @ .100	.137	3	.050	.128	N	1.059	.142
WSW-125	1.250	40 @ .100	.145	3	.050	.128	N	1.176	.150
WSW-137	1.375	45 @ .100	.130	4	.050	.128	N	1.291	.135
WSW-150	1.500	50 @ .100	.126	4	.050	.128	N	1.406	.131
WSW-162	1.625	55 @ .110	.138	4	.062	.158	N	1.529	.143
WSW-175	1.750	60 @ .110	.137	4	.062	.158	N	1.650	.142
WSW-187	1.875	63 @ .110	.140	4	.062	.158	N	1.769	.145
WSW-200	2.000	65 @ .110	.145	4	.062	.158	N	1.886	.150
WSW-212	2.125	70 @ .130	.170	4	.078	.188	N	2.003	.175
WSW-225	2.250	75 @ .130	.175	4	.078	.188	N	2.120	.180
WSW-237	2.375	80 @ .130	.175	4	.078	.188	N	2.239	.180
WSW-250	2.500	84 @ .130	.171	4	.078	.188	N	2.360	.176
WSW-262	2.625	88 @ .130	.181	4	.078	.188	N	2.481	.190
WSW-275	2.750	94 @ .170	.217	4	.093	.225	Y	2.602	.222
WSW-287	2.875	97 @ .170	.217	4	.093	.225	Y	2.721	.222
WSW-300	3.000	100 @ .170	.225	4	.093	.225	Y	2.838	.230
WSW-312	3.125	103 @ .170	.230	4	.093	.225	Y	2.957	.235
WSW-325	3.250	106 @ .170	.225	4	.093	.225	Y	3.076	.230
WSW-350	3.500	115 @ .185	.245	4	.111	.281	Y	3.316	.250
WSW-362	3.625	117 @ .185	.250	4	.111	.281	Y	3.435	.255
WSW-375	3.750	121 @ .185	.258	4	.111	.281	Y	3.552	.263
WSW-387	3.875	126 @ .185	.255	4	.111	.281	Y	3.673	.260
WSW-400	4.000	130 @ .185	.268	4	.111	.281	Y	3.792	.273
WSW-412	4.125	134 @ .185	.263	4	.111	.281	Y	3.919	.268
WSW-425	4.250	140 @ .185	.248	5	.111	.281	Y	4.065	.253
WSW-450	4.500	150 @ .185	.256	5	.111	.281	Y	4.310	.261
WSW-475	4.750	160 @ .185	.253	5	.111	.281	Y	4.550	.258
WSW-500	5.000	170 @ .185	.259	5	.111	.281	Y	4.790	.264

¹ Add suffix "-S17" for stainless steel.

² See pages 126-127 for How to Order.

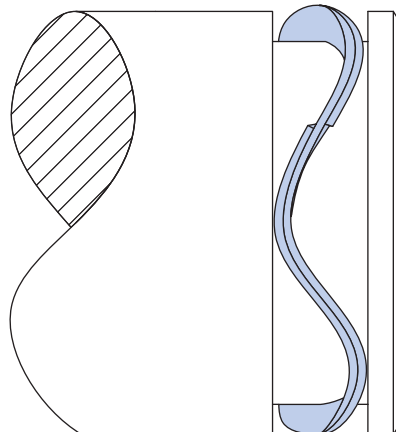

WST Series

Medium Heavy Duty Rings

Stock Items available in carbon steel and 302 and 316 stainless steel.

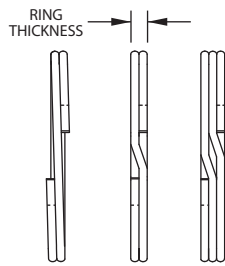
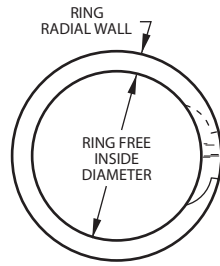
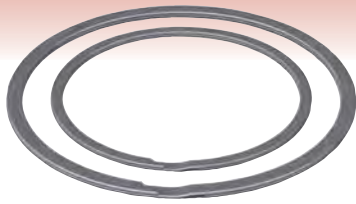

WST-46 / WS-150 WST-156 / WST-600 WST-625 & UP

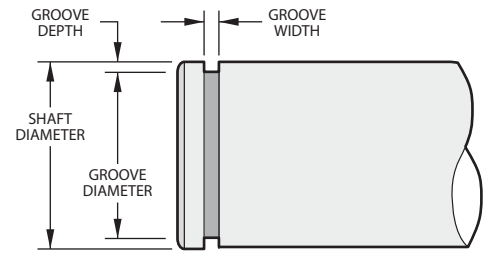

Product Dimensions All dimensions are in inches unless otherwise specified.

Smalley Part Number ^{1,4}	Shaft Diameter	Ring			Groove		Thrust Capacity	
		Inside Diameter	Radial Wall	Thickness	Diameter	Width	Groove Yield (lb) ²	Ring Shear (lb) ³
WST-46	.469	.436	.045	.025	.443	.029	430	1,800
WST-50	.500	.469	.045	.035	.474	.039	460	2,530
WST-55	.551	.518	.045	.035	.524	.039	550	2,790
WST-56	.562	.529	.045	.035	.535	.039	560	2,840
WST-59	.594	.559	.045	.035	.565	.039	630	3,000
WST-62	.625	.590	.055	.035	.596	.039	660	3,160
WST-66	.669	.630	.055	.035	.638	.039	760	3,380
WST-68	.688	.648	.065	.042	.655	.046	830	4,180
WST-75	.750	.708	.065	.042	.715	.046	950	4,550
WST-78	.781	.738	.065	.042	.745	.046	990	4,740
WST-81	.812	.768	.065	.042	.776	.046	1,030	4,930
WST-87	.875	.827	.075	.042	.835	.046	1,240	5,310
WST-93	.938	.886	.075	.042	.894	.046	1,460	5,690
WST-98	.984	.934	.075	.042	.940	.046	1,530	5,970
WST-100	1.000	.947	.075	.042	.955	.046	1,630	6,070
WST-102	1.023	.969	.075	.042	.977	.046	1,660	6,210
WST-106	1.062	1.005	.088	.050	1.015	.056	1,800	7,010
WST-112	1.125	1.064	.088	.050	1.075	.056	1,990	7,420
WST-118	1.188	1.126	.088	.050	1.135	.056	2,270	7,370
WST-125	1.250	1.184	.093	.050	1.195	.056	2,470	8,250
WST-131	1.312	1.240	.098	.050	1.250	.056	2,880	8,660
WST-137	1.375	1.298	.103	.050	1.310	.056	3,210	9,070
WST-143	1.438	1.359	.103	.050	1.370	.056	3,460	9,490
WST-150	1.500	1.419	.103	.050	1.430	.056	3,710	9,900
WST-156	1.562	1.476	.113	.062	1.490	.068	3,980	12,780
WST-162	1.625	1.537	.118	.062	1.550	.068	4,370	13,290
WST-168	1.687	1.598	.118	.062	1.610	.068	4,650	13,800
WST-175	1.750	1.657	.118	.062	1.670	.068	4,950	14,320
WST-177	1.771	1.676	.123	.062	1.689	.068	5,130	14,490
WST-181	1.812	1.714	.123	.062	1.730	.068	5,250	14,820
WST-187	1.875	1.774	.123	.062	1.790	.068	5,700	15,340
WST-196	1.969	1.864	.123	.062	1.879	.068	6,260	16,110
WST-200	2.000	1.894	.128	.062	1.910	.068	6,360	16,360
WST-206	2.062	1.955	.141	.078	1.970	.086	6,710	21,220
WST-212	2.125	2.012	.141	.078	2.027	.086	7,360	21,870
WST-215	2.156	2.041	.141	.078	2.057	.086	7,620	22,190
WST-225	2.250	2.129	.141	.078	2.145	.086	8,430	23,160
WST-231	2.312	2.188	.141	.078	2.205	.086	8,830	23,800
WST-237	2.375	2.248	.141	.078	2.265	.086	9,230	24,440
WST-243	2.437	2.307	.141	.078	2.325	.086	9,650	25,080
WST-250	2.500	2.366	.188	.078	2.385	.086	10,250	25,730
WST-255	2.559	2.424	.188	.078	2.443	.086	10,490	26,340
WST-262	2.625	2.485	.188	.078	2.505	.086	11,130	27,020
WST-268	2.687	2.545	.188	.078	2.565	.086	11,590	27,660

¹ Add suffix "-S02" for 302 stainless steel, "-S16" for 316 stainless steel.

² Based on a groove material strength of 45,000 psi and a safety factor of 2.

³ Based on a safety factor of 3.

⁴ See pages 126-127 for How to Order.

Smalley Part Number ^{1,4}	Shaft Diameter	Ring			Groove		Thrust Capacity	
		Inside Diameter	Radial Wall	Thickness	Diameter	Width	Groove Yield (lb) ²	Ring Shear (lb) ³
WST-275	2.750	2.604	.188	.093	2.625	.103	12,250	32,140
WST-287	2.875	2.722	.188	.093	2.742	.103	13,620	33,600
WST-293	2.937	2.780	.188	.093	2.801	.103	14,120	34,320
WST-300	3.000	2.838	.188	.093	2.860	.103	14,840	35,060
WST-306	3.062	2.897	.188	.093	2.920	.103	15,370	35,790
WST-312	3.125	2.957	.188	.093	2.980	.103	16,130	36,520
WST-315	3.156	2.986	.188	.093	3.010	.103	16,290	36,880
WST-325	3.250	3.075	.188	.093	3.100	.103	17,230	37,980
WST-334	3.344	3.164	.188	.093	3.190	.103	18,200	39,080
WST-343	3.437	3.254	.188	.093	3.280	.103	19,190	40,170
WST-350	3.500	3.315	.250	.111	3.340	.120	19,790	48,820
WST-354	3.543	3.356	.250	.111	3.381	.120	20,290	49,420
WST-362	3.625	3.433	.250	.111	3.458	.120	21,520	50,560
WST-368	3.687	3.490	.250	.111	3.517	.120	22,150	51,430
WST-375	3.750	3.550	.250	.111	3.577	.120	23,060	52,310
WST-387	3.875	3.670	.250	.111	3.696	.120	24,650	54,050
WST-393	3.938	3.730	.250	.111	3.756	.120	25,330	54,930
WST-400	4.000	3.787	.250	.111	3.815	.120	26,300	55,800
WST-425	4.250	4.032	.250	.111	4.065	.120	27,940	59,280
WST-437	4.375	4.162	.250	.111	4.190	.120	28,760	61,030
WST-450	4.500	4.280	.250	.111	4.310	.120	30,220	62,770
WST-475	4.750	4.515	.250	.111	4.550	.120	33,580	66,260
WST-500	5.000	4.755	.250	.111	4.790	.120	37,110	69,740
WST-525	5.250	4.995	.375	.127	5.030	.139	40,820	83,790
WST-550	5.500	5.229	.375	.127	5.265	.139	45,880	87,780
WST-575	5.750	5.466	.375	.127	5.505	.139	49,990	91,770
WST-600	6.000	5.705	.375	.127	5.745	.139	54,290	95,760

¹ Add suffix "-S02" for 302 stainless steel, "-S16" for 316 stainless steel.
² Based on a groove material yield strength of 45,000 psi and a safety factor of 2.
³ Based on a safety factor of 3.
⁴ See pages 126-127 for How to Order.

Rings listed below are three-turn construction.

Smalley Part Number ^{1,4}	Shaft Diameter	Ring			Groove		Thrust Capacity	
		Inside Diameter	Radial Wall	Thickness	Diameter	Width	Groove Yield (lb) ²	Ring Shear (lb) ³
WST-625	6.250	5.942	.312	.165	5.985	.174	58,760	129,590
WST-650	6.500	6.182	.312	.165	6.225	.174	63,410	134,780
WST-675	6.750	6.420	.312	.165	6.465	.174	68,230	139,960
WST-700	7.000	6.658	.312	.165	6.705	.174	73,230	145,140
WST-725	7.250	6.894	.312	.165	6.942	.174	78,290	172,190
WST-750	7.500	7.130	.375	.189	7.180	.209	84,820	178,130
WST-775	7.750	7.368	.375	.189	7.420	.209	90,390	184,070
WST-800	8.000	7.607	.375	.189	7.660	.209	96,130	190,000
WST-825	8.250	7.845	.375	.189	7.900	.209	102,050	195,940
WST-850	8.500	8.083	.375	.189	8.140	.209	108,150	201,880
WST-875	8.750	8.321	.375	.189	8.383	.209	113,800	207,820
WST-900	9.000	8.560	.375	.189	8.620	.209	120,870	213,750
WST-925	9.250	8.798	.375	.189	8.860	.209	127,500	219,690
WST-950	9.500	9.036	.375	.189	9.100	.209	134,300	225,630
WST-975	9.750	9.273	.375	.189	9.338	.209	141,970	231,570
WST-1000	10.000	9.508	.375	.189	9.575	.209	150,560	237,500

¹ Add suffix "-S02" for 302 stainless steel, "-S16" for 316 stainless steel.
² Based on a groove material yield strength of 45,000 psi and a safety factor of 2.
³ Based on a safety factor of 3.
⁴ See pages 126-127 for How to Order.

Stock Items available in carbon steel and 302 and 316 stainless steel.

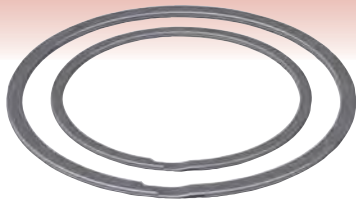

**AS3216, AS4299
MIL-DTL-27426/2**

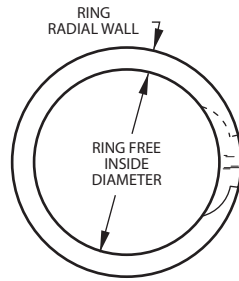

*No removal notch

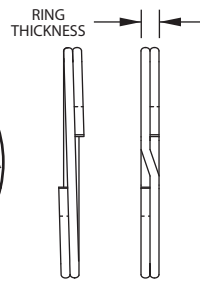

WSM-25 /
WSM-66

WSM-68
& UP

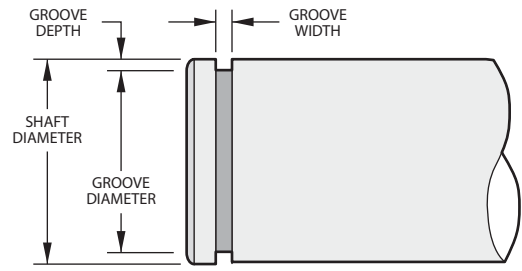

Product Dimensions All dimensions are in inches unless otherwise specified.

Smalley Part Number ^{1,4}	Shaft Diameter	Ring			Groove		Thrust Capacity	
		Inside Diameter	Radial Wall	Thickness	Diameter	Width	Groove Yield (lb) ²	Ring Shear (lb) ³
WSM-25*	.250	.228	.020	.025	.230	.029	177	961
WSM-31*	.312	.287	.025	.025	.290	.029	243	1,200
WSM-37*	.375	.349	.030	.025	.352	.029	305	1,442
WSM-43	.437	.409	.035	.025	.412	.029	386	1,680
WSM-46	.469	.439	.045	.025	.443	.029	430	1,880
WSM-50	.500	.464	.050	.035	.468	.039	570	2,530
WSM-55	.551	.514	.050	.035	.519	.039	620	2,790
WSM-56	.562	.525	.050	.035	.530	.039	640	2,840
WSM-59	.594	.554	.050	.035	.559	.039	760	3,000
WSM-62	.625	.583	.055	.035	.588	.039	840	3,160
WSM-66	.669	.623	.055	.035	.629	.039	950	3,380
WSM-68	.688	.641	.065	.042	.646	.046	1,020	4,180
WSM-75	.750	.698	.065	.042	.704	.046	1,220	4,550
WSM-78	.781	.727	.065	.042	.733	.046	1,330	4,740
WSM-81	.812	.756	.065	.042	.762	.046	1,440	4,930
WSM-87	.875	.814	.075	.042	.821	.046	1,670	5,310
WSM-93	.938	.875	.075	.042	.882	.046	1,860	5,690
WSM-98	.984	.919	.085	.042	.926	.046	2,020	5,970
WSM-100	1.000	.932	.085	.042	.940	.046	2,120	6,070
WSM-102	1.023	.953	.085	.042	.961	.046	2,240	6,210
WSM-106	1.062	.986	.103	.050	.998	.056	2,400	7,010
WSM-112	1.125	1.047	.103	.050	1.059	.056	2,620	7,420
WSM-118	1.188	1.105	.103	.050	1.118	.056	2,940	7,840
WSM-125	1.250	1.163	.103	.050	1.176	.056	3,270	8,250
WSM-131	1.312	1.218	.118	.050	1.232	.056	3,710	8,660
WSM-137	1.375	1.277	.118	.050	1.291	.056	4,080	9,070
WSM-143	1.438	1.336	.118	.050	1.350	.056	4,470	9,490
WSM-150	1.500	1.385	.118	.050	1.406	.056	4,980	9,900
WSM-156	1.562	1.453	.128	.062	1.468	.068	5,190	12,780
WSM-162	1.625	1.513	.128	.062	1.529	.068	5,510	13,290
WSM-168	1.687	1.573	.128	.062	1.589	.068	5,840	13,800
WSM-175	1.750	1.633	.128	.062	1.650	.068	6,190	14,320
WSM-177	1.771	1.651	.128	.062	1.669	.068	6,380	14,490
WSM-181	1.812	1.690	.128	.062	1.708	.068	6,660	14,820
WSM-187	1.875	1.751	.158	.062	1.769	.068	7,020	15,340
WSM-196	1.969	1.838	.158	.062	1.857	.068	7,790	16,110
WSM-200	2.000	1.867	.158	.062	1.886	.068	8,060	16,360
WSM-206	2.062	1.932	.168	.078	1.946	.086	8,450	21,220
WSM-212	2.125	1.989	.168	.078	2.003	.086	9,160	21,870
WSM-215	2.156	2.018	.168	.078	2.032	.086	9,450	22,190
WSM-225	2.250	2.105	.168	.078	2.120	.086	10,340	23,160
WSM-231	2.312	2.163	.168	.078	2.178	.086	10,950	23,800
WSM-237	2.375	2.223	.200	.078	2.239	.086	11,420	24,440
WSM-243	2.437	2.283	.200	.078	2.299	.086	11,890	25,080
WSM-250	2.500	2.343	.200	.078	2.360	.086	12,370	25,730
WSM-255	2.559	2.402	.200	.078	2.419	.086	12,660	26,340
WSM-262	2.625	2.464	.200	.078	2.481	.086	13,360	27,020
WSM-268	2.687	2.523	.200	.078	2.541	.086	13,870	27,660

¹ Add suffix "-S02" for 302 stainless steel, "-S16" for 316 stainless steel.

² Based on a groove material yield strength of 45,000 psi and a safety factor of 2.

³ Based on a safety factor of 3.

⁴ See pages 126-127 for How to Order.

Stock Items available in carbon steel and 302 and 316 stainless steel.

Product Dimensions All dimensions are in inches unless otherwise specified.

Smalley Part Number ^{1,4}	Shaft Diameter	Ring			Groove		Thrust Capacity	
		Inside Diameter	Radial Wall	Thickness	Diameter	Width	Groove Yield (lb) ²	Ring Shear (lb) ³
WSM-275	2.750	2.584	.225	.093	2.602	.103	14,390	32,140
WSM-287	2.875	2.702	.225	.093	2.721	.103	15,650	33,600
WSM-293	2.937	2.760	.225	.093	2.779	.103	16,400	34,320
WSM-300	3.000	2.818	.225	.093	2.838	.103	17,180	35,060
WSM-306	3.062	2.878	.225	.093	2.898	.103	17,750	35,790
WSM-312	3.125	2.936	.225	.093	2.957	.103	18,560	36,520
WSM-315	3.156	2.965	.225	.093	2.986	.103	18,960	36,880
WSM-325	3.250	3.054	.225	.093	3.076	.103	19,990	37,980
WSM-334	3.344	3.144	.225	.093	3.166	.103	21,040	39,080
WSM-343	3.437	3.234	.225	.093	3.257	.103	21,870	40,170
WSM-350	3.500	3.293	.270	.111	3.316	.120	22,760	48,820
WSM-354	3.543	3.333	.270	.111	3.357	.120	23,290	49,420
WSM-362	3.625	3.411	.270	.111	3.435	.120	24,340	50,560
WSM-368	3.687	3.469	.270	.111	3.493	.120	25,280	51,430
WSM-375	3.750	3.527	.270	.111	3.552	.120	26,240	52,310
WSM-387	3.875	3.647	.270	.111	3.673	.120	27,670	54,050
WSM-393	3.938	3.708	.270	.111	3.734	.120	28,390	54,930
WSM-400	4.000	3.765	.270	.111	3.792	.120	29,410	55,800
WSM-425	4.250	4.037	.270	.111	4.065	.120	27,940	59,280
WSM-437	4.375	4.161	.270	.111	4.190	.120	28,760	61,030
WSM-450	4.500	4.280	.270	.111	4.310	.120	30,220	62,770
WSM-475	4.750	4.518	.270	.111	4.550	.120	36,930	66,260
WSM-500	5.000	4.756	.270	.111	4.790	.120	37,110	69,740
WSM-525	5.250	4.995	.350	.127	5.030	.139	40,820	83,790
WSM-550	5.500	5.228	.350	.127	5.265	.139	45,880	87,780
WSM-575	5.750	5.466	.350	.127	5.505	.139	49,990	91,770
WSM-600	6.000	5.705	.350	.127	5.745	.139	54,290	95,760
WSM-625	6.250	5.938	.418	.156	5.985	.174	58,760	122,520
WSM-650	6.500	6.181	.418	.156	6.225	.174	63,410	127,420
WSM-675	6.750	6.410	.418	.156	6.465	.174	68,230	132,330
WSM-700	7.000	6.648	.418	.156	6.705	.174	73,230	137,230
WSM-725	7.250	6.891	.418	.156	6.942	.174	78,920	142,130
WSM-750	7.500	7.130	.437	.187	7.180	.209	84,820	176,240
WSM-775	7.750	7.368	.437	.187	7.420	.209	90,390	182,120
WSM-800	8.000	7.606	.437	.187	7.660	.209	96,130	187,990
WSM-825	8.250	7.845	.437	.187	7.900	.209	102,050	193,870
WSM-850	8.500	8.083	.437	.187	8.140	.209	108,150	199,740
WSM-875	8.750	8.324	.437	.187	8.383	.209	113,800	205,620
WSM-900	9.000	8.560	.500	.187	8.620	.209	120,870	211,490
WSM-925	9.250	8.798	.500	.187	8.860	.209	127,500	217,370
WSM-950	9.500	9.036	.500	.187	9.100	.209	134,300	223,240
WSM-975	9.750	9.275	.500	.187	9.338	.209	141,970	229,120
WSM-1000	10.000	9.508	.500	.187	9.575	.209	150,560	234,990
WSM-1025	10.250	9.745	.500	.187	9.814	.209	157,950	240,870
WSM-1050	10.500	9.984	.500	.187	10.054	.209	165,510	246,740
WSM-1075	10.750	10.221	.500	.187	10.293	.209	174,010	252,620
WSM-1100	11.000	10.459	.500	.187	10.533	.209	181,950	258,490
WSM-1125	11.250	10.692	.500	.187	10.772	.209	190,060	264,360
WSM-1150	11.500	10.934	.562	.187	11.011	.209	199,160	270,240
WSM-1175	11.750	11.171	.562	.187	11.250	.209	207,640	276,120
WSM-1200	12.000	11.410	.562	.187	11.490	.209	216,300	281,990
WSM-1225	12.250	11.647	.562	.187	11.729	.209	226,000	287,860
WSM-1250	12.500	11.885	.562	.187	11.969	.209	235,030	293,740
WSM-1275	12.750	12.124	.562	.187	12.208	.209	244,240	299,610
WSM-1300	13.000	12.361	.662	.187	12.448	.209	253,620	305,490
WSM-1325	13.250	12.598	.662	.187	12.687	.209	264,120	311,360
WSM-1350	13.500	12.837	.662	.187	12.927	.209	273,870	317,240
WSM-1375	13.750	13.074	.662	.187	13.166	.209	283,800	323,110
WSM-1400	14.000	13.311	.662	.187	13.405	.209	294,900	328,990
WSM-1425	14.250	13.548	.662	.187	13.644	.209	305,200	334,860
WSM-1450	14.500	13.787	.750	.187	13.884	.209	315,680	340,740
WSM-1475	14.750	14.024	.750	.187	14.123	.209	327,380	346,610
WSM-1500	15.000	14.262	.750	.187	14.363	.209	338,230	352,490

¹ Add suffix "-S02" for 302 stainless steel, "-S16" for 316 stainless steel.

² Based on a groove material yield strength of 45,000 psi and a safety factor of 2.

³ Based on a safety factor of 3.

⁴ See pages 126-127 for How to Order.

Stock Items available in carbon steel and 302 stainless steel.

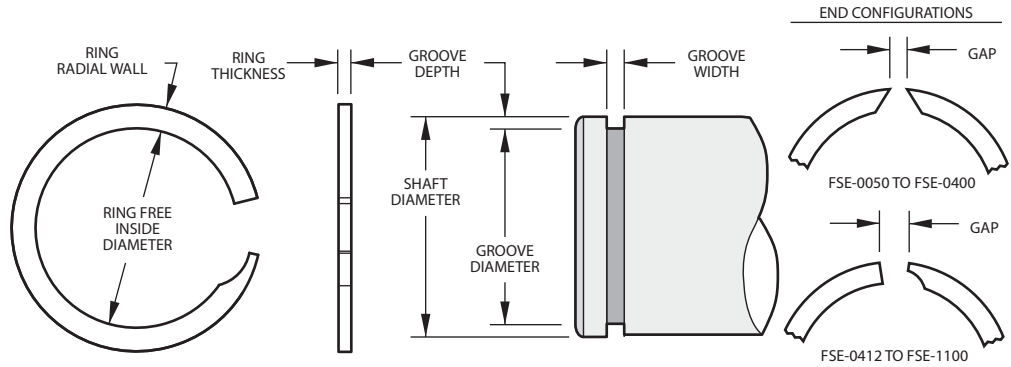
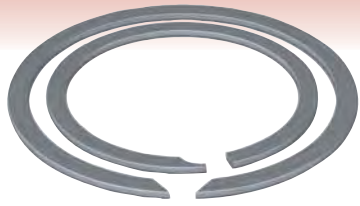

Product Dimensions All dimensions are in inches unless otherwise specified.

Smalley Part Number ^{1,4}	Shaft Diameter	Ring			Groove		Thrust Capacity	
		Inside Diameter	Radial Wall	Thickness	Diameter	Width	Groove Yield (lb) ²	Ring Shear (lb) ³
FSE-0050	.500	.471	.055	.037	.476	.043	424	2,325
FSE-0056	.562	.524	.055	.037	.532	.043	596	2,613
FSE-0062	.625	.590	.065	.037	.595	.043	663	2,906
FSE-0068	.687	.649	.065	.037	.655	.043	777	3,194
FSE-0075	.750	.701	.075	.045	.710	.051	1,060	4,241
FSE-0081	.812	.764	.075	.045	.772	.051	1,148	4,592
FSE-0087	.875	.820	.075	.045	.831	.051	1,361	4,948
FSE-0093	.937	.886	.085	.045	.893	.051	1,457	5,334
FSE-0100	1.000	.933	.085	.045	.952	.051	1,696	5,693
FSE-0106	1.062	1.004	.085	.045	1.014	.051	1,802	6,045
FSE-0112	1.125	1.069	.128	.057	1.077	.063	1,909	7,615
FSE-0118	1.187	1.116	.128	.057	1.131	.063	2,349	8,035
FSE-0125	1.250	1.176	.128	.057	1.188	.063	2,739	8,461
FSE-0131	1.312	1.223	.128	.057	1.242	.063	3,246	8,881
FSE-0137	1.375	1.282	.128	.057	1.297	.063	3,791	9,307
FSE-0143	1.437	1.344	.158	.067	1.359	.073	3,961	11,408
FSE-0150	1.500	1.402	.158	.067	1.422	.073	4,135	11,908
FSE-0156	1.562	1.457	.158	.067	1.470	.073	5,079	12,400
FSE-0162	1.625	1.517	.158	.067	1.533	.073	5,284	12,901
FSE-0168	1.687	1.578	.158	.067	1.595	.073	5,485	13,393
FSE-0175	1.750	1.640	.158	.067	1.658	.073	5,690	13,893
FSE-0181	1.812	1.697	.158	.067	1.720	.073	5,892	14,385
FSE-0187	1.875	1.767	.158	.067	1.783	.073	6,097	14,885
FSE-0193	1.937	1.800	.200	.076	1.819	.085	8,078	16,649
FSE-0200	2.000	1.862	.200	.076	1.882	.085	8,341	17,191
FSE-0206	2.062	1.924	.200	.076	1.944	.085	8,599	17,724
FSE-0212	2.125	1.987	.200	.076	2.007	.085	8,862	18,265
FSE-0218	2.187	2.048	.200	.076	2.069	.085	9,121	18,798
FSE-0225	2.250	2.110	.200	.076	2.132	.085	9,384	19,340
FSE-0231	2.312	2.171	.200	.076	2.194	.085	9,642	19,873
FSE-0237	2.375	2.226	.200	.076	2.257	.085	9,905	20,414
FSE-0243	2.437	2.296	.200	.076	2.319	.085	10,163	20,947
FSE-0250	2.500	2.357	.200	.076	2.382	.085	10,426	21,488
FSE-0256	2.562	2.415	.200	.095	2.444	.104	10,685	26,252
FSE-0262	2.625	2.486	.200	.095	2.507	.104	10,947	26,898
FSE-0268	2.687	2.537	.200	.095	2.569	.104	11,206	27,533
FSE-0275	2.750	2.607	.200	.095	2.632	.104	11,469	28,179
FSE-0281	2.812	2.665	.200	.095	2.694	.104	11,727	28,814
FSE-0287	2.875	2.727	.200	.095	2.757	.104	11,990	29,460
FSE-0293	2.937	2.789	.200	.095	2.819	.104	12,249	30,095

¹ Add suffix "-S02" for 302 stainless steel.

² Based on a groove material yield strength of 45,000 psi and a safety factor of 2.

³ Based on a safety factor of 3.

⁴ See pages 126-127 for How to Order.

Stock Items available in carbon steel and 302 stainless steel.

Product Dimensions All dimensions are in inches unless otherwise specified.

Smalley Part Number ^{1,4}	Shaft Diameter	Ring			Groove		Thrust Capacity	
		Inside Diameter	Radial Wall	Thickness	Diameter	Width	Groove Yield (lb) ²	Ring Shear (lb) ³
FSE-0300	3.000	2.852	.200	.095	2.882	.104	12,511	30,740
FSE-0306	3.062	2.916	.200	.095	2.944	.104	12,770	31,376
FSE-0312	3.125	2.955	.237	.095	2.987	.104	15,242	32,021
FSE-0318	3.187	3.016	.237	.095	3.049	.104	15,544	32,657
FSE-0325	3.250	3.079	.237	.095	3.112	.104	15,851	33,302
FSE-0331	3.312	3.140	.248	.115	3.174	.124	16,154	39,088
FSE-0337	3.375	3.203	.248	.115	3.237	.124	16,461	39,831
FSE-0343	3.437	3.264	.248	.115	3.299	.124	16,763	40,563
FSE-0350	3.500	3.326	.248	.115	3.362	.124	17,071	41,307
FSE-0356	3.562	3.378	.248	.115	3.424	.124	17,373	42,038
FSE-0362	3.625	3.451	.248	.115	3.487	.124	17,680	42,782
FSE-0368	3.687	3.512	.248	.115	3.549	.124	17,983	43,514
FSE-0375	3.750	3.570	.248	.115	3.612	.124	18,290	44,257
FSE-0381	3.812	3.636	.248	.115	3.674	.124	18,592	44,989
FSE-0387	3.875	3.689	.248	.115	3.737	.124	18,900	45,732
FSE-0393	3.937	3.760	.248	.115	3.799	.124	19,202	46,464
FSE-0400	4.000	3.828	.248	.115	3.862	.124	19,509	47,208
FSE-0412	4.125	3.930	.265	.153	3.967	.163	23,035	62,126
FSE-0425	4.250	4.050	.265	.153	4.092	.163	23,733	64,008
FSE-0437	4.375	4.174	.265	.153	4.217	.163	24,431	65,891
FSE-0450	4.500	4.297	.265	.153	4.342	.163	25,129	67,774
FSE-0462	4.625	4.421	.265	.153	4.467	.163	25,827	69,656
FSE-0475	4.750	4.530	.265	.153	4.592	.163	26,525	71,539
FSE-0487	4.875	4.668	.265	.153	4.717	.163	27,223	73,421
FSE-0500	5.000	4.792	.265	.153	4.842	.163	27,921	75,304
FSE-0525	5.250	5.039	.265	.153	5.092	.163	29,317	79,069
FSE-0550	5.500	5.292	.265	.153	5.342	.163	30,713	82,834
FSE-0575	5.750	5.535	.265	.153	5.592	.163	32,109	86,599
FSE-0600	6.000	5.744	.316	.153	5.804	.163	41,563	90,365
FSE-0625	6.250	5.992	.316	.153	6.054	.163	43,295	94,130
FSE-0650	6.500	6.236	.316	.153	6.304	.163	45,027	97,895
FSE-0675	6.750	6.486	.316	.153	6.554	.163	46,759	101,727
FSE-0700	7.000	6.734	.316	.153	6.804	.163	48,490	105,494
FSE-0725	7.250	6.993	.316	.153	7.054	.163	50,222	109,262
FSE-0750	7.500	7.219	.316	.153	7.304	.163	51,954	113,030
FSE-0775	7.750	7.477	.316	.153	7.554	.163	53,686	116,797
FSE-0800	8.000	7.683	.435	.192	7.764	.203	66,727	142,932
FSE-0825	8.250	7.940	.435	.192	8.014	.203	68,813	147,399
FSE-0850	8.500	8.179	.435	.192	8.264	.203	70,898	151,866
FSE-0875	8.750	8.427	.435	.192	8.514	.203	72,983	156,332
FSE-0900	9.000	8.673	.435	.192	8.764	.203	75,068	160,799
FSE-0925	9.250	8.922	.435	.192	9.014	.203	77,154	165,265
FSE-0950	9.500	9.130	.435	.192	9.240	.203	87,297	169,732
FSE-0975	9.750	9.393	.435	.192	9.490	.203	89,594	174,199
FSE-1000	10.000	9.586	.500	.192	9.686	.203	110,977	178,665
FSE-1025	10.250	9.826	.500	.192	9.936	.203	113,751	183,132
FSE-1050	10.500	10.081	.500	.192	10.186	.203	116,526	187,599
FSE-1075	10.750	10.329	.500	.192	10.436	.203	119,300	192,065
FSE-1100	11.000	10.584	.500	.192	10.686	.203	122,074	196,532

¹ Add suffix "-S02" for 302 stainless steel.

² Based on a groove material yield strength of 45,000 psi and a safety factor of 2.

³ Based on a safety factor of 3.

⁴ See pages 126-127 for How to Order.

Stock Items available in carbon steel and 302 and 316 stainless steel.

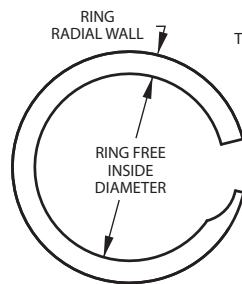
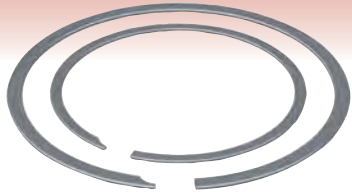

*No removal notch

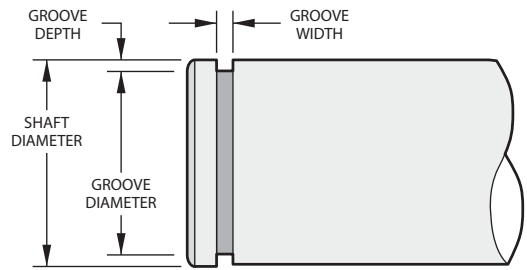
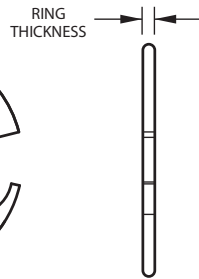

Product Dimensions All dimensions are in millimeters unless otherwise specified.

Smalley Part Number ^{1,4}	Shaft Diameter	Ring			Groove		Thrust Capacity	
		Inside Diameter	Radial Wall	Thickness	Diameter	Width	Groove Yield (kN) ²	Ring Shear (kN) ³
VSM-6*	6.00	5.65	.51	.30	5.70	.38	.44	1.99
VSM-7*	7.00	6.58	.51	.30	6.64	.38	.61	2.23
VSM-8*	8.00	7.52	.64	.38	7.60	.46	.78	3.18
VSM-9*	9.00	8.42	.76	.38	8.50	.46	1.11	3.58
VSM-10*	10.00	9.32	.89	.38	9.40	.46	1.46	3.98
VSM-11	11.00	10.32	.89	.38	10.40	.46	1.61	4.38
VSM-12	12.00	11.22	1.14	.46	11.34	.56	1.93	5.78
VSM-13	13.00	12.15	1.14	.46	12.28	.56	2.28	6.26
VSM-14	14.00	13.15	1.14	.46	13.28	.56	2.46	6.74
VSM-15	15.00	14.14	1.14	.46	14.28	.56	2.63	7.22
VSM-16	16.00	15.13	1.14	.46	15.28	.56	2.81	7.71
VSM-17	17.00	16.13	1.14	.46	16.28	.56	2.98	8.19
VSM-18	18.00	17.12	1.14	.46	17.28	.56	3.16	8.67
VSM-19	19.00	18.11	1.14	.46	18.28	.56	3.33	9.15
VSM-20	20.00	19.10	1.14	.46	19.28	.56	3.51	9.63
VSM-21	21.00	19.74	1.65	.53	19.94	.66	5.42	11.65
VSM-22	22.00	20.73	1.65	.53	20.94	.66	5.68	12.21
VSM-24	24.00	22.72	1.65	.53	22.94	.66	6.20	13.32
VSM-25	25.00	23.71	1.65	.53	23.94	.66	6.46	13.87
VSM-26	26.00	24.63	2.24	.64	24.88	.79	7.10	15.14
VSM-28	28.00	26.62	2.24	.64	26.88	.79	7.64	16.30
VSM-29	29.00	27.61	2.24	.64	27.88	.79	7.91	16.88
VSM-30	30.00	28.59	2.24	.64	28.88	.79	8.19	17.47
VSM-32	32.00	30.57	2.24	.64	30.88	.79	8.73	18.63
VSM-34	34.00	32.56	2.24	.64	32.88	.79	9.28	19.80
VSM-35	35.00	33.55	2.24	.64	33.88	.79	9.55	20.38
VSM-36	36.00	34.54	2.24	.64	34.88	.79	9.83	20.96
VSM-38	38.00	36.52	2.24	.64	36.88	.79	10.37	22.12
VSM-40	40.00	38.09	3.00	.79	38.52	.99	14.43	28.75
VSM-42	42.00	40.07	3.00	.79	40.52	.99	15.15	30.19
VSM-45	45.00	43.04	3.00	.79	43.52	.99	16.23	32.34
VSM-48	48.00	46.01	3.00	.79	46.52	.99	17.31	34.50
VSM-50	50.00	47.99	3.00	.79	48.52	.99	18.03	35.93
VSM-52	52.00	49.48	4.01	.79	50.06	.99	24.58	37.37
VSM-55	55.00	52.46	4.01	.79	53.06	.99	26.00	39.53
VSM-56	56.00	53.44	4.01	.79	54.06	.99	26.47	40.25
VSM-58	58.00	55.42	4.01	.79	56.06	.99	27.42	41.68
VSM-60	60.00	57.40	4.01	.79	58.06	.99	28.36	43.12
VSM-62	62.00	59.37	4.01	.79	60.06	.99	29.31	44.56
VSM-63	63.00	60.35	4.01	.79	61.06	.99	29.78	45.28
VSM-65	65.00	62.33	4.01	.79	63.06	.99	30.73	46.72
VSM-68	68.00	65.31	4.01	.79	66.06	.99	32.15	48.87
VSM-70	70.00	67.29	4.01	.79	68.06	.99	33.09	50.31
VSM-72	72.00	69.27	4.01	.79	70.06	.99	34.04	51.75
VSM-75	75.00	72.25	4.01	.79	73.06	.99	35.45	53.90

¹ Add suffix "-S02" for 302 stainless steel. Add suffix "-S16" for 316 stainless steel.

² Based on a groove material yield strength of 310 N/mm² and a safety factor of 2.

³ Based on a safety factor of 3.

⁴ See pages 126-127 for How to Order.

Stock Items available in carbon steel and 302 and 316 stainless steel.

Product Dimensions All dimensions are in millimeters unless otherwise specified.

Smalley Part Number ^{1,4}	Shaft Diameter	Ring			Groove		Thrust Capacity	
		Inside Diameter	Radial Wall	Thickness	Diameter	Width	Groove Yield (kN) ²	Ring Shear (kN) ³
VSM-78	78.00	74.85	4.78	.99	75.66	1.12	44.48	70.25
VSM-80	80.00	76.82	4.78	.99	77.66	1.12	45.62	72.05
VSM-82	82.00	78.79	4.78	.99	79.66	1.12	46.76	73.85
VSM-85	85.00	81.76	4.78	.99	82.66	1.12	48.47	76.55
VSM-88	88.00	84.73	4.78	.99	85.66	1.12	50.18	79.26
VSM-90	90.00	86.69	4.78	.99	87.66	1.12	51.32	81.06
VSM-95	95.00	91.66	4.78	.99	92.66	1.12	54.17	85.56
VSM-100	100.00	96.62	4.78	.99	97.66	1.12	57.02	90.06
VSM-105	105.00	101.13	5.72	1.17	102.20	1.32	71.64	106.44
VSM-110	110.00	106.08	5.72	1.17	107.20	1.32	75.05	111.51
VSM-115	115.00	111.03	5.72	1.17	112.20	1.32	78.47	116.58
VSM-120	120.00	115.98	5.72	1.17	117.20	1.32	81.88	121.65
VSM-125	125.00	120.93	5.72	1.17	122.20	1.32	85.29	126.71
VSM-130	130.00	125.88	5.72	1.17	127.20	1.32	88.70	131.78
VSM-135	135.00	130.31	5.72	1.55	131.63	1.70	111.03	181.30
VSM-140	140.00	135.13	5.72	1.55	136.50	1.70	119.40	188.01
VSM-150	150.00	144.83	5.72	1.55	146.25	1.70	137.07	201.44
VSM-155	155.00	149.66	5.72	1.55	151.13	1.70	146.36	208.16
VSM-160	160.00	154.44	6.73	1.55	156.00	1.70	155.96	214.87
VSM-165	165.00	159.27	6.73	1.55	160.88	1.70	165.86	221.59
VSM-170	170.00	164.09	6.73	1.55	165.75	1.70	176.06	228.30
VSM-175	175.00	168.92	6.73	1.55	170.63	1.70	186.57	235.02
VSM-180	180.00	173.75	6.73	1.55	175.50	1.70	197.38	241.73
VSM-185	185.00	178.57	7.62	1.55	180.38	1.70	208.50	248.45
VSM-190	190.00	183.40	7.62	1.55	185.25	1.70	219.92	255.16
VSM-195	195.00	188.22	7.62	1.55	190.13	1.70	231.65	261.88
VSM-200	200.00	193.05	7.62	1.55	195.00	1.70	243.68	268.59
VSM-210	210.00	202.70	8.76	1.93	204.75	2.08	268.66	351.16
VSM-220	220.00	212.36	8.76	1.93	214.50	2.08	294.85	367.88
VSM-230	230.00	222.01	8.76	1.93	224.25	2.08	322.27	384.60
VSM-240	240.00	231.66	8.76	1.93	234.00	2.08	350.90	401.33
VSM-250	250.00	241.31	8.76	1.93	243.75	2.08	380.75	418.05
VSM-260	260.00	250.97	9.65	1.93	253.50	2.08	411.82	434.77
VSM-270	270.00	260.62	9.65	1.93	263.25	2.08	444.11	451.49
VSM-280	280.00	270.27	9.65	1.93	273.00	2.08	477.61	468.21
VSM-290	290.00	279.92	9.65	1.93	282.75	2.08	512.34	484.94
VSM-300	300.00	289.58	9.65	1.93	292.50	2.08	548.28	501.66

¹ Add suffix "-S02" for 302 stainless steel. Add suffix "-S16" for 316 stainless steel.
² Based on a groove material yield strength of 310 N/mm² and a safety factor of 2.
³ Based on a safety factor of 3.
⁴ See pages 126-127 for How to Order.

Stock Items available in carbon steel and 302 and 316 stainless steel.

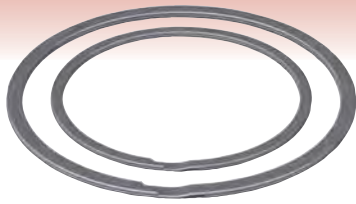

MA 4016⁵

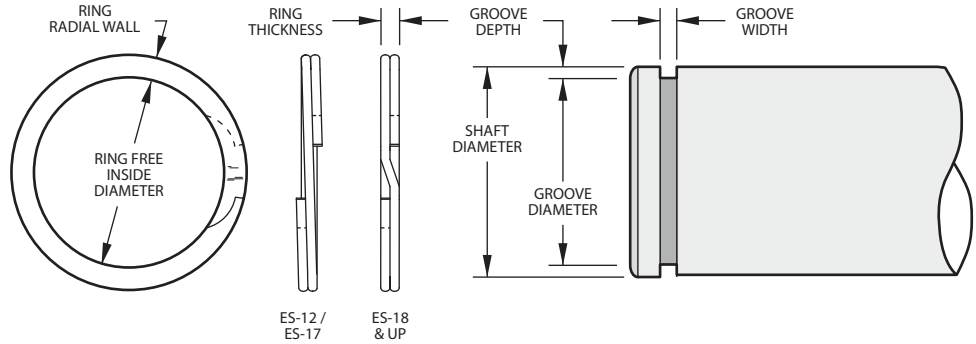

Product Dimensions All dimensions are in millimeters unless otherwise specified.

Smalley Part Number ^{1,4}	Shaft Diameter	Ring			Groove		Thrust Capacity	
		Inside Diameter	Radial Wall	Thickness	Diameter	Width	Groove Yield (N) ²	Ring Shear (N) ³
ES-12	12.00	11.18	1.02 - 1.22	.60	11.29	.70	2,100	7,950
ES-13	13.00	12.13	1.14 - 1.35	.89	12.24	1.00	2,410	12,100
ES-14	14.00	13.06	1.14 - 1.35	.89	13.19	1.00	2,800	13,040
ES-15	15.00	13.98	1.14 - 1.35	.89	14.09	1.00	3,360	13,970
ES-16	16.00	14.90	1.27 - 1.48	.89	15.02	1.00	3,820	14,900
ES-17	17.00	15.82	1.27 - 1.48	.89	16.02	1.00	4,060	15,830
ES-18	18.00	16.80	1.52 - 1.73	1.07	16.92	1.20	4,730	20,150
ES-19	19.00	17.73	1.52 - 1.73	1.07	17.87	1.20	5,270	21,270
ES-20	20.00	18.62	1.52 - 1.73	1.07	18.77	1.20	6,040	22,390
ES-21	21.00	19.57	1.52 - 1.73	1.07	19.72	1.20	6,550	23,510
ES-22	22.00	20.45	1.78 - 1.98	1.07	20.62	1.20	7,390	24,630
ES-23	23.00	21.39	1.78 - 1.98	1.07	21.57	1.20	8,070	25,750
ES-24	24.00	22.35	1.78 - 1.98	1.07	22.52	1.20	8,650	26,870
ES-25	25.00	23.25	2.03 - 2.24	1.07	23.42	1.20	9,620	27,990
ES-26	26.00	24.21	2.03 - 2.24	1.07	24.42	1.20	10,000	29,110
ES-27	27.00	25.04	2.49 - 2.69	1.27	25.35	1.40	10,910	31,170
ES-28	28.00	26.00	2.49 - 2.69	1.27	26.30	1.40	11,590	32,330
ES-29	29.00	26.95	2.49 - 2.69	1.27	27.27	1.40	12,290	33,480
ES-30	30.00	27.92	2.49 - 2.69	1.27	28.25	1.40	12,860	34,640
ES-31	31.00	28.84	2.49 - 2.69	1.27	29.17	1.40	13,890	35,790
ES-32	32.00	29.77	2.49 - 2.69	1.27	30.09	1.40	14,960	36,950
ES-34	34.00	31.54	2.87 - 3.07	1.27	31.90	1.40	17,390	39,260
ES-35	35.00	32.44	2.87 - 3.07	1.27	32.80	1.40	18,750	40,410
ES-36	36.00	33.40	2.87 - 3.07	1.27	33.75	1.40	19,810	41,560
ES-37	37.00	34.24	2.87 - 3.07	1.27	34.67	1.40	21,080	42,720
ES-38	38.00	35.18	2.87 - 3.07	1.27	35.66	1.40	21,650	43,870
ES-40	40.00	37.15	3.12 - 3.33	1.57	37.55	1.75	23,960	57,090
ES-42	42.00	39.02	3.12 - 3.33	1.57	39.45	1.75	26,180	59,990
ES-45	45.00	41.77	3.12 - 3.33	1.57	42.25	1.75	30,240	64,230
ES-46	46.00	42.67	3.12 - 3.33	1.57	43.15	1.75	32,040	65,660
ES-47	47.00	43.81	3.89 - 4.09	1.57	44.31	1.75	30,900	67,080
ES-48	48.00	44.48	3.89 - 4.09	1.57	45.05	1.75	34,600	68,510
ES-50	50.00	46.69	3.89 - 4.09	1.57	47.05	1.75	36,040	71,370
ES-52	52.00	49.62	3.12 - 3.33	1.25	50.15	1.42	23,550	59,090
ES-53	53.00	50.62	3.12 - 3.33	1.25	51.15	1.42	24,000	60,230
ES-54	54.00	51.62	3.12 - 3.33	1.25	52.15	1.42	24,460	61,370
ES-55	55.00	52.62	3.38 - 3.58	1.25	53.15	1.42	24,910	62,500
ES-56	56.00	53.62	3.38 - 3.58	1.25	54.15	1.42	25,370	63,640
ES-58	58.00	55.43	3.38 - 3.58	1.25	56.01	1.42	28,250	65,910
ES-59	59.00	56.43	3.38 - 3.58	1.25	57.01	1.42	28,730	67,050
ES-60	60.00	57.43	3.38 - 3.58	1.25	58.01	1.42	29,220	68,180
ES-61	61.00	58.36	3.38 - 3.58	1.25	58.91	1.42	31,190	69,320
ES-62	62.00	59.30	3.63 - 3.84	1.25	59.91	1.42	31,710	70,460
ES-63	63.00	60.30	3.63 - 3.84	1.25	60.91	1.42	32,220	71,590
ES-64	64.00	61.25	3.63 - 3.84	1.25	61.91	1.42	32,730	72,730

¹ Add suffix "-S02" for 302 stainless steel, "-S16" for 316 stainless steel.

² Based on a groove material yield strength of 310 N/mm² and a safety factor of 2.

³ Based on a safety factor of 3.

⁴ See pages 126-127 for How to Order.

⁵ Contact Smalley for details/information on how to order parts to be in compliance with this specification.

Stock Items available in carbon steel and 302 and 316 stainless steel.

Product Dimensions All dimensions are in millimeters unless otherwise specified.

Smalley Part Number ^{1,4}	Shaft Diameter	Ring			Groove		Thrust Capacity	
		Inside Diameter	Radial Wall	Thickness	Diameter	Width	Groove Yield (N) ²	Ring Shear (N) ³
ES-65	65.00	62.20	3.63 - 3.84	1.25	62.81	1.42	34,820	73,870
ES-66	66.00	63.16	3.63 - 3.84	1.25	63.79	1.42	35,680	75,000
ES-67	67.00	64.16	3.63 - 3.84	1.25	64.71	1.42	37,530	76,140
ES-68	68.00	65.08	3.89 - 4.09	1.25	65.71	1.42	38,090	77,270
ES-69	69.00	66.06	3.89 - 4.09	1.25	66.71	1.42	38,650	78,410
ES-70	70.00	67.08	3.89 - 4.09	1.25	67.71	1.42	39,210	79,550
ES-71	71.00	68.04	3.89 - 4.09	1.25	68.71	1.42	39,770	80,680
ES-72	72.00	69.00	4.11 - 4.37	1.25	69.65	1.42	41,380	81,820
ES-75	75.00	71.93	4.11 - 4.37	1.25	72.61	1.42	43,830	85,230
ES-78	78.00	74.84	4.11 - 4.37	1.55	75.55	1.73	46,730	109,910
ES-80	80.00	76.80	4.37 - 4.62	1.55	77.51	1.73	48,700	112,730
ES-82	82.00	78.72	4.37 - 4.62	1.55	79.45	1.73	51,120	115,550
ES-85	85.00	81.62	4.62 - 4.88	1.55	82.35	1.73	55,060	119,780
ES-88	88.00	84.53	4.62 - 4.88	1.55	85.31	1.73	57,860	124,000
ES-90	90.00	86.43	4.88 - 5.13	1.55	87.21	1.73	61,370	126,820
ES-95	95.00	91.37	4.88 - 5.13	1.55	92.15	1.73	66,160	133,870
ES-100	100.00	96.10	5.13 - 5.38	1.55	97.01	1.73	73,050	140,910
ES-105	105.00	100.94	5.38 - 5.64	1.55	101.85	1.73	80,780	147,960
ES-110	110.00	105.75	5.64 - 5.89	1.55	106.69	1.73	88,930	155,000
ES-115	115.00	110.59	5.89 - 6.15	1.55	111.55	1.73	96,890	162,050
ES-120	120.00	115.49	6.20 - 6.45	1.83	116.45	2.00	104,030	199,640
ES-125	125.00	120.44	6.20 - 6.45	1.83	121.45	2.00	108,360	207,960
ES-130	130.00	125.34	6.20 - 6.45	1.83	126.35	2.00	115,860	216,280
ES-135	135.00	130.20	6.20 - 6.45	1.83	131.27	2.00	122,950	224,600
ES-140	140.00	135.14	6.20 - 6.45	1.83	136.25	2.00	128,190	232,920
ES-145	145.00	140.00	6.20 - 6.45	1.83	141.17	2.00	135,590	241,230
ES-150	150.00	145.00	6.20 - 6.45	1.83	146.17	2.00	140,260	249,550
ES-155	155.00	149.33	7.72 - 8.03	2.18	150.60	2.40	166,080	307,190
ES-160	160.00	154.31	7.72 - 8.03	2.18	155.60	2.40	171,430	317,100
ES-165	165.00	159.23	7.72 - 8.03	2.18	160.60	2.40	176,790	327,010
ES-170	170.00	164.00	7.72 - 8.03	2.18	165.40	2.40	190,430	336,920
ES-175	175.00	169.00	7.72 - 8.03	2.18	170.40	2.40	196,030	346,830
ES-180	180.00	173.78	7.72 - 8.03	2.18	175.20	2.40	210,400	356,740
ES-185	185.00	178.70	7.72 - 8.03	2.18	180.20	2.40	216,240	366,650
ES-190	190.00	183.70	7.72 - 8.03	2.18	185.20	2.40	220,080	376,560
ES-195	195.00	188.43	7.72 - 8.03	2.18	190.00	2.40	237,420	386,460
ES-200	200.00	193.43	7.72 - 8.03	2.18	195.00	2.40	243,510	396,370
ES-210	210.00	202.93	9.32 - 9.63	2.18	204.60	2.40	276,140	416,190
ES-220	220.00	212.65	9.32 - 9.63	2.18	214.40	2.40	300,010	436,010
ES-230	230.00	222.60	9.32 - 9.63	2.18	224.40	2.40	313,640	455,830
ES-240	240.00	232.32	9.32 - 9.63	2.18	234.20	2.40	328,970	475,650
ES-250	250.00	241.83	9.32 - 9.63	2.18	243.80	2.40	377,440	495,470
ES-260	260.00	251.57	9.32 - 9.63	2.18	253.60	2.40	405,210	515,290
ES-270	270.00	261.30	9.32 - 9.63	2.18	263.40	2.40	433,940	535,100
ES-280	280.00	271.04	9.32 - 9.63	2.18	273.20	2.40	463,650	554,920

¹ Add suffix "-S02" for 302 stainless steel, "-S16" for 316 stainless steel.

² Based on a groove material yield strength of 310 N/mm² and a safety factor of 2.

³ Based on a safety factor of 3.

⁴ See pages 126-127 for How to Order.

⁵ Contact Smalley for details/information on how to order parts to be in compliance with this specification.

DNS Series

DIN Metric Rings

Stock Items available in carbon steel and 302 and 316 stainless steel.

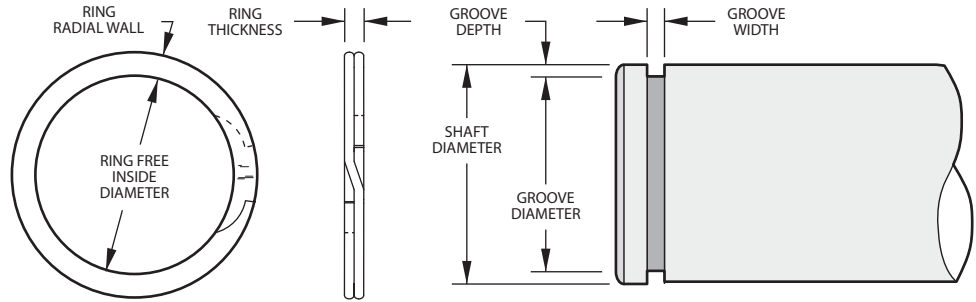
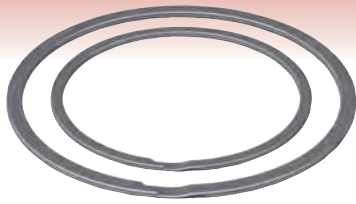

European Specification
Incorporating DIN 471

Product Dimensions All dimensions are in millimeters unless otherwise specified.

Smalley Part Number ^{1,4}	Shaft Diameter	Ring			Groove		Thrust Capacity	
		Inside Diameter	Radial Wall	Thickness	Diameter	Width	Groove Yield (N) ²	Ring Shear (N) ³
DNS-13	13.00	12.27	1.40	.99	12.40	1.10	1,901	13,474
DNS-14	14.00	13.26	1.40	.99	13.40	1.10	2,047	14,510
DNS-15	15.00	14.15	1.40	.99	14.30	1.10	2,559	15,547
DNS-16	16.00	15.04	1.65	.99	15.20	1.10	3,119	16,583
DNS-17	17.00	16.04	1.65	.99	16.20	1.10	3,314	17,620
DNS-18	18.00	16.83	1.91	1.14	17.00	1.30	4,386	18,668
DNS-19	19.00	17.83	1.91	1.14	18.00	1.30	4,630	19,705
DNS-20	20.00	18.82	1.91	1.14	19.00	1.30	4,874	20,742
DNS-21	21.00	19.79	1.91	1.14	20.00	1.30	5,117	21,779
DNS-22	22.00	20.78	1.91	1.14	21.00	1.30	5,361	22,816
DNS-23	23.00	21.77	1.91	1.14	22.00	1.30	5,605	23,853
DNS-24	24.00	22.66	2.18	1.14	22.90	1.30	6,433	24,891
DNS-25	25.00	23.65	2.18	1.14	23.90	1.30	6,701	25,928
DNS-26	26.00	24.64	2.18	1.14	24.90	1.30	6,969	26,965
DNS-27	27.00	25.34	2.18	1.14	25.60	1.30	9,211	28,002
DNS-28	28.00	26.34	2.39	1.44	26.60	1.60	9,552	36,681
DNS-29	29.00	27.33	2.39	1.44	27.60	1.60	9,893	37,991
DNS-30	30.00	28.32	2.39	1.44	28.60	1.60	10,235	39,301
DNS-32	32.00	30.00	3.25	1.44	30.30	1.60	13,256	41,921
DNS-33	33.00	30.99	3.25	1.44	31.30	1.60	13,670	43,231
DNS-34	34.00	31.98	3.25	1.44	32.30	1.60	14,085	44,541
DNS-35	35.00	32.66	3.25	1.44	33.00	1.60	17,058	45,851
DNS-36	36.00	33.65	4.01	1.69	34.00	1.85	17,545	55,349
DNS-38	38.00	35.64	4.01	1.69	36.00	1.85	18,520	58,424
DNS-40	40.00	37.11	4.01	1.69	37.50	1.85	24,368	61,498
DNS-42	42.00	39.09	4.01	1.69	39.50	1.85	25,586	64,573
DNS-45	45.00	42.06	4.01	1.69	42.50	1.85	27,414	69,186
DNS-46	46.00	43.05	4.01	1.69	43.50	1.85	28,023	70,723
DNS-47	47.00	44.04	4.01	1.69	44.50	1.85	28,633	72,261
DNS-48	48.00	45.03	4.01	1.69	45.50	1.85	29,242	73,798
DNS-50	50.00	46.53	5.08	1.93	47.00	2.15	36,552	87,790
DNS-52	52.00	48.51	5.08	1.93	49.00	2.15	38,014	91,302
DNS-54	54.00	50.50	5.08	1.93	51.00	2.15	39,476	94,813
DNS-55	55.00	51.49	5.08	1.93	52.00	2.15	40,207	96,569
DNS-56	56.00	52.48	5.08	1.93	53.00	2.15	40,938	98,325
DNS-58	58.00	54.43	5.08	1.93	55.00	2.15	42,400	101,836
DNS-60	60.00	56.42	5.08	1.93	57.00	2.15	43,863	105,348
DNS-62	62.00	58.42	5.08	1.93	59.00	2.15	45,325	108,860
DNS-63	63.00	59.39	5.08	1.93	60.00	2.15	46,056	110,615
DNS-65	65.00	61.39	5.08	2.41	62.00	2.65	47,518	135,725
DNS-67	67.00	63.37	5.08	2.41	64.00	2.65	48,980	139,901
DNS-68	68.00	64.34	5.08	2.41	65.00	2.65	49,711	141,989
DNS-70	70.00	66.34	5.08	2.41	67.00	2.65	51,173	146,165
DNS-72	72.00	68.33	5.08	2.41	69.00	2.65	52,635	150,341
DNS-75	75.00	71.33	5.08	2.41	72.00	2.65	54,828	156,605

¹ Add suffix "-S02" for 302 stainless steel, "-S16" for 316 stainless steel.

² Based on a groove material yield strength of 310 N/mm² and a safety factor of 2.

³ Based on a safety factor of 3.

⁴ See pages 126-127 for How to Order.

Stock Items available in carbon steel and 302 and 316 stainless steel.

Product Dimensions All dimensions are in millimeters unless otherwise specified.

Smalley Part Number ^{1,4}	Shaft Diameter	Ring			Groove		Thrust Capacity	
		Inside Diameter	Radial Wall	Thickness	Diameter	Width	Groove Yield (N) ²	Ring Shear (N) ³
DNS-77	77.00	73.33	5.08	2.41	74.00	2.65	56,290	160,782
DNS-78	78.00	74.33	5.08	2.41	75.00	2.65	57,021	162,870
DNS-80	80.00	75.81	6.05	2.41	76.50	2.65	68,231	167,046
DNS-82	82.00	77.81	6.05	2.41	78.50	2.65	69,936	171,222
DNS-85	85.00	80.80	6.35	2.91	81.50	3.15	72,495	214,309
DNS-88	88.00	83.80	6.35	2.91	84.50	3.15	75,054	221,873
DNS-90	90.00	85.80	6.35	2.91	86.50	3.15	76,759	226,915
DNS-95	95.00	90.80	6.35	2.91	91.50	3.15	81,024	239,522
DNS-98	98.00	93.79	6.35	2.91	94.50	3.15	83,583	247,086
DNS-100	100.00	95.79	6.35	2.91	96.50	3.15	85,288	252,128
DNS-102	102.00	97.29	6.73	3.89	98.00	4.15	99,422	343,778
DNS-105	105.00	100.28	6.73	3.89	101.00	4.15	102,346	353,889
DNS-108	108.00	103.25	6.73	3.89	104.00	4.15	105,270	364,000
DNS-110	110.00	105.23	6.73	3.89	106.00	4.15	107,220	370,741
DNS-115	115.00	110.19	6.73	3.89	111.00	4.15	112,093	387,593
DNS-120	120.00	115.16	6.73	3.89	116.00	4.15	116,967	404,445
DNS-125	125.00	120.12	6.73	3.89	121.00	4.15	121,840	421,297
DNS-130	130.00	125.07	6.73	3.89	126.00	4.15	126,714	438,149
DNS-135	135.00	130.02	6.73	3.89	131.00	4.15	131,588	455,001
DNS-140	140.00	134.98	6.73	3.89	136.00	4.15	136,461	471,852
DNS-145	145.00	139.93	6.73	3.89	141.00	4.15	141,335	488,704
DNS-150	150.00	143.91	7.92	3.89	145.00	4.15	182,761	505,556
DNS-155	155.00	148.89	7.92	3.89	150.00	4.15	188,853	522,408
DNS-160	160.00	153.85	7.92	3.89	155.00	4.15	194,945	539,260
DNS-165	165.00	158.80	7.92	3.89	160.00	4.15	201,037	556,112
DNS-170	170.00	163.75	7.92	3.89	165.00	4.15	207,129	572,964
DNS-175	175.00	168.73	7.92	3.89	170.00	4.15	213,221	589,815
DNS-180	180.00	173.69	7.92	3.89	175.00	4.15	219,313	606,667
DNS-185	185.00	178.66	7.92	3.89	180.00	4.15	225,405	623,519
DNS-190	190.00	183.59	7.92	3.89	185.00	4.15	231,497	640,371
DNS-195	195.00	188.54	7.92	3.89	190.00	4.15	237,589	657,223
DNS-200	200.00	193.54	7.92	3.89	195.00	4.15	243,681	674,075
DNS-205	205.00	197.54	11.18	4.86	199.00	5.15	299,727	863,214
DNS-210	210.00	202.54	11.18	4.86	204.00	5.15	307,038	884,268
DNS-220	220.00	212.47	11.18	4.86	214.00	5.15	321,659	926,376
DNS-230	230.00	222.40	11.18	4.86	224.00	5.15	336,280	968,484
DNS-240	240.00	232.33	11.18	4.86	234.00	5.15	350,900	1,010,592
DNS-250	250.00	242.24	11.18	4.86	244.00	5.15	365,521	1,052,700
DNS-260	260.00	250.19	12.70	4.86	252.00	5.15	506,856	1,094,808
DNS-270	270.00	260.15	12.70	4.86	262.00	5.15	526,351	1,136,916
DNS-280	280.00	270.08	12.70	4.86	272.00	5.15	545,845	1,179,024
DNS-290	290.00	279.98	12.70	4.86	282.00	5.15	565,340	1,221,132
DNS-300	300.00	289.92	12.70	4.86	292.00	5.15	584,834	1,263,241
DNS-310	310.00	297.84	15.88	5.87	300.00	6.20	755,411	1,576,625
DNS-320	320.00	307.84	15.88	5.87	310.00	6.20	779,779	1,627,484
DNS-330	330.00	317.75	15.88	5.87	320.00	6.20	804,147	1,678,342
DNS-340	340.00	327.69	15.88	5.87	330.00	6.20	828,515	1,729,201
DNS-350	350.00	337.64	15.88	5.87	340.00	6.20	852,883	1,780,060
DNS-360	360.00	347.57	15.88	5.87	350.00	6.20	877,251	1,830,919
DNS-370	370.00	357.48	15.88	5.87	360.00	6.20	901,619	1,881,778
DNS-380	380.00	367.41	15.88	5.87	370.00	6.20	925,987	1,932,637
DNS-390	390.00	377.34	15.88	5.87	380.00	6.20	950,355	1,983,496
DNS-400	400.00	387.25	15.88	5.87	390.00	6.20	974,723	2,034,354

¹ Add suffix "-S02" for 302 stainless steel, "-S16" for 316 stainless steel.

² Based on a groove material yield strength of 310 N/mm² and a safety factor of 2.

³ Based on a safety factor of 3.

⁴ See pages 126-127 for How to Order.

Stock Items available in carbon steel and 302 stainless steel.

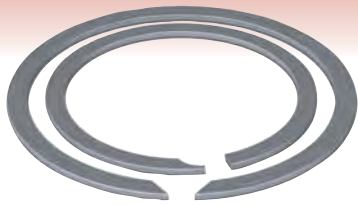

Groove Compatible with DIN 471

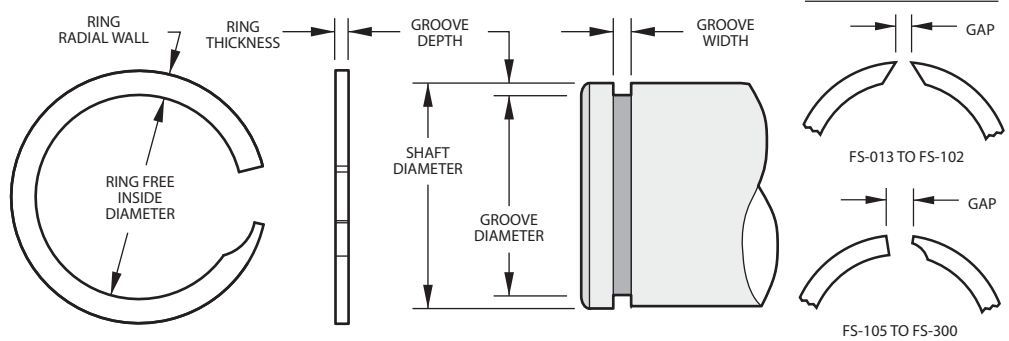

Product Dimensions All dimensions are in millimeters unless otherwise specified.

Smalley Part Number ^{1,4}	Shaft Diameter	Ring			Groove		Thrust Capacity	
		Inside Diameter	Radial Wall	Thickness	Diameter	Width	Groove Yield (N) ²	Ring Shear (N) ³
FS-013	13.00	12.27	1.40	.94	12.40	1.10	1,931	10,591
FS-014	14.00	13.31	1.40	.94	13.40	1.10	2,077	11,396
FS-015	15.00	14.15	1.40	.94	14.30	1.10	2,602	12,224
FS-016	16.00	14.98	1.65	.94	15.20	1.10	3,172	13,029
FS-017	17.00	16.06	1.65	.94	16.20	1.10	3,367	13,838
FS-018	18.00	16.82	1.90	1.15	17.00	1.30	4,457	17,953
FS-019	19.00	17.81	1.90	1.15	18.00	1.30	4,702	18,941
FS-020	20.00	18.80	1.90	1.15	19.00	1.30	4,951	19,928
FS-021	21.00	19.79	1.90	1.15	20.00	1.30	5,200	20,942
FS-022	22.00	20.83	1.90	1.15	21.00	1.30	5,445	21,930
FS-023	23.00	21.77	1.90	1.15	22.00	1.30	5,698	22,939
FS-024	24.00	22.50	2.15	1.15	22.90	1.30	6,539	23,927
FS-025	25.00	23.70	2.15	1.15	23.90	1.30	6,806	24,914
FS-026	26.00	24.64	2.15	1.15	24.90	1.30	7,082	25,929
FS-027	27.00	25.50	2.15	1.15	25.90	1.30	7,353	26,916
FS-028	28.00	26.32	3.25	1.44	26.60	1.60	9,702	33,179
FS-029	29.00	27.15	3.25	1.44	27.60	1.60	10,053	34,385
FS-030	30.00	28.35	3.25	1.44	28.60	1.60	10,395	35,559
FS-032	32.00	29.87	3.25	1.44	30.30	1.60	13,073	37,939
FS-033	33.00	31.07	3.25	1.44	31.30	1.60	13,478	39,113
FS-034	34.00	31.96	3.25	1.44	32.30	1.60	13,892	40,319
FS-035	35.00	32.57	3.25	1.44	33.00	1.60	16,899	41,493
FS-036	36.00	33.64	4.01	1.69	34.00	1.85	17,375	50,038
FS-038	38.00	35.62	4.01	1.69	36.00	1.85	18,344	52,827
FS-040	40.00	37.02	4.01	1.69	37.50	1.85	24,265	55,621
FS-042	42.00	39.08	4.01	1.69	39.50	1.85	25,484	58,410
FS-045	45.00	42.05	4.01	1.69	42.50	1.85	27,303	62,578
FS-046	46.00	43.10	4.01	1.69	43.50	1.85	27,904	63,952
FS-047	47.00	44.03	4.01	1.69	44.50	1.85	28,504	65,331
FS-048	48.00	44.89	4.01	1.69	45.50	1.85	29,118	66,741
FS-050	50.00	46.50	5.08	1.93	47.00	2.15	36,529	75,282
FS-052	52.00	48.48	5.08	1.93	49.00	2.15	37,974	78,266
FS-054	54.00	50.46	5.08	1.93	51.00	2.15	39,438	81,287
FS-055	55.00	51.45	5.08	1.93	52.00	2.15	40,163	82,777
FS-056	56.00	52.44	5.08	1.93	53.00	2.15	40,906	84,307
FS-058	58.00	54.42	5.08	1.93	55.00	2.15	42,352	87,287
FS-060	60.00	56.55	5.08	1.93	57.00	2.15	43,819	90,308
FS-062	62.00	58.32	5.08	1.93	59.00	2.15	45,283	93,328
FS-063	63.00	59.37	5.08	1.93	60.00	2.15	46,008	94,823
FS-065	65.00	61.35	5.08	2.41	62.00	2.65	47,471	116,641
FS-067	67.00	63.35	5.08	2.41	64.00	2.65	48,939	120,240
FS-068	68.00	64.45	5.08	2.41	65.00	2.65	49,660	122,019
FS-070	70.00	66.22	5.08	2.41	67.00	2.65	51,128	125,618
FS-072	72.00	68.28	5.08	2.41	69.00	2.65	52,591	129,221
FS-075	75.00	71.25	5.08	2.41	72.00	2.65	54,780	134,599

¹ Add suffix "-S02" for 302 stainless steel.

² Based on a groove material yield strength of 310 N/mm² and a safety factor of 2.

³ Based on a safety factor of 3.

⁴ See pages 126-127 for How to Order.

Stock Items available in carbon steel and 302 stainless steel.

Product Dimensions All dimensions are in millimeters unless otherwise specified.

Smalley Part Number ^{1,4}	Shaft Diameter	Ring			Groove		Thrust Capacity	
		Inside Diameter	Radial Wall	Thickness	Diameter	Width	Groove Yield (N) ²	Ring Shear (N) ³
FS-077	77.00	73.23	5.08	2.41	74.00	2.65	56,230	138,153
FS-078	78.00	74.06	5.08	2.41	75.00	2.65	56,968	139,977
FS-080	80.00	75.70	6.02	2.41	76.50	2.65	68,342	143,575
FS-082	82.00	77.68	6.02	2.41	78.50	2.65	70,033	147,134
FS-085	85.00	80.65	6.30	2.91	81.50	3.15	72,595	175,656
FS-088	88.00	83.60	6.30	2.91	84.50	3.15	75,175	181,906
FS-090	90.00	85.80	6.30	2.91	86.50	3.15	76,865	185,998
FS-095	95.00	90.68	6.30	2.91	91.50	3.15	81,140	196,340
FS-098	98.00	93.70	6.30	2.91	94.50	3.15	83,702	202,536
FS-100	100.00	95.50	6.30	2.91	96.50	3.15	85,415	206,682
FS-102	102.00	97.23	6.30	2.91	98.50	3.15	87,127	210,828
FS-105	105.00	99.83	6.73	3.89	101.00	4.15	102,687	276,951
FS-108	108.00	102.87	6.73	3.89	104.00	4.15	105,619	284,855
FS-110	110.00	104.90	6.73	3.89	106.00	4.15	107,580	290,149
FS-115	115.00	109.85	6.73	3.89	111.00	4.15	112,473	303,346
FS-120	120.00	115.06	6.73	3.89	116.00	4.15	117,344	316,478
FS-125	125.00	119.75	6.73	3.89	121.00	4.15	122,237	329,676
FS-130	130.00	124.70	6.73	3.89	126.00	4.15	127,130	342,873
FS-135	135.00	129.65	6.73	3.89	131.00	4.15	132,023	356,071
FS-140	140.00	134.42	6.73	3.89	136.00	4.15	136,916	369,269
FS-145	145.00	139.55	6.73	3.89	141.00	4.15	141,809	382,467
FS-150	150.00	143.50	8.03	3.89	145.00	4.15	181,986	395,665
FS-155	155.00	148.45	8.03	3.89	150.00	4.15	188,026	408,796
FS-160	160.00	153.40	8.03	3.89	155.00	4.15	194,094	421,994
FS-165	165.00	158.40	8.03	3.89	160.00	4.15	200,166	435,192
FS-170	170.00	163.30	8.03	3.89	165.00	4.15	206,237	448,683
FS-175	175.00	168.25	8.03	3.89	170.00	4.15	212,305	461,890
FS-180	180.00	173.20	8.03	3.89	175.00	4.15	218,377	475,097
FS-185	185.00	177.62	8.03	3.89	180.00	4.15	224,417	488,232
FS-190	190.00	183.35	8.03	3.89	185.00	4.15	230,489	501,439
FS-195	195.00	188.05	8.03	3.89	190.00	4.15	236,556	514,646
FS-200	200.00	193.00	8.03	3.89	195.00	4.15	242,628	527,853
FS-205	205.00	196.95	11.05	4.87	199.00	5.15	299,454	641,438
FS-210	210.00	201.67	11.05	4.87	204.00	5.15	306,763	657,096
FS-220	220.00	211.80	11.05	4.87	214.00	5.15	321,344	688,327
FS-230	230.00	221.70	11.05	4.87	224.00	5.15	335,961	719,638
FS-240	240.00	231.89	11.05	4.87	234.00	5.15	350,578	750,953
FS-250	250.00	241.50	11.05	4.87	244.00	5.15	365,199	782,264
FS-260	260.00	249.59	12.70	4.87	252.00	5.15	505,300	813,500
FS-270	270.00	259.30	12.70	4.87	262.00	5.15	524,748	844,811
FS-280	280.00	268.83	12.70	4.87	272.00	5.15	544,200	876,126
FS-290	290.00	279.10	12.70	4.87	282.00	5.15	563,599	907,357
FS-300	300.00	289.00	12.70	4.87	292.00	5.15	583,051	938,673

¹ Add suffix "-S02" for 302 stainless steel.

² Based on a groove material yield strength of 310 N/mm² and a safety factor of 2.

³ Based on a safety factor of 3.

⁴ See pages 126-127 for How to Order.

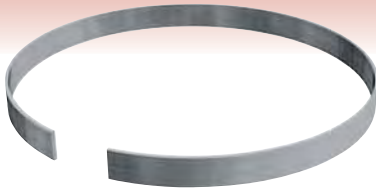

Stock Items available in carbon steel and 302 stainless steel.

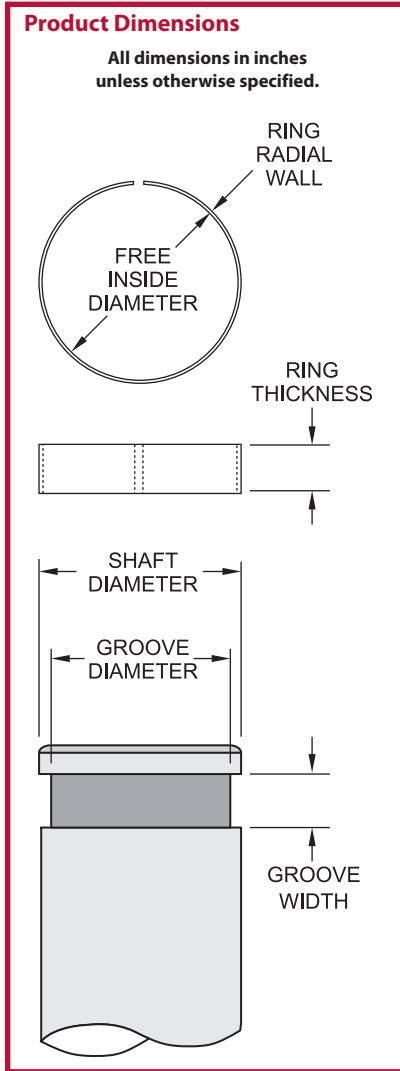

Smalley Part Number ^{1,3}	Shaft Diameter	Ring			Groove		Groove Yield (lb) ²
		Inside Diameter	Radial Wall	Thickness	Diameter	Width	
HS-37	.375	.351	.017	.045	.358	.050	225
HS-43	.437	.411	.017	.045	.420	.050	263
HS-46	.469	.443	.017	.045	.452	.050	282
HS-50	.500	.469	.021	.065	.479	.070	371
HS-53	.531	.499	.021	.065	.510	.070	394
HS-56	.562	.530	.021	.065	.541	.070	417
HS-59	.594	.561	.021	.065	.573	.070	441
HS-62	.625	.592	.021	.065	.604	.070	464
HS-65	.656	.622	.021	.065	.635	.070	487
HS-68	.688	.653	.021	.065	.667	.070	511
HS-71	.718	.680	.024	.088	.694	.093	609
HS-75	.750	.711	.024	.088	.726	.093	636
HS-78	.781	.741	.024	.088	.757	.093	662
HS-81	.812	.772	.024	.088	.788	.093	689
HS-84	.843	.802	.024	.088	.819	.093	715
HS-87	.875	.834	.024	.088	.851	.093	742
HS-90	.906	.864	.024	.088	.882	.093	768
HS-93	.938	.895	.024	.088	.914	.093	796
HS-96	.968	.925	.024	.088	.944	.093	821
HS-100	1.000	.956	.024	.088	.976	.093	848
HS-103	1.031	.980	.030	.118	1.001	.123	1,093
HS-106	1.062	1.011	.030	.118	1.032	.123	1,126
HS-109	1.093	1.041	.030	.118	1.063	.123	1,159
HS-112	1.125	1.073	.030	.118	1.095	.123	1,193
HS-115	1.156	1.103	.030	.118	1.126	.123	1,226
HS-118	1.188	1.134	.030	.118	1.158	.123	1,260
HS-121	1.218	1.164	.030	.118	1.188	.123	1,291
HS-125	1.250	1.195	.030	.118	1.220	.123	1,325
HS-128	1.281	1.225	.030	.118	1.251	.123	1,358
HS-131	1.312	1.252	.034	.150	1.278	.155	1,577
HS-134	1.343	1.282	.034	.150	1.309	.155	1,614
HS-137	1.375	1.314	.034	.150	1.341	.155	1,652
HS-140	1.406	1.344	.034	.150	1.372	.155	1,690
HS-143	1.437	1.374	.034	.150	1.403	.155	1,727
HS-146	1.468	1.405	.034	.150	1.434	.155	1,765
HS-150	1.500	1.436	.034	.150	1.466	.155	1,802
HS-156	1.562	1.497	.034	.150	1.528	.155	1,877
HS-162	1.625	1.559	.034	.150	1.591	.155	1,953
HS-168	1.688	1.619	.034	.150	1.653	.155	2,028
HS-175	1.750	1.677	.038	.187	1.712	.193	2,350
HS-181	1.812	1.739	.038	.187	1.775	.193	2,434
HS-187	1.875	1.800	.038	.187	1.837	.193	2,518
HS-193	1.938	1.861	.038	.187	1.900	.193	2,603
HS-200	2.000	1.922	.038	.187	1.962	.193	2,686
HS-206	2.062	1.983	.038	.187	2.024	.193	2,769
HS-212	2.125	2.045	.038	.187	2.087	.193	2,854
HS-218	2.188	2.106	.038	.187	2.150	.193	2,939
HS-225	2.250	2.167	.038	.187	2.212	.193	3,022
HS-231	2.312	2.228	.038	.187	2.274	.193	3,105
HS-237	2.375	2.290	.038	.187	2.337	.193	3,190
HS-243	2.437	2.343	.045	.225	2.392	.232	3,876
HS-250	2.500	2.405	.045	.225	2.455	.232	3,976
HS-256	2.562	2.466	.045	.225	2.517	.232	4,075
HS-262	2.625	2.528	.045	.225	2.580	.232	4,175
HS-268	2.688	2.589	.045	.225	2.643	.232	4,275
HS-275	2.750	2.650	.045	.225	2.705	.232	4,374
HS-281	2.812	2.712	.045	.225	2.768	.232	4,472
HS-287	2.875	2.773	.045	.225	2.830	.232	4,572
HS-293	2.938	2.833	.045	.225	2.892	.232	4,673
HS-300	3.000	2.895	.045	.225	2.955	.232	4,771

¹ Add suffix "-S02" for 302 stainless steel.

² Based on a groove material yield strength of 45,000 psi and a safety factor of 2.

³ See pages 126-127 for How to Order.

Stock Items available in carbon steel and 302 stainless steel.

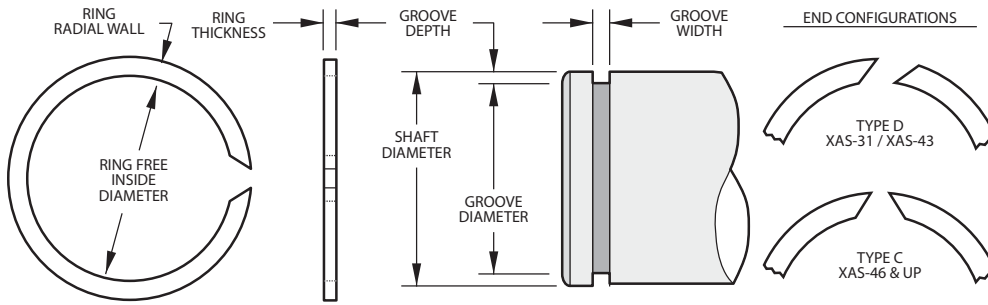

Product Dimensions All dimensions are in inches unless otherwise specified.

Smalley Part Number ^{1,4}	Shaft Diameter	Ring			Groove		Thrust Capacity	
		Inside Diameter	Radial Wall	Thickness	Diameter	Width	Groove Yield (lb) ²	Ring Shear (lb) ³
XAS-31	.312	.281	.040	.025	.290	.028	243	977
XAS-34	.344	.312	.040	.025	.322	.028	267	1,077
XAS-35	.354	.320	.040	.025	.330	.028	300	1,108
XAS-37	.375	.341	.040	.025	.351	.028	318	1,174
XAS-39	.393	.359	.040	.025	.369	.028	333	1,231
XAS-40	.406	.372	.040	.025	.382	.028	344	1,271
XAS-43	.438	.402	.040	.025	.412	.028	402	1,371
XAS-46	.469	.433	.040	.025	.443	.028	431	1,468
XAS-50	.500	.464	.048	.035	.474	.039	459	2,073
XAS-55	.551	.514	.048	.035	.524	.039	526	2,285
XAS-56	.562	.524	.048	.035	.534	.039	556	2,331
XAS-59	.594	.555	.048	.035	.566	.039	588	2,463
XAS-62	.625	.586	.062	.035	.597	.039	619	2,592
XAS-66	.669	.630	.062	.035	.640	.039	686	2,774
XAS-68	.688	.644	.062	.042	.656	.046	778	3,458
XAS-75	.750	.703	.062	.042	.716	.046	901	3,770
XAS-78	.781	.733	.062	.042	.745	.046	994	3,926
XAS-81	.812	.764	.062	.042	.776	.046	1,033	4,082
XAS-87	.875	.820	.078	.042	.835	.046	1,237	4,398
XAS-93	.938	.881	.078	.042	.896	.046	1,392	4,715
XAS-98	.984	.925	.078	.042	.940	.046	1,530	4,946
XAS-100	1.000	.941	.093	.042	.956	.046	1,555	5,027
XAS-102	1.023	.962	.093	.042	.977	.046	1,663	5,142
XAS-106	1.062	1.000	.093	.050	1.016	.056	1,727	6,272
XAS-112	1.125	1.060	.093	.050	1.075	.056	1,988	6,644
XAS-118	1.188	1.121	.093	.050	1.136	.056	2,183	7,017
XAS-125	1.250	1.179	.093	.050	1.194	.056	2,474	7,383
XAS-131	1.312	1.232	.093	.050	1.250	.056	2,875	7,749
XAS-137	1.375	1.291	.109	.050	1.309	.056	3,207	8,121
XAS-143	1.438	1.351	.109	.050	1.370	.056	3,456	8,493
XAS-150	1.500	1.408	.109	.050	1.430	.056	3,711	8,859
XAS-156	1.562	1.467	.125	.062	1.490	.068	3,975	11,002
XAS-162	1.625	1.527	.125	.062	1.551	.068	4,250	11,446
XAS-168	1.687	1.581	.125	.062	1.611	.068	4,531	11,882
XAS-175	1.750	1.640	.125	.062	1.670	.068	4,948	12,326
XAS-177	1.771	1.657	.141	.062	1.687	.068	5,258	12,474
XAS-181	1.812	1.698	.141	.062	1.728	.068	5,379	12,763
XAS-187	1.875	1.759	.156	.062	1.789	.068	5,699	13,206
XAS-196	1.969	1.849	.156	.062	1.879	.068	6,263	13,869
XAS-200	2.000	1.880	.156	.062	1.910	.068	6,362	14,087
XAS-206	2.062	1.936	.156	.078	1.966	.086	6,996	17,491
XAS-212	2.125	1.997	.156	.078	2.027	.086	7,360	18,025
XAS-215	2.156	2.026	.156	.078	2.056	.086	7,620	18,288
XAS-225	2.250	2.116	.156	.078	2.146	.086	8,270	19,085
XAS-231	2.312	2.174	.187	.078	2.204	.086	8,825	19,611
XAS-237	2.375	2.235	.187	.078	2.265	.086	9,233	20,145
XAS-243	2.437	2.295	.187	.078	2.325	.086	9,647	20,671
XAS-250	2.500	2.356	.187	.078	2.386	.086	10,073	21,206

¹ Add suffix "-S02" for 302 stainless steel.

² Based on a groove material yield strength of 45,000 psi and a safety factor of 2.

³ Based on a safety factor of 3.

⁴ See pages 126-127 for How to Order.

Stock Items available in carbon steel and 302 stainless steel.

Product Dimensions All dimensions are in inches unless otherwise specified.

Smalley Part Number ^{1,4}	Shaft Diameter	Ring			Groove		Thrust Capacity	
		Inside Diameter	Radial Wall	Thickness	Diameter	Width	Groove Yield (lb) ²	Ring Shear (lb) ³
XAS-255	2.559	2.413	.187	.078	2.443	.086	10,491	21,706
XAS-262	2.625	2.475	.187	.078	2.505	.086	11,133	22,266
XAS-268	2.687	2.535	.187	.078	2.565	.086	11,586	22,792
XAS-275	2.750	2.594	.187	.093	2.624	.103	12,246	27,992
XAS-287	2.875	2.713	.187	.093	2.743	.103	13,413	29,264
XAS-293	2.937	2.771	.187	.093	2.801	.103	14,117	29,895
XAS-300	3.000	2.830	.218	.093	2.860	.103	14,844	30,536
XAS-306	3.062	2.890	.218	.093	2.920	.103	15,367	31,167
XAS-312	3.125	2.951	.218	.093	2.981	.103	15,904	31,809
XAS-315	3.156	2.980	.218	.093	3.010	.103	16,285	32,124
XAS-325	3.250	3.070	.250	.093	3.100	.103	17,230	33,081
XAS-334	3.344	3.160	.250	.093	3.190	.103	18,201	34,038
XAS-343	3.437	3.251	.250	.093	3.281	.103	18,950	34,984
XAS-350	3.500	3.305	.250	.109	3.340	.120	19,792	40,017
XAS-354	3.543	3.346	.250	.109	3.381	.120	20,286	40,508
XAS-362	3.625	3.423	.250	.109	3.458	.120	21,396	41,446
XAS-368	3.687	3.482	.250	.109	3.517	.120	22,153	42,155
XAS-375	3.750	3.541	.250	.109	3.576	.120	23,061	42,875
XAS-387	3.875	3.657	.281	.109	3.697	.120	24,378	44,304
XAS-393	3.938	3.713	.281	.109	3.758	.120	25,052	45,024
XAS-400	4.000	3.771	.281	.109	3.816	.120	26,012	45,733
XAS-425	4.250	4.016	.281	.109	4.066	.120	27,638	48,592
XAS-437	4.375	4.141	.281	.109	4.191	.120	28,451	50,021
XAS-450	4.500	4.255	.312	.109	4.310	.120	30,218	51,450
XAS-475	4.750	4.495	.312	.109	4.550	.120	33,576	54,308
XAS-500	5.000	4.730	.312	.109	4.790	.120	37,110	57,167
XAS-525	5.250	4.970	.375	.125	5.030	.139	40,821	65,732
XAS-550	5.500	5.206	.375	.125	5.266	.139	45,486	68,862
XAS-575	5.750	5.446	.375	.125	5.506	.139	49,586	71,992
XAS-590	5.900	5.600	.375	.125	5.656	.139	50,880	73,870
XAS-600	6.000	5.687	.375	.125	5.746	.139	53,863	75,122
XAS-625	6.250	5.916	.437	.156	5.986	.174	58,316	94,130
XAS-650	6.500	6.151	.437	.156	6.226	.174	62,946	97,895
XAS-675	6.750	6.386	.437	.156	6.466	.174	67,752	101,660
XAS-700	7.000	6.621	.437	.156	6.706	.174	72,736	105,426
XAS-725	7.250	6.840	.500	.187	6.930	.209	81,996	124,330
XAS-750	7.500	7.090	.500	.187	7.180	.209	84,823	128,617
XAS-800	8.000	7.560	.500	.187	7.660	.209	96,133	137,191
XAS-850	8.500	8.050	.500	.187	8.160	.209	102,141	145,766
XAS-900	9.000	8.545	.500	.187	8.660	.209	108,149	154,340
XAS-925	9.250	8.800	.500	.187	8.910	.209	111,153	158,627
XAS-950	9.500	9.040	.500	.187	9.160	.209	114,158	162,915
XAS-1000	10.000	9.535	.500	.187	9.660	.209	120,166	171,489

¹ Add suffix "-S02" for 302 stainless steel.

² Based on a groove material yield strength of 45,000 psi and a safety factor of 2.

³ Based on a safety factor of 3.

⁴ See pages 126-127 for How to Order.

Stock Items available in carbon steel and 302 stainless steel.

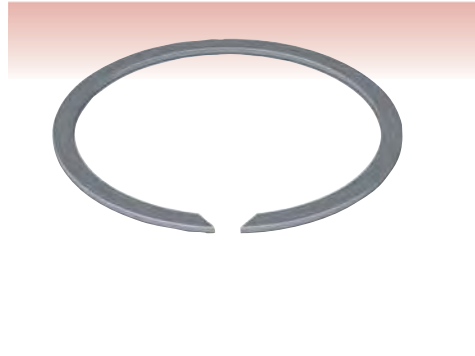
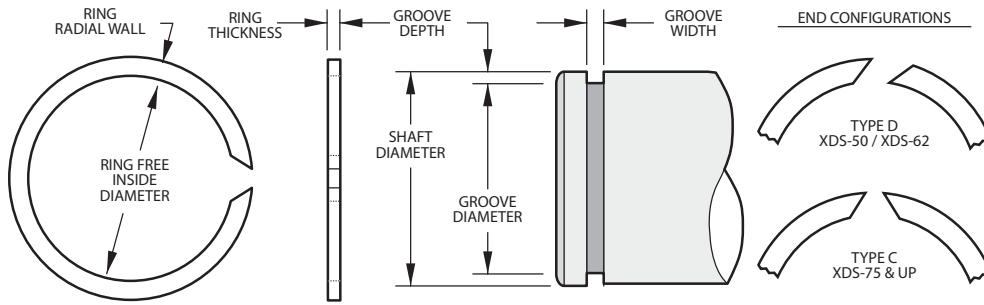

Product Dimensions All dimensions are in inches unless otherwise specified.

Smalley Part Number ^{1,4}	Shaft Diameter	Ring			Groove		Thrust Capacity	
		Inside Diameter	Radial Wall	Thickness	Diameter	Width	Groove Yield (lb) ²	Ring Shear (lb) ³
XDS-50	.500	.465	.048	.035	.474	.039	459	2,073
XDS-62	.625	.587	.062	.035	.597	.039	619	2,592
XDS-75	.750	.704	.078	.042	.716	.046	901	3,770
XDS-87	.875	.823	.093	.042	.833	.046	1,299	4,398
XDS-100	1.000	.944	.093	.042	.954	.046	1,626	5,027
XDS-112	1.125	1.065	.125	.042	1.077	.046	1,909	5,655
XDS-118	1.187	1.120	.125	.042	1.135	.046	2,182	5,967
XDS-125	1.250	1.179	.125	.042	1.194	.046	2,474	6,283
XDS-131	1.312	1.232	.125	.042	1.252	.046	2,782	6,595
XDS-137	1.375	1.289	.125	.042	1.309	.046	3,207	6,912
XDS-143	1.437	1.349	.125	.042	1.369	.046	3,454	7,223
XDS-150	1.500	1.410	.125	.042	1.430	.046	3,711	7,540
XDS-162	1.625	1.520	.156	.042	1.545	.046	4,595	8,168
XDS-168	1.687	1.582	.156	.042	1.607	.046	4,770	8,480
XDS-175	1.750	1.645	.156	.042	1.670	.046	4,948	8,796
XDS-193	1.937	1.832	.156	.042	1.857	.046	5,477	9,736
XDS-200	2.000	1.895	.156	.042	1.920	.046	5,655	10,053
XDS-218	2.187	2.082	.156	.042	2.107	.046	6,184	10,993
XDS-225	2.250	2.145	.156	.042	2.170	.046	6,362	11,310
XDS-237	2.375	2.270	.156	.042	2.295	.046	6,715	11,938
XDS-250	2.500	2.390	.156	.042	2.420	.046	7,069	12,566
XDS-275	2.750	2.596	.187	.062	2.626	.068	12,052	19,369
XDS-293	2.937	2.783	.187	.062	2.813	.068	12,871	20,687
XDS-300	3.000	2.846	.187	.062	2.876	.068	13,148	21,130
XDS-312	3.125	2.965	.187	.062	3.000	.068	13,806	22,011
XDS-325	3.250	3.090	.187	.062	3.125	.068	14,358	22,891
XDS-337	3.375	3.215	.187	.062	3.250	.068	14,910	23,772
XDS-350	3.500	3.340	.187	.062	3.375	.068	15,463	24,652
XDS-375	3.750	3.570	.218	.078	3.610	.086	18,555	31,809
XDS-400	4.000	3.820	.218	.078	3.860	.086	19,792	33,929
XDS-425	4.250	4.070	.218	.078	4.110	.086	21,029	36,050
XDS-450	4.500	4.320	.218	.078	4.360	.086	22,266	38,170
XDS-475	4.750	4.560	.218	.078	4.610	.086	23,503	40,291
XDS-500	5.000	4.800	.218	.078	4.860	.086	24,740	42,412
XDS-550	5.500	5.280	.250	.093	5.340	.103	31,102	55,983
XDS-600	6.000	5.775	.250	.093	5.840	.103	33,929	61,073
XDS-650	6.500	6.270	.250	.093	6.340	.103	36,757	66,162
XDS-700	7.000	6.765	.250	.093	6.840	.103	39,584	71,251
XDS-750	7.500	7.245	.281	.109	7.320	.120	47,713	85,750
XDS-800	8.000	7.740	.281	.109	7.820	.120	50,894	91,466

¹ Add suffix "-S02" for 302 stainless steel.

² Based on a groove material yield strength of 45,000 psi and a safety factor of 2.

³ Based on a safety factor of 3.

⁴ See pages 126-127 for How to Order.

Laminar Seal Rings

A Smalley Laminar Seal Ring is a metallic labyrinth seal consisting of multiple rings in a groove. This arrangement of the rings and the specific orientation of the rings are dictated by the application and the severity of the environment.

Applications:

- High Temperatures
- Heavy Splash Water
- Protects Against Grit/Dirt
- Protects Rubber Seals
- Standard Sizes:
 - 5/8" to 50"
 - 15 mm to 1,300 mm

Laminar Seal Rings Available From Stock

Standard parts from 5/8" to 50" and 15 mm to 1,300 mm. Special seals manufactured with No-Tooling-Charges. Smalley's Laminar Seal Rings are interchangeable with FEY Rings.



INTERCHANGE LISTING

SMALLEY	FEY	
QH	AS	
QHK	ASK	FK3
QS	IS	
QSK	ISK	
QHD	ASD	
QHKD	ASKD	FK6
QSD	ISD	
QSKD	ISKD	
CONSULT SMALLEY ENGINEERING		FK5

FOR MORE INFORMATION OR TO DOWNLOAD A CATALOG ON THIS SERIES, VISIT:
www.smalley.com/laminar

There are 16 series of STANDARD English & Metric Laminar Seal Ring configurations from which to select. Eight of these series are sets consisting of single-turn rings. The other 8 series are sets consisting of double-turn rings. Within each series are operational ring-set configurations in both English & Metric sizes. The selection of the appropriate set should be determined by the application. For some applications a complete labyrinth configuration (i.e.; a complete labyrinth configuration is one which has rings staggered within the set) is necessary due to a severe environment where contamination is highly probable. In other applications design engineers can keep the groove dimensions minimal by specifying laminar sets with rings clinging either to the bore or to the shaft.

Selection Guide Standard Laminar Ring Sets Available

Single-Turn Laminar Seal Rings

Used in a variety of applications, this series of Seal Rings should be utilized for light to medium duty applications, dependent on the ring configuration specified.

The sets are compromised of single-turn rings in either 3 rings per set or 5 rings per set.

APPLICATIONS: Three ring sets protect components from low dirt and low splash water contamination. Five ring sets provide a better labyrinth seal to protect components from medium dirt and medium splash water contamination.

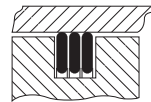

**YH Series
QH Series**
Internal - Light Duty
1 set = 3 individual rings
(rings rotate with bore only)

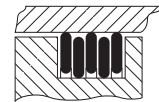

**YHK Series
QHK Series**
Internal - Medium Duty
1 set = 5 individual rings
(3 rings rotate with bore & 2 rings rotate with shaft)

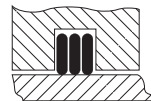

**YS Series
QS Series**
External - Light Duty
1 set = 3 individual rings
(rings rotate with shaft only)

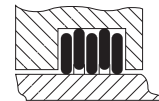

**YHK Series
QHK Series**
External - Medium Duty
1 set = 5 individual rings
(3 rings rotate with shaft & 2 rings rotate with bore)

Double-Turn Laminar Seal Rings

The sets are compromised of double-turn rings in either 2 rings per set or 3 rings per set. The double-turn rings fit tighter in the bore or on the shaft, provide complete 360° surface contact and resist higher axial/radial forces than single-turn ring sets, for medium to heavy duty applications.

APPLICATIONS: Two ring sets protect components from medium dirt and medium splash water contamination. Three ring sets provide a better labyrinth seal to protect components from heavy dirt and heavy splash water contamination.

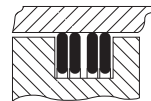

**YHD Series
QHD Series**
Internal - Medium/Heavy Duty
1 set = 2 individual rings
(rings rotate with bore only)

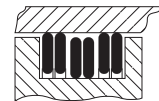

**YHKD Series
QHKD Series**
Internal - Heavy Duty
1 set = 3 individual rings
(2 rings rotate with bore & 1 rings rotate with shaft)

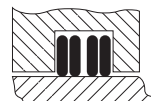

**YSD Series
QSD Series**
External - Medium/Heavy Duty
1 set = 2 individual rings
(rings rotate with bore only)



**YSKD Series
QSKD Series**
Internal - Heavy Duty
1 set = 3 individual rings
(1 rings rotate with bore & 2 rings rotate with shaft)

Custom-Made Rings & Springs

Custom For your Application

While Smalley has a large selection of stock retaining rings and wave springs to choose from, the uniqueness of applications often demands a ring or spring to conform to application-specific requirements. Our No-Tooling-Cost process provides an economical alternative, to produce a custom ring or spring to meet your exact specifications. Think of it as modifying a standard; change the diameter, material size, alloy or nearly any product characteristic to fit within your assembly. It's really a simple solution to get exactly what works best. At Smalley, specials are standard, as many of our accounts take advantage of getting exactly what works best. Retaining rings and wave springs are often the last design consideration in an assembly and commonly have to fit in restrictive spaces and need to provide critical operating characteristics. Having the ability to easily specify non-standard sizes, offers a preferred option designers will often follow.



Economical

A common misconception of special designs is the cost. Because of Smalley's unique manufacturing process, application-specific retaining rings or wave springs can be an economical solution for your unique needs. With Smalley's No-Tooling-Cost process we have the flexibility to quickly manufacture products of different diameter, thickness, material and finish at a minimal cost. This means that during the prototype stage we can produce alternative designs with no tooling modifications. It's not uncommon to produce one prototype for evaluation and subsequently make dimensional adjustments for a second single prototype. That's two setups, NO-TOOLING-CHARGES and a final product produced fast and economically.

Availability

Smalley is vertically integrated with onsite material manufacturing and a large warehouse. We are able to produce custom rings or springs using a wide variety of readily available materials, or can produce custom raw material sizes to meet delivery requirements. For customers who use just-in-time inventory control, Smalley will offer to stock parts for immediate shipment, ready for the next purchase order or blanket order release.

Lead Time

Whether you are looking for prototypes, short-runs or high volumes, Smalley's unique No-Tooling-Cost manufacturing process allows for special designs to be manufactured in a timely fashion. Since no special dies or forming tools are necessary for custom rings or springs, prototypes can be designed and produced in days, not weeks.

Engineering Support

Smalley specializes in the design, development and production of custom retaining rings and wave/compression springs. Our design engineers will tailor a design to meet the exact characteristics necessary for individual function, where certain criteria must be considered. For decades we've been doing exactly this at Smalley.

Smalley brings along the combined experience of our engineering staff in designing retaining rings and wave springs for the most demanding of applications. Our capabilities extend well beyond the ordinary manufacturer as we not only design the rings and springs, we design the machinery they run on. We have in-depth knowledge of mechanical assemblies, machining operations, fitting components, dynamics and a host of other elements in the diverse universe of mechanical components. Product Application Engineers have designed and solved thousands of tough applications for OEMs in nearly every industry. Whether it's exposure to high temperature or a cryogenic environment, a dynamic / fatigue problem or simply a static load, we've been involved and resolved complex design issues.

Smalley engineers establish the manufacturing processes needed. This includes primary coiling operations, secondary operations for special product features such as slots, tabs, holes, bends, hooks, joints, etc., plating and finishing, marking and other characteristics for most any feature required.

To develop a packaging solution, Smalley engineering has created standards with which solutions are offered for consideration. Whether the part is coin-wrapped, bulk packaged, wire tied, on a tube or individually bagged a Smalley engineer is involved with all aspects of handling and shipment.

Optimized Design

Smalley has developed sophisticated software that optimizes the variables in a given design. It considers both the dimensions of the product and the cost to produce the ring or spring. The typical analysis provides a product that performs to specification but does not over-design dimensions and/or materials that can raise costs. Because our No-Tooling-Cost process enables an almost infinite selection of dimensions, the software considers the relationships between maximum stress levels, product configurations and

dimensions, and pushes the limits in the choices available for the best design. Based upon the criteria selected, Smalley engineers work with you to best determine what design alternatives will work best for a particular application. By making simple design changes; such as material thickness, radial wall, number of waves or selecting a different alloy, we can quickly determine the design impact. This time saving technology allows for correct parts to be manufactured and ready to test.

Testing

In-house testing is performed on our products to ensure that they satisfy our stringent quality standards prior to shipment. Statistical Process Control, SPC, is performed on a sampling of parts to verify that critical dimensions are in control. Smalley has the ability to test various application-specific performance characteristics. An example would be cycle life.

Cross-Functional Teams

Housing both the manufacturing and office activities under one roof allows Smalley engineers to be involved in all aspects of support in the manufacturing process. From concept to production our engineers work with quality control, manufacturing, shipping and purchasing to ensure that the design and production process move efficiently and effectively.

Re-Engineering

If you are currently considering using Spirolox Retaining Rings or Smalley Wave Springs to replace an existing product, our engineering department will work with you to choose the best new design for your application. Send Smalley a sample of an existing ring or spring, drawings of the assembly or your design requirements and we will engineer and provide new solutions for your consideration. Once an alternative design is presented, engineering will work with you to obtain exact prototypes or samples of similar products for evaluation and testing.

Mid-Stream design changes can also be accomplished with relative ease. It is not uncommon that dimensions need modification right in the middle of production. Once again, Smalley products can usually be changed at any point in the process by making a machine adjustment, without any tooling changes. You can count on the flexibility Smalley products offer for all your applications.

Materials Table

The table below presents the more common alloys used by Smalley Steel Ring Company.

Material	Material Thickness (in)	Minimum Tensile Strength (psi)	Shear Strength (psi)	Maximum Recommended Operating Temp. ⁴ (°F)	Modulus of Elasticity (psi)
CARBON STEEL					
OIL TEMPERED SAE 1070 - 1090	.006 - .014	269,000	153,000	250	30 X 10 ⁶
	.0141 - .021	255,000	145,000		
	.0211 - .043	221,000	126,000		
	.0431 & larger	211,000	120,000		
HARD DRAWN SAE 1060 - 1075	.006 to .030	230,000	130,000		
	.0301 - .110	181,000	103,000		
	.1101 - .220	156,000	89,000		
AISI 302					
AMS-5866	.002 - .022	210,000	119,000	400	28 X 10 ⁶
	.0221 - .047	200,000	114,000		
	.0471 - .062	185,000	105,000		
	.0621 - .074	175,000	100,000		
	.0741 - .089	165,000	94,000		
	.0891 - .095	155,000	88,000		
AISI 316					
ASTM A313 1	.002 - .023	195,000	111,000	400	28 X 10 ⁶
	.0231 - .048	190,000	108,000		
	.0481 - .061	175,000	99,000		
	.0611 & larger	170,000	97,000		
17-7 PH/C					
CONDITION CH900 AMS-5529		240,000 ²	137,000 ²	650	29.5 X 10 ⁶
A-286					
AMS-5810		180,000 ²	105,000 ²	1000	31 X 10 ⁶
INCONEL⁵ Alloy X-750					
SPRING TEMPER AMS-5699 3 No. 1 TEMPER "Rc 35 MAXIMUM" AMS-5699 ^{1,3} No. 1 TEMPER AMS-5698		220,000 ²	125,000 ²	700	31 X 10 ⁶
		136,000 REF	77,000	700	
		155,000 ²	88,000 ²	1000	
INCONEL⁵ Alloy 718					
AMS-5596 ¹		180,000 ²	102,000 ²	1300	29.6 X 10 ⁶
ELGILOY⁵					
AMS-5876 ^{1,3}	.0043 - .025	280,000 ²	160,000 ²	800	30 X 10 ⁶
	.0251 - .047	255,000 ²	145,000 ²		
	.0471 - .075	205,000 ²	117,000 ²		
	.0751 - .100	160,000 ²	91,000 ²		
BERYLLIUM COPPER					
TEMPER TH02 ASTM B197 ¹		185,000 ²	128,000 ²	400	18.5 X 10 ⁶

NOTE: Additional materials available include Phosphor Bronze, C-276, 410 Stainless Steel, MONEL⁵ K-500, MONEL⁵ 400, Waspaloy and others. Please consult Smalley Engineering for further details.

¹ Referenced for chemical composition only.

² Values obtained after precipitation hardening.

³ Conforms to NACE Standard MR-01-75.

⁴ Exceeding these temperatures will cause increased relaxation. Consult Smalley Engineering for High Temperature applications.

⁵ ELGILOY is a registered trademark of Combined Metals of Chicago. INCONEL and MONEL are registered trademarks of Special Metals Corporation. HASTELLOY is a registered trademark of Haynes International.

Material Types

Selecting the proper material for an application requires a general knowledge of what is commonly available for use in Smalley flat wire products. Specifying the correct material can prevent additional cost and failure in operation. Carbon steel is the most commonly specified material. Stainless steels, although more costly than carbon steel, provide far superior corrosion resistance and have higher temperature operating limits.

Carbon Steel Oil Tempered

SAE 1070-1090 high carbon tempered spring steel is a standard material for spiral retaining rings and wave springs. Tensile strength and yield strength are maximized as a result of the oil tempered martensitic structure.

Hard Drawn

SAE 1060-1075 high carbon cold drawn spring steel is a standard material for snap rings. Hard drawn carbon steel has no scale as it receives its strength from the drawing process.

In either temper, carbon steel is best suited in applications having a protected environment as it corrodes if not lubricated or atmospherically sealed. Additional corrosion protection can be added with special finishes. Rings and springs are normally supplied with an oil dip finish providing protection during shipment and for shelf storage.

■ Carbon steel is highly magnetic and can be a variety of different colors including blue, black and gray.

Stainless Steel 302 Stainless Steel

302 is the standard stainless steel for spiral retaining rings. This widely used material is specified because of its combination of corrosion resistance and physical properties. 302 obtains its spring temper condition by cold working. Though it is categorized as being a nonmagnetic stainless, 302 becomes slightly magnetic as a result of cold working. It is not hardenable by heat treatment.

■ 302 has a silver-gray color.

316 Stainless Steel

Nearly identical in physical properties and heat resistance to 302, 316 provides additional corrosion resistance, particularly against pitting, due to its molybdenum chemical content. 316 is generally used in food, chemical and sea water applications.

316 shows less magnetism than 302. However, as with 302, magnetism increases as the wire is cold reduced. This stainless grade is also not hardenable by heat treatment.

■ 316 has a silver-gray color.

17-7 PH/C Stainless Steel

Similar in corrosion resistance to type 302, this alloy is used almost exclusively for wave springs, yet offers both high tensile and yield strengths for special ring applications. In fatigue and high stress applications, 17-7 out performs even the finest grade of carbon steel.

Spring properties are achieved by precipitation hardening Condition C to Condition CH-900. As a result, the material may be subjected to a temperature of 343°C without a loss of spring properties. 17-7 PH C/CH-900 exhibits magnetism similar to high carbon steel.

■ After precipitation hardening, 17-7 has a blue, brown or silver color as a result of open-air heat treatment, although atmosphere controlled heat treatment provides a bright color.

Material Types

Super Alloys Inconel X-750*

This nickel-chromium alloy is used most commonly in high temperature and corrosive environments. Two commonly specified tempers of Inconel are described below.

Most commonly, Inconel X-750 is precipitation heat treated to a spring temper condition. In this state, it has temperature resistance to 700°F. The National Association of Corrosion Engineers (NACE) approves this hard temper to specification MR-01-75 (Rc50 maximum) for spiral retaining rings and wave/compression springs.

#1 temper, which requires a longer heat treatment than spring temper, has a lower tensile strength but provides temperature protection to 1000°F.

Both spring temper and #1 temper may be heat treated in either an open air or atmosphere controlled furnace. Open air heat treatment may produce oxidation, which often results in a slight black residue. An atmosphere controlled environment eliminates oxidation and produces a component with no residue.

- Rings and springs manufactured from this grade of Inconel have a blue/silver-gray color and exhibit no magnetism.



A286 Alloy

In applications up to 1000°F, this alloy exhibits similar properties to Inconel X-750. Its spring temper condition is obtained by precipitation hardening. A286 may be heat treated similar to spring temper and #1 temper Inconel.

- This material exhibits no magnetism and has a blue/silver-gray color.

Elgiloy*

Known for its excellent resistance to corrosive environments and use at elevated temperatures, this relatively new spring material is now readily available from Smalley. Commonly used in oil industry applications, Elgiloy shows improved reliability over other NACE approved materials by resisting sulfide stress cracking. Additionally, Elgiloy is said to out perform “over 600% better than 17-7 PH in load retention at 650°F and provide over 100% more cycles (in fatigue resistance) than carbon steel, without breakage.”

- Elgiloy exhibits no magnetism and is blue-brown in color as a result of heat treatment.

Coppers Beryllium Copper Alloy #25

Normally specified in a hard temper, this alloy produces excellent spring properties due to a combination of low modulus of elasticity and high ultimate tensile strength. The alloy gains its physical properties by precipitation hardening. In contrast to other copper alloys, beryllium copper has the highest strength and offers remarkable resistance to loss of physical properties at elevated temperatures.

- Beryllium copper is nonmagnetic. Its electrical conductivity is about 2-4 times as great as phosphor bronze

Phosphor Bronze, Grade A

Phosphor bronze offers fair spring properties, fair electrical conductivity and is rated a step below beryllium copper in performance. It is purchased in a spring temper condition to maximize spring characteristics.

- Phosphor bronze is hardenable only by cold working. This material is also nonmagnetic.

*INCONEL X-750 is a registered trademark of Special Metals Corporation. ELGILOY is a registered trademark of Combined Metals of Chicago.

Material Finishes

Black Oxide

MIL-DTL-13924, Class 1

This finish provides a flat black finish. Black oxide is intended more for cosmetic appearance than for corrosion resistance.

Cadmium Plating

Cadmium Plate, AMS-QQ-P-416, Type I, Class 2,

Cadmium Plate w/Chromate Dip, AMS-QQ-P-416, Type II, Class 2

Cadmium plating is used on carbon steel to increase the corrosion resistance of the product. The process of cadmium plating spiral retaining rings is costly and subjects the ring to the possibility of hydrogen embrittlement. Smalley offers stainless steel as the preferable option to cadmium.

Oil Dip

This is the standard finish for all Smalley products produced from carbon steel. The oil provides resistance to corrosion in transport and normal storage. The oil dip finish should not be considered a permanent finish.

Passivation

AMS 2700, Method 1, Type 2, Class 3

Passivation is an optional cleaning operation for stainless steel. It provides a bright finish and increased corrosion resistance. Passivation dissolves iron particles and other substances, which have become imbedded in the surface of stainless steel during production. If not dissolved, these foreign particles could promote rusting, discoloration or even pitting.

In theory, the corrosion resistance of stainless steel is due to the thin, invisible oxide film that completely covers the surface of the ring and prevents further oxidation. Removing the contaminants prevents breaks in the oxide film for optimum corrosion resistance.

Zinc Phosphate

MIL-DTL-16232, Type Z, Class 2

This finish is sometimes referred to as "Parkerizing" and appears gray-black in color. The corrosion resistance of phosphate is superior to black oxide but inferior to cadmium plating or stainless steel. Phosphate can not be applied to stainless steel.

Vapor Degrease/Ultrasonic Clean

This is the standard cleaning and finish for all stainless steels. The process removes oil and other organic compounds from the material surface by use of a chlorinated solvent. The solvent effectively removes oil and grease from the exposed surfaces of the ring or spring. Ultrasonics are used in forcing the solvent to act between the turns of the ring.

Vibratory Deburr/Hand Deburr

Though all circumferential surfaces and edges of Spirolox Rings are smooth, sharp corners are always present on the gap ends due to the cut-off operation. To break the sharp corners, achieving a blended/smooth surface finish, rings may either be vibratory or hand deburred to meet your specifications.

Specifications

Federal, aerospace and other regulating agencies have prepared several specifications for sheet and strip materials, but few have been published for flat wire. Smalley procures its material to internally generated specifications. In addition to controlling tensile strength, rigid inspection procedures have been established to check for edge contour, physical imperfections, camber, cross-section and chemical composition.

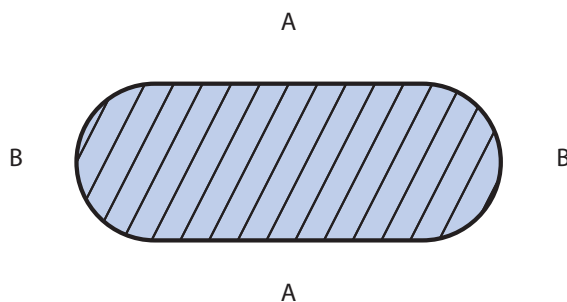

Ultimate Tensile Strength

To check the spring properties of wire, Ultimate Tensile Strength is the preferred test method over hardness because spring temper flat wire develops different hardnesses at various indentation points. As a result of cold rolling, the top and bottom surfaces ("A") become harder as they are more severely worked than the round edge areas ("B"). Tensile tests are more consistent as they evaluate the entire cross-section, not a single point as in a hardness test.



Spring Design Defining the Spring Requirements

Although wave spring applications are extremely diverse, there is a consistently basic set of rules for defining spring requirements. Those requirements are used to select a stock/standard spring or design a special spring to meet the specifications.

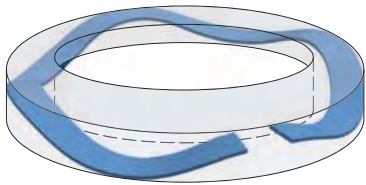

Working Cavity

The working cavity usually consists of a bore the spring operates in and/or a shaft the spring clears. The spring stays positioned by piloting in the bore or on the shaft. The distance between the loading surfaces defines the axial working cavity or work height of the spring.

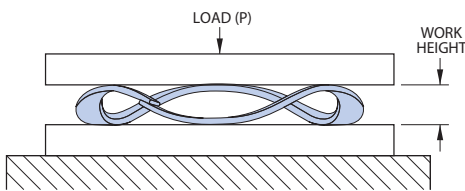

Load Requirement

The load requirement is defined by the amount of axial force the spring must produce when installed at its work height. Some applications require multiple working heights, where loads at 2 or more operating heights are critical and must be considered in the design. Often minimum and/or maximum loads are satisfactory solutions, particularly where tolerance stack-ups are inherent in the application.

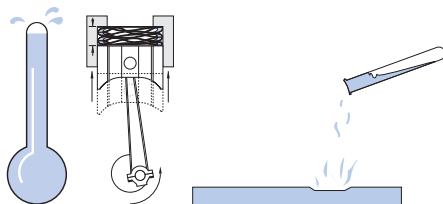

Operating Environment

High temperature, dynamic loading (fatigue), a corrosive media or other unusual operating conditions must be considered in spring applications. Solutions to various environmental conditions typically require selection of the optimal raw material and operating stress.

Standard Springs vs. Special Springs

Finding the right spring can be as easy as selecting a standard catalog item. A Smalley engineer can help you choose from over 4,000 standard parts available from stock in carbon and stainless steel. Smalley's "no-tooling" method of manufacturing provides the utmost in flexibility and quality. Whether the requirement is for 1 spring or 1,000,000 consider Smalley for your special spring requirements.

Let Smalley Design Your Spring

Over 50% of Smalley's business is in the design and manufacturing of special springs to suit individual applications. Whether it's a technical question, or the most complex spring design, Smalley engineers are always available and welcome the opportunity to assist you. Utilize the Application Checklist found in this catalog. Or at www.smalley.com we provide a simple procedure to e-mail us your known design parameters. An engineer will recommend a standard catalog item or provide you with design options for a special spring.

Spring Design

Nomenclature

b	Radial Width of Material, in [(O.D. - I.D.)÷2]	P	Load, lb
D _m	Mean Diameter, in [(O.D. + I.D.)÷2]	S	Operating Stress, psi
E	Modulus of Elasticity, psi	t	Thickness of Material, in
f	Deflection, in	WH	Work Height, in (H-f)
H	Free height, in	Z	Number of Turns
I.D.	Inside Diameter, in		
K	Multiple Wave Factor, see Table 1		
L	Length, Overall Linear, in		
N	Number of Waves (per turn)		
O.D.	Outside Diameter, in		

Multiple Wave Factor (K)

N	2.0-4.0	4.5-6.5	7.0-9.5	10.0 & Over
K	3.88	2.90	2.30	2.13

Table 1

Single Turn Gap or Overlap Type Applications

1. Low-Medium Force
2. Low-Medium Spring Rate
3. Short Deflection
4. Precise Load/Deflection Characteristics

Single turn wave springs are the basic and most common wave spring product. They are used in the widest variety of spring applications due to their lower cost and simplified design configuration.

Single turn wave springs provide the most flexibility to designers. There are few restrictions in their design. They are specified in the majority of small axial and radial space constraint applications.

Formulas:

$$\text{Deflection} = f = \frac{P K D_m^3}{E b t^3 N^4} * \frac{\text{I.D.}}{\text{O.D.}}$$

$$\text{Operating Stress} = S = \frac{3 \pi P D_m}{4 b t^2 N^2}$$

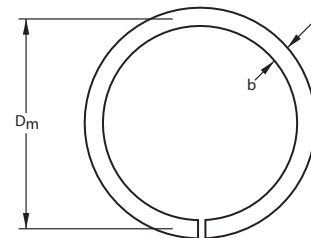

Crest-to-Crest (Series Stacked) Applications

1. Low-Medium Force
2. Low-Medium Spring Rate
3. Long Deflection
4. Precise Load/Deflection Characteristics

Crest-to-Crest flat wire compression springs are pre-stacked in series, decreasing the spring rate by a factor related to the number of turns.

Formulas:

$$\text{Deflection} = f = \frac{P K D_m^3 Z}{E b t^3 N^4} * \frac{\text{I.D.}}{\text{O.D.}}$$

$$\text{Operating Stress} = S = \frac{3 \pi P D_m}{4 b t^2 N^2}$$

Note: N must be in 1/2 wave increments
Z = Number of active turns

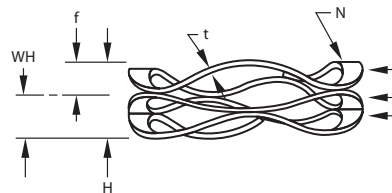
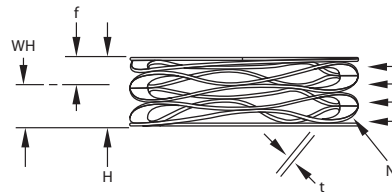

Nested Spirawave® (Parallel Stacked)

1. Higher Force
2. Higher Spring Rate
3. Short Deflection
4. Precise Load/Deflection Characteristics

Nested Spirawave Wave Springs are pre-stacked in parallel, increasing the spring rate by a factor related to the number of turns.

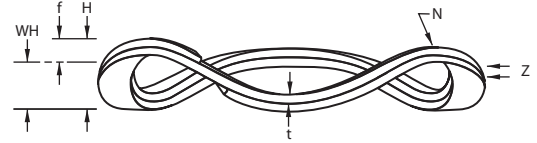

Formulas:

$$\text{Deflection} = f = \frac{P K D_m^3}{E b t^3 N^4 Z} * \frac{\text{I.D.}}{\text{O.D.}}$$

$$\text{Operating Stress} = S = \frac{3 \pi P D_m}{4 b t^2 N^2 Z}$$

Example: Smalley Part Number SSR-0200

Calculate free height and operating stress for Smalley part number SSR-0200 (Gap Type, Single Turn, Carbon Spring Temper Steel).

Where:

P = 34 lb	D _m = 1.835 in
t = .024 in	N = 4
b = .150 in	E = 30x10 ⁶ psi
O.D. = 1.985 in	K = 3.88
I.D. = 1.685 in	WH = .093 in

$$\text{Deflection} = f = \frac{(34)(3.88)(1.835)^3}{(30 \times 10^6)(.150)(.024)^3(4)^4} * \frac{1.685}{1.985} = .043 \text{ in}$$

$$\text{*Free Height} = H = (\text{W.H.} + f) = .093 + .043 = .136 \text{ in}$$

$$\text{Operating Stress} = S = \frac{(3)(\pi)(34)(1.835)}{(4)(.150)(.024)^2(4)^2} = 106,339 \text{ psi}$$

*Calculated free height may not be the same as the actual springs measure due to variations in raw material and manufacturing process.

Diameter Expansion

Nested & Crest-to-Crest Spirawaves Only: Multiple turn Spirawaves expand in diameter when compressed. The formula shown below is used to predict the maximum fully compressed diameter.

Formula: Maximum outside diameter at 100% deflection (solid height) = .02222 * R * N * θ + b

Where:

- R = Wave Radius = $(4Y^2 + X^2) \div 8Y$
 - N = Number of Waves
 - θ = Angle, degrees = $\text{ArcSin}(X \div 2R)$
 - b = Radial Wall
 - X = 1/2 Wave Frequency = $\pi D_m \div 2N$
 - Y = 1/2 Mean Free Height = $(H-t) \div 2$
- Where H = Per Turn Free Height

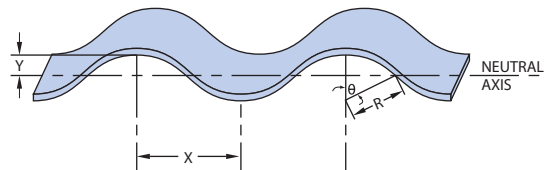

Linear Expanders

Linear Expanders are a continuous wave formed (marcelled) wire length produced from spring temper materials. They act as a load bearing device having approximately the same load/deflection characteristics as a wave spring.

Forces act axially or radially depending on the installed position. Axial pressure is obtained by laying the expander flat in a straight line. Circular wrapping the expander (around a piston for example) produces a radial force or outward pressure.

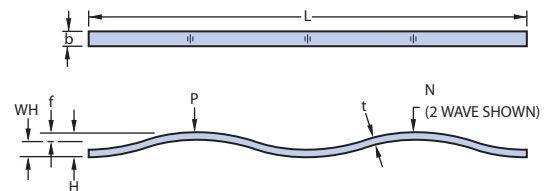

Formula: Single wave expander where N=1

$$\text{Deflection} = f = \frac{P L^3}{4 E b t^3} \quad \text{Operating Stress} = S = \frac{3 P L}{2 b t^2}$$

Formula: 2 or more wave expander where N>1

$$\text{Deflection} = f = \frac{P L^3}{16 E b t^3 N^4} \quad \text{Operating Stress} = S = \frac{3 P L}{4 b t^2 N^2}$$

Spring Design

Stress

Operating Stress

Compressing a wave spring creates bending stresses similar to a simple beam in bending. These compressive and tensile stresses limit the amount a spring can be compressed before it yields or “takes a set”. Although spring set is sometimes not acceptable, load and deflection requirements will often drive the design to accept some set or “relaxation” over time.

Maximum Design Stress

Static Applications Smalley utilizes the Minimum Tensile Strength found in this catalog’s Materials section to approximate yield strength due to the minimal elongation of the hardened flat wire used in Smalley products. When designing springs for static applications we recommend the calculated operating stress be no greater than 100% of the minimum tensile strength. However, depending on certain applications, operating stress can exceed the minimum tensile strength with allowances for yield strength. Typical factors to consider are permanent set, relaxation, loss of load and/or loss of free height.

Dynamic Applications When designing wave springs for dynamic applications, Smalley recommends that the calculation of operating stress not exceed 80% of the minimum tensile strength. Refer to the “Fatigue Stress Ratio” and Table 2 for further fatigue guidelines.

Residual Stress/Pre-Setting

Increasing the load capacity and/or fatigue life can be achieved by compressing a spring beyond its yield point or “presetting”. Preset springs are manufactured to a higher than needed free height and load and then compressed solid. Both the free height and load are reduced and the material surfaces now exhibit residual stresses, which enhance spring performance.

Fatigue

Fatigue cycling is an important consideration in wave spring design and determining precisely how much the spring will deflect can greatly impact the price of the spring. An analysis should include whether the spring deflects full stroke or only a few thousandths each cycle or possibly a combination of both as parts wear or temperature changes.

The fatigue guidelines in Table 2 provide a conservative approach and allow for calculation of cycle life between 2 work heights. Although these methods of fatigue analysis have proven to be a good approximation, testing is recommended whenever cycle life is critical.

Formula:

$$\text{Fatigue Stress Ratio} = X = \frac{(\sigma - S_1)}{(\sigma - S_2)}$$

(refer to Table 2)

Where: σ = Material tensile strength
 S_1 = Calculated operating stress at lower work height (must be less than σ)
 S_2 = Calculated operating stress at upper work height

Load/Deflection

A comparison of the actual spring rate to the theoretical (calculated) spring rate provides practical limits for the working range of the spring. Spring rate (P/f) can be calculated by manipulating the deflection equations. See formulas in the Spring Design section.

Figure 1 shows a graph of theoretical and tested spring rate. Typically, theoretical rate is accurate until the spring starts to bottom out or reach its “solid height”.

As a general rule, the calculated spring rate is linear through the first 80% of available deflection and for work heights down to 2 times the solid height. Although the spring can operate beyond this “linear” range, measured loads will be much higher than calculated.

Fatigue Guidelines	
X	Estimated Cycle Life
< .40	Under 30,000
.40 - .49	30,000 – 50,000
.50 - .55	50,000 – 75,000
.56 - .60	75,000 – 100,000
.61 - .67	100,000 – 200,000
.68 - .70	200,000 – 1,000,000
> .70	Over 1,000,000

Table 2

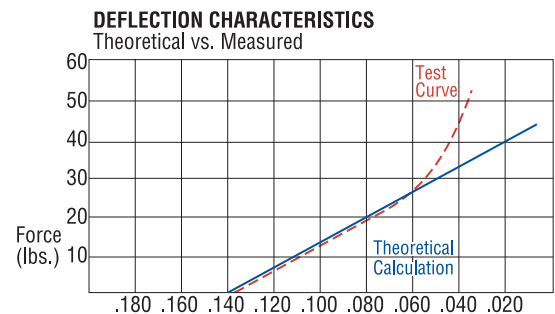

Figure 1

Hysteresis

Wave springs exert a greater force upon loading and lower force upon unloading. This effect is known as hysteresis. The shaded area shows a graphic representation between the curves in Figure 2.

In a single turn spring, friction due to circumferential and radial movements are the prime causes. Crest-to-Crest and Nested Springs also contribute to the frictional loss as adjacent layers rub against each other. Sufficient lubrication will minimize this effect.

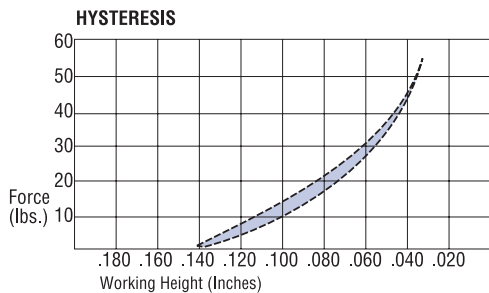

Figure 2

Design Guidelines

Material Cross-Section

Material cross-section plays an important role in wave spring design. The most economical materials are those used in manufacturing Smalley standard springs and retaining rings. In addition, many other material cross sections are commonly used in special spring manufacture designs. Smalley engineering can provide assistance in selecting an economical alloy and cross section.

As a basic guideline, use our standard 'SSR'-Wave Spring series for cross-section/diameter relationships. Lighter material sections are usually acceptable. Heavier sections for a given diameter may be incorporated using the following information:

Special wave spring design criteria for selecting material cross-sections:

- Maximum material thickness = standard ('SSR') thickness * 2
- Maximum radial wall = material thickness (any value) * 10
- Minimum radial wall = material thickness (any value) * 3

For Overlap Type Wave Springs and multiple turn Spirawaves, the radial wall must be sufficient to prevent misalignment between adjacent layers. For springs with a narrow radial wall, radial misalignment can occur during handling or during operation if the spring is not contained or closely piloted.

Solutions to this problem include dimensioning the spring to pilot closely on the I.D. and/or O.D. or designing the spring as a single turn Gap Type.

Diameters

Figure 3 illustrates two methods of specifying diameters. In either case, the spring diameter is developed to provide proper operation between the bore and the shaft.

Note: Smalley's manufacturing process of edgewinding controls either the O.D. or the I.D. The material radial wall is also tightly controlled. Therefore whenever possible, tolerance only one diameter and the radial wall instead of tolerancing both the O.D. and I.D.

Bore Pilot

For springs that pilot in the bore as shown in figure 3a, the bore and shaft diameters should be included in the spring specifications. Commonly used requirements would read:

"Spring must pilot and operate in a (minimum bore) bore diameter."

"Spring must clear a (maximum shaft) shaft diameter."

The actual spring diameter is then developed at time of manufacture to provide the best fit and prevent binding due to expansion.

For Gap Type and Overlap Type Springs, the outside diameter can be specified because binding is not a concern. The outside diameter can be toleranced to provide a minimum clearance in the bore or provide cling in the bore, as do the Smalley Bearing Preload Springs.

Shaft Pilot

For springs that pilot on a shaft as shown in Figure 3b, the inside diameter can be toleranced to provide a minimum clearance from the shaft. Since wave springs expand during compression, interference with the shaft is generally not a concern.

To insure proper operation, include shaft and bore diameters in the spring specifications. Commonly used requirements would read:

"Spring pilots over and clears a (maximum shaft) shaft diameter."

"Spring operates in a (minimum bore) bore diameter."

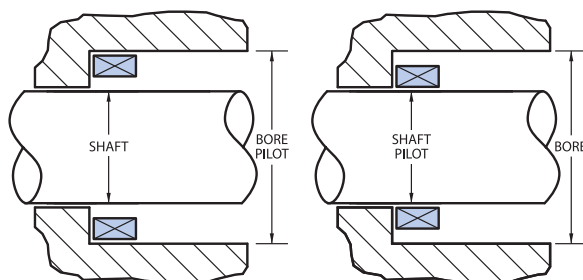

Figure 3a

Figure 3b

Engineering Support

Engineering Design

Spirolox Retaining Ring and Constant Section Ring applications, although diverse, can be analyzed with a straight forward set of design calculations. There are four main areas that should be considered in most applications.

1. Material Selection
2. Load Capacity
3. Rotational Capacity
4. Installation Stress

Smalley Application Engineers are available to provide immediate technical assistance.

The following pages of Spirolox Retaining Ring and Constant Section Ring engineering design have been developed from over 45 years of extensive testing and research into the various applications of retaining rings. The formulas are provided for the preliminary analysis of a ring application and the design of a Spirolox Retaining Ring.

Design engineers commonly associate the word "retaining ring" to a basic style or type of retaining device. In reality, retaining rings are nearly as diverse as their applications. Spirolox Retaining Rings offer a distinct alternative, and in many instances an advantage, over the more common retaining rings available on the market today. Some of the major distinctions are:

Spiral Wound in Multiple Turns

Increases load capacity yet allows easy assembly by hand or as an automated process.

360° Retaining Surface

No gap – no protruding ears.

Diameters from .200" to 120"

Uniform Radial Section

Provides a pleasant appearance on the assembled product. Beneficial when radial clearance is limited.

Simplified Assembly

Wind into groove. No special pliers/tools needed to install or remove. Removal notch provided for easy removal using a screwdriver.

Design Flexibility

Ring thickness can be changed to accommodate most any application by either varying material thickness and/or number of turns. Standard rings meet military and aerospace specifications. Special designs are produced quickly and economically in many alloys.

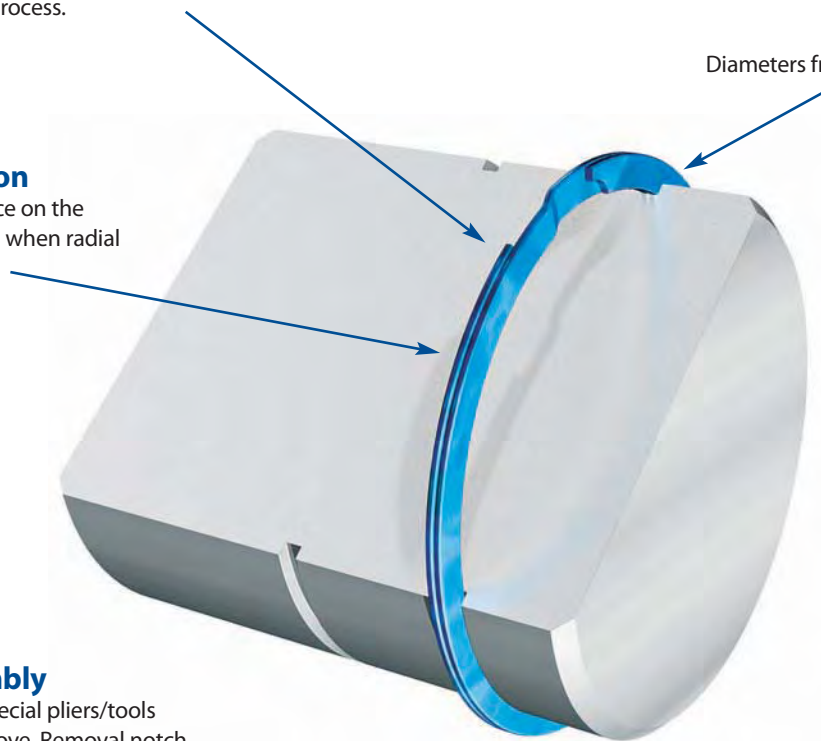

Load Capacity

Understanding the load capacity of a Spirolox Retaining Ring assembly requires calculations for both ring shear and groove deformation, with the design limitation being the lesser of the two.

The load capacity formulas do not take into account any dynamic or eccentric loading. If this type of loading exists, the proper safety factor should be applied and product testing conducted. In addition, the groove geometry and edge margin (i.e., the distance of the groove from the end of the shaft or housing) should be considered.

When abusive operating conditions exist, true ring performance is best determined through actual testing.

Ring Shear

Although not commonly associated as a typical failure of Spirolox Retaining Rings, ring shear can be a design limitation when hardened steel is used as a groove material. Ring thrust load capacities based on ring shear are provided within this catalog's tables of standard rings. These values are based on a shear strength of carbon steel with the recommended safety factor of 3.

Formula:

$$P_R = \frac{DT S_s \pi}{K}$$

Where:

- P_R = Allowable thrust load based on ring shear (lb)
- D = Shaft or housing diameter (in)
- T = Ring thickness (in)
- S_s = Shear strength of ring material (psi)
- K = Safety factor (3 recommended)

Example:

1. WH-550-S16
2. Safety factor = 3

$$P_R = \frac{5,500 (.072) 108,000 (\pi)}{3}$$

$$P_R = 44,787 \text{ lb}$$

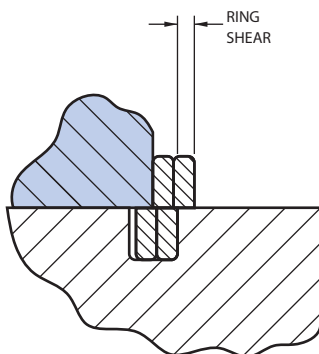

The thrust load based on ring shear above, must be compared to the thrust load based on groove deformation to determine which is the limiting factor in the design.

Groove Deformation (Yield)

Groove deformation is by far the most common design limitation of retaining rings. As permanent groove deformation occurs, the ring begins to twist. As the angle of twist increases, the ring begins to enlarge in diameter. Ultimately, the ring becomes dished and extrudes (rolls) out of the groove. As a conservative interpretation, the following equation calculates the point of initial groove deformation. This does not constitute failure which occurs at a much higher value. A safety factor of 2 is suggested. Ring thrust load capabilities based on groove deformation are provided within this catalog's tables of standard rings.

Formula:

$$P_G = \frac{D d S_y \pi}{K}$$

Where:

- P_G = Allowable thrust load based on groove deformation (lb)
- D = Shaft or housing diameter (in)
- d = Groove depth (in)
- S_y = Yield strength of groove material (psi), see Table 1
- K = Safety factor (2 recommended)

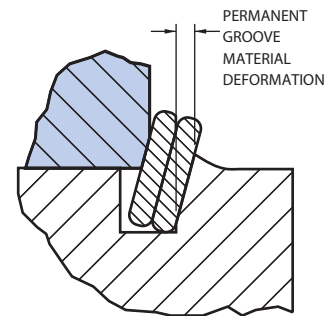

Example:

1. WH-550-S16
2. Groove material yield strength = 45,000 psi
3. Safety factor = 2

$$P_G = \frac{5,500 (.074) 45,000 (\pi)}{2}$$

$$P_G = 28,769 \text{ lb}$$

Typical Groove material yield strengths

Hardened Steel 8620	110,000 psi
Cold Drawn Steel 1018	70,000 psi
Hot Rolled Steel 1018	45,000 psi
Aluminum 2017	40,000 psi
Cast Iron	10-40,000 psi

Table 1

Since ring shear was calculated at 44,787 lb, the groove yields before the ring shears. Therefore 28,769 lb is the load capacity of the retaining ring.

Ring Design

Groove Geometry Groove Radius

To assure maximum load capacity it is essential to have square corners on the groove and retained components. Additionally, retained components must always be square to the ring groove in order to maintain a uniform concentric load against the retained part. The radius at the bottom of the groove should be no larger than Table 2 states.

Shaft or Housing Diameter	Maximum Radius on Groove Bottom
1 inch and under	.005 Max.
Over 1 inch	.010 Max.

Table 2

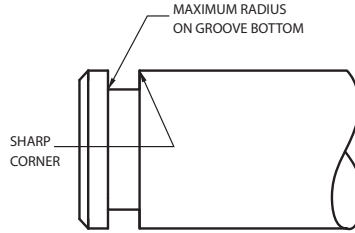

Retained Component

The retained part ideally has a square corner and contacts the ring as close as possible to the housing or shaft. The maximum recommended radius or chamfer allowable on the retained part can be calculated with the following formulas.

Where:

- b = Radial wall (in)
- d = Groove depth (in)

Example:

1. WH-100

Maximum Chamfer = $.375(.075-.021) = .020$ in

Maximum Radius = $.5(.075-.021) = .027$ in

Formula:

Maximum Chamfer = $.375(b - d)$
(on retained component)

Formula:

Maximum Radius = $.5(b - d)$
(on retained component)

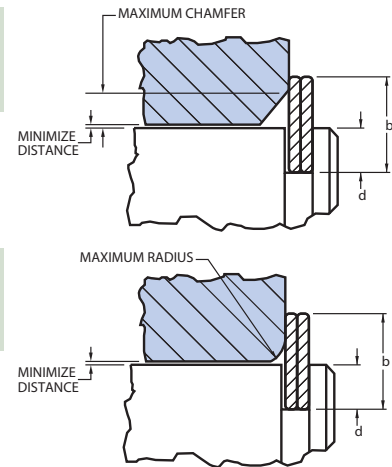

Edge Margin

Ring grooves which are located near the end of a shaft or housing should have an adequate edge margin to maximize strength. Both shear and bending should be checked and the larger value selected for the edge margin. As a general rule, the minimum edge margin may be approximated by a value of 3 times the groove depth.

Formula:

$$\text{Shear } z = \frac{K 3 P}{S_Y D_G \pi}$$

$$\text{Bending } z = \left[\frac{K 6 d P}{S_Y D_G \pi} \right]^{1/2}$$

Example:

1. VS-125

2. Groove material yield strength = 40,000 psi

3. Safety factor = 3

4. Load = 1000 lb

Where:

z = Edge margin (in)

P = Load (lb)

D_G = Groove diameter (in)

S_Y = Yield strength of groove material (psi), Table 1

d = Groove depth (in)

K = Safety factor (3 recommended)

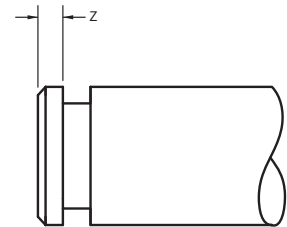

Shear

$$z = \frac{3 (3) 1000}{40,000 (1.206) \pi}$$

z = .059 in

Bending

$$z = \left[\frac{3 (6) .022 (1000)}{40,000 (1.206) \pi} \right]^{1/2}$$

z = .051 in

Therefore the minimum edge margin that should be used is .059 in

Rotational Capacity

The maximum recommended RPM for all standard external Spirolox Retaining Rings are listed in the ring tables of this manual.

A Spirolox Retaining Ring, operating on a rotating shaft, can be limited by centrifugal forces. Failure may occur when these centrifugal forces are great enough to lift the ring from the groove. The formula below calculates the RPM at which the force holding the ring tight on the groove (cling) becomes zero.

Rapid acceleration of the assembly may cause failure of the retaining ring. If this is a potential problem, contact Smalley engineering for design assistance.

Maximum RPM

Formula:

$$N = \left[\frac{3600 V E I g}{(4\pi^2) Y \gamma A R_M^5} \right]^{1/2}$$

- Where: N = Maximum allowable rpm (rpm)
- E = Modulus of elasticity (psi)
- I = Moment of inertia = $(t \times b^3) \div 12$ (in⁴)
- g = Gravitational acceleration (in/sec²), 386.4 in/sec²
- V = Cling $\div 2 = (D_G - D_I) \div 2$ (in)
- D_G = Groove diameter (in)
- D_I = Free inside diameter (in)
- Y = Multiple turn factor, Table 3
- n = Number of turns
- γ = Material density (lb/in³), (assume .283 lb/in³)
- A = Cross sectional area = $(t \times b) - (.12)t^2$ (in²)
- t = Material thickness (in)
- b = Radial wall (in)
- R_M = Mean free radius = $(D_I + b) \div 2$ (in)

n	1	2	3	4
Y	1.909	3.407	4.958	6.520

Table 3

Example:

1. WSM-150

$$V = (D_G - D_I) \div 2 = (1.406 - 1.390) \div 2 = .008 \text{ in}$$

$$I = (t \times b^3) \div 12 = (.024 \times .118^3) \div 12 = 3.29 \times 10^{-6} \text{ in}^4$$

$$A = (t \times b) - (.12)t^2 = (.024 \times .118) - .12(.024)^2 = .00276 \text{ in}^2$$

$$R_M = (D_I + b) \div 2 = (1.390 + .118) \div 2 = .754 \text{ in}$$

$$N = \left[\frac{3600 (.008) 30,000,000 (3.29 \times 10^{-6}) 386.4}{(4\pi^2) 3.407 (.283) .00276 (.754)^5} \right]^{1/2}$$

N = 6,539 rpm

Self-Locking

This feature allows the ring to function properly at speeds that exceed the recommended rotational capacity. The self-locking option can be incorporated for both external and internal rings. The self-locking feature utilizes a small tab on the inside turn "locking" into a slot on the outside turn. Self-locking allows the ring to operate at high speeds, withstand vibration, function under rapid acceleration and absorb a degree of impact loading.



Balanced

Smalley's balanced feature statically balances the retaining ring. A series of slots, opposite the gap end, account for the missing material in the gap. This characteristic is very useful when the balance of the assembly is critical and it is necessary to reduce eccentric loading.



Left Hand Wound

Smalley retaining rings are wound standard in a clockwise direction. In special applications it is sometimes favorable to have the retaining ring reverse, left hand wound.



Right Hand (Standard Wound)



Left Hand (Reverse Wound)

Installation Stress Analysis

The equations provided are used to check that the elastic stress limit of the ring material is not exceeded by stress due to installation. Standard parts that are assembled manually in the recommended shaft/bore and groove diameters do not require stress analysis. Special rings, or rings being assembled with special tooling, require stress analysis.

To select a safe stress value, it is necessary to estimate the elastic limit of the raw material. The minimum tensile strength, as shown in the materials table of the catalog, can be used as a suitable estimate. As with any theoretical calculation, a closer analysis of the actual application may reveal that these stress values can be exceeded. However, particular consideration must be made to functional characteristics such as installation method, the number of times the ring will be installed and removed, thrust load and/or centrifugal capacity.

After forming, the ring's natural tendency is to return to its original state. This places the inner edge of the radial wall in residual tension and the outer edge in residual compression. To account for the residual stress in the ring when expansion is taking place, only 80% of the minimum tensile strength should be used to compare to the installation stress; see Table 4.

In special designs, where the installation stress exceeds the material's elastic limit, rings can be produced to diameters which will yield a predetermined amount during assembly. Once installed, the ring will have the proper cling (grip) on the groove.

Installation Stress

Formula:

For external rings

$$S_E = \frac{E b (D_S - D_I)}{(D_I + b)(D_S + b)}$$

For internal rings

$$S_C = \frac{E b (D_O - D_H)}{(D_O - b)(D_H - b)}$$

Where:

- S_E = Stress due to expansion (psi)
- S_C = Stress due to compression (psi)
- E = Modulus of elasticity (psi)
- b = Radial wall (in)
- D_S = Shaft diameter (in)
- D_H = Housing diameter (in)
- D_I = Free inside diameter, minimum (in)
- D_O = Free outside diameter, maximum (in)

Application	Percent of Minimum Tensile Strength
Shaft	80%
Housing	100%

Table 4

Example: Compare theoretical installation stress to percent of minimum tensile strength.

1. WS-100-S02

$$S_E = \frac{28,000,000 (.075) (1.000 - .933)}{(.933 + .075)(1.000 + .075)}$$

$$S_E = 129,845 \text{ psi}$$

Minimum tensile strength of the ring material: 210,000 psi.

Using 80%, (Table 4), of 210,000 psi = 168,000 psi.

$$129,845 \text{ psi} < 168,000 \text{ psi}$$

Since the installation stress is less than 80% of the minimum tensile strength, permanent set is not expected.

End Configurations

Smalley offers 4 series of Eaton style snap rings from stock. Additional end types can be manufactured to meet your snap ring requirements. Inquire about the following end types:

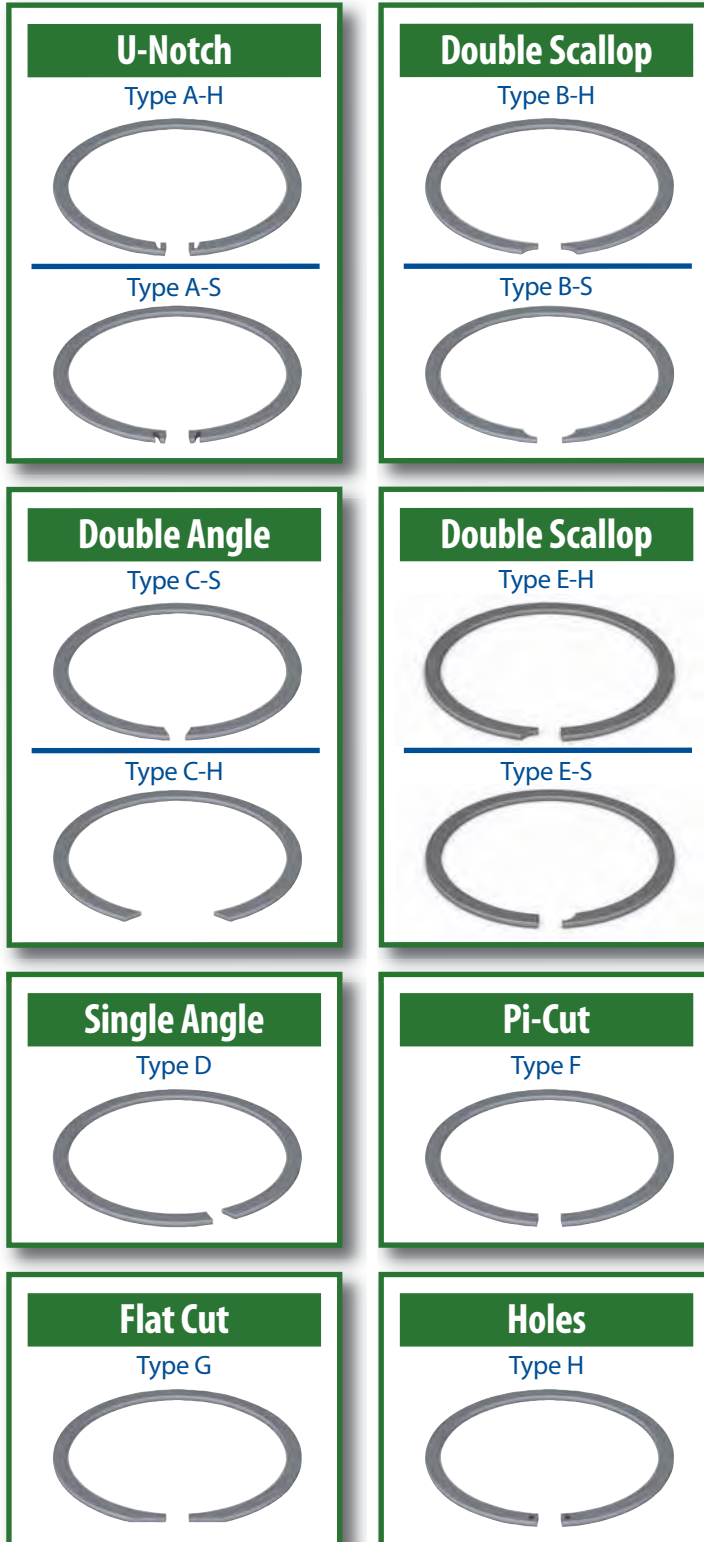

Material Hardness

Thickness (Inch)	Hardness (Rc) Min.
Up to .022	46.0
Over .022 to .050	44.0
Over .050 to .078	42.0
Over .078	40.0

Ring Abutment

Unlike a conventional Spiral Retaining Ring or Snap Ring, the retained component in a Hoopster® Retaining Ring* assembly may have a corner break. Thrust load is not sacrificed when the retained component has a broken corner because the moment arm is negligible in a Hoopster design.

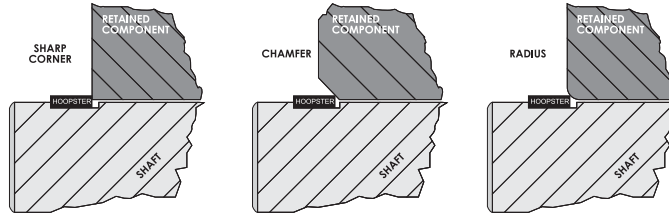

The 3 sketches above illustrate acceptable abutment practice.

Groove Design and Geometry

Groove deformation is by far the most common design limitation of most retaining rings. Unlike a conventional retaining ring or snap ring that fails by deforming and twisting, the Hoopster Retaining Ring shows superior strength from its low profile and mechanical advantage over traditional retaining rings under load. With a Hoopster, there is no moment arm that twists the ring causing premature failure as with a conventional retaining ring.

The shallow groove specification of a Hoopster makes the groove wall a critical specification, to ensure the function of the ring. To obtain maximum load capacity from a Hoopster Retaining Ring, it is essential to have sharp corners on the groove. The maximum radius on the groove bottom should be no greater than 10% of the ring's radial wall. Maintaining a sharp corner on the top of the groove is just as critical.

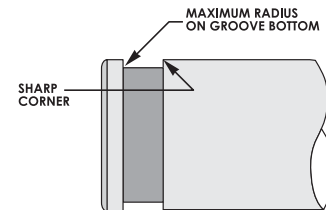

Formula: Maximum Radius on Groove Bottom = .10b

Where: b = Ring radial wall

Thrust Capacity

The shallow groove depth associated with a Hoopster, in combination with the groove material, are the controlling factors in determining thrust capacity. The Hoopster does not twist when loaded so pure thrust load based on the yield strength of the groove material maximizes the Hoopster's load carrying capacity.

Formula:

$$P_G = \frac{D d S_y \pi}{K}$$

Where:

- P = Allowable thrust load based on groove deformation (lb)
- D = Shaft or housing diameter (in)
- d = Groove depth (in)
- S_y = Yield strength of groove material (psi)
- K = Safety factor (2 recommended)

Typical Groove Material Yield Strengths

Hardened Steel 8620	110,000 psi
Cold Drawn Steel 1018	70,000 psi
Hot Rolled Steel 1018	45,000 psi
Aluminum 2017	40,000 psi
Cast Iron	10-40,000 psi

Table 5

*PATENT PENDING

www.smalley.com

Smalley's website is an interactive useful tool designed to help engineers and buyers find the product information needed. Here is a small sample of the resources available:

Product Search

With numerous different product lines, it can be difficult to find the standard part that is best for an application. To simplify the selection of stock items, utilize Smalley's search tools.

Retaining Ring Search: www.smalley.com/retaining_rings/search_for_a_ring.asp	Wave Spring Search: www.smalley.com/wave_springs/search_for_a_spring.asp
	
<p>Smalley has over 6,000 retaining rings to select from. Searching for the right ring is easy. Simply enter the application parameters and a list of corresponding rings will be presented to select from. A ring search allows the user to view the dimensions of all the rings for comparison.</p>	<p>Selecting the appropriate wave spring for an application can be a challenge. To simplify the process and differentiate between 4,000 stock springs is easy. By searching online, only the springs that fit a particular application will be presented. This makes it easy to see the variety of spring configurations available.</p>

Online Design

To simplify the design process and assist with the selection and design of spiral retaining rings and wave springs, a number of tools are available to assist with part selection, designing a special and receiving design assistance.

Engineering Specs

With the complete dimensions of all standard parts available online, it is simple to view the specifications of the stock items applied to your application.

Retaining Ring Example: Modify the groove material to match your assembly and calculate the new thrust capacity.

Wave Spring Example: Substitute your actual work heights and generate the new loads and cycle life for a standard spring.

Design Your Own Ring or Spring

Smalley's website offers users the ability to configure their own retaining ring or wave spring. Enter the application requirements to design a custom part that can be manufactured to your specifications. Change the material, the operating cavity and the wire properties to see how your design is affected. Print or submit your design directly to Smalley to verify that your design will work. This useful tool can be found at:

Retaining Ring Design: www.smalley.com/retaining_rings/design_a_special.asp

Wave Spring Design: www.smalley.com/wave_springs/design_a_special.asp

Design Assistance

If you would like Smalley's assistance in specifying a retaining ring or wave spring for your application, simply fill out an application checklist and specify the known parameters. Smalley will work with you to determine if a stock item can be provided or if a special design is required. Requests can be submitted online or print the application checklist and fax it back to us.

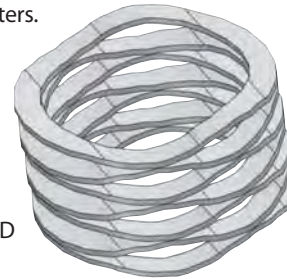

CAD Downloads

Standard retaining rings and wave springs are available for download in all major CAD systems. Once a part number has been selected an option to download a CAD model is presented. After a few simple steps, the model is available for direct download. This powerful CAD tool simplifies the design process by allowing engineers to drop Smalley parts right into any application.

With recently expanded capabilities, it is simple to adjust the operating heights of a wave spring model. Download a spring at either its posted work height, free height or enter a height at which the spring is expected to operate.

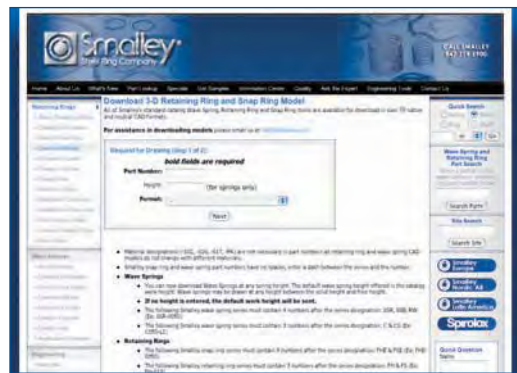

Request FREE Samples

Requesting samples to test in an application could not be easier. At www.smalley.com/samples, or on page 130 of this catalog, free samples of any standard catalog item can be requested at any time. Sample requests can be submitted and processed in 24 hours.

Additional Information

Assembly Information:

www.smalley.com/retaining_rings/installation_and_removal.asp

Detailed information on the various methods of assembling spiral retaining rings for high volume and low volume production is provided; includes both automated and manual assembly methods and an 18 page assembly brochure (www.smalley.com/pdfs/spiral_retaining_ring_install_and_removal.pdf).

Smalley News:

www.smalley.com/whats_new/whats_new.asp

As new products and applications are developed, Smalley's website is regularly updated with the latest information. Stay up to date with Smalley and find out What's New and how Smalley products are continuously evolving to meet new manufacturing standards.

Ask the Expert:

www.smalley.com/ask_the_expert/ask_the_expert.asp

Do you have a question that you would like to ask our staff? Questions submitted through "Ask the Expert" are routed directly to the appropriate department and will be promptly answered within 1 business day.

Smalley's engineering department provides free design consultation. Engineers are available to assist with part selection, custom designs, application requirements, materials, and more.

Get Catalog:

www.smalley.com/getcatalog

Need a new catalog or want to make sure you have the latest information? Smalley will promptly send out a copy of our latest catalog. Additionally, a PDF copy of Smalley's latest catalog is always available for download.

Springs Checklist

Application Checklist Custom Orders...Our Specialty

Fax to: 847.719.5999

Smalley Wave Springs

Quick Delivery on Custom Orders • No-Tooling-Cost • Precise Specifications • Engineering/Design Assistance
Complete this application checklist and challenge Smalley's Engineering staff.

Name _____ Title _____ Date _____

Company _____

Address _____

City/State/Zip Code _____ Country _____

Phone _____ Fax _____

Email _____

Dimensions In: () Standard Units () Metric Units

Operates in _____ bore diameter

Inside diameter clears _____ shaft

Specify which diameter the spring should pilot closest to:

() Bore () Shaft

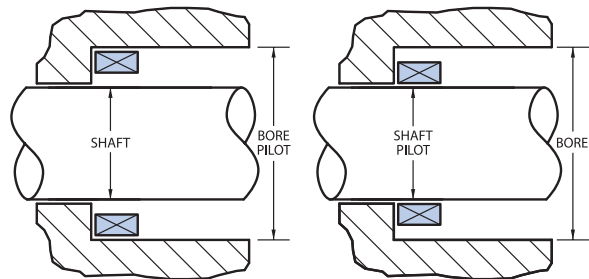

Load Deflection (Select One)

Group A

Min - Max Load @ Work Height () lb @ in () N @ mm

Free Height _____ Approximate

Group B

Min - Max Load @ Work Height () lb @ in () N @ mm

Min - Max Load @ Work Height () lb @ in () N @ mm

Free Height _____ Approximate

Group C

Free Height _____ (min) — _____ (max)

of Waves _____ Material Thickness _____

Radial Wall _____

Sketch

Material

Consider the environment:

Temperature _____ °
() F () C

Corrosive Media _____

*Carbon Steel ()

*17-7 PH/C Stainless ()

302 Stainless Steel ()

316 Stainless Steel ()

Inconel X-750 ()

Other _____ ()

Finish

* Oil dipped ()
(Carbon Steel)

* Vapor degreased ()
and ultrasonic cleaned
(Stainless Steel)

Passivate ()

Black Oxide ()

Phosphate Coat ()

Vibratory Deburr ()

Other _____ ()

Fatigue: Specify estimated cycle life

() Static Application () 10⁶ Cycle Life

() Under 10⁵ Cycle Life () Over 10⁶ Cycle Life

() 10⁵ Cycle Life

Quantity: Prototype _____

Production _____

Application: (Description)

*Denotes standard material or finish.

Application Checklist

Custom Orders...Our Specialty

Fax to: 847.719.5999

Rings Checklist

Quick Delivery on Custom Orders • No-Tooling-Cost • Precise Specifications • Engineering/Design Assistance
Complete this application checklist and challenge Smalley's Engineering staff.

Name _____ Title _____ Date _____
 Company _____
 Address _____
 City/State/Zip Code _____ Country _____
 Phone _____ Fax _____
 Email _____

Dimensions In: () Standard Units () Metric Units

Housing Diameter _____
 Shaft Diameter _____
 Groove Diameter _____
 Groove Width _____
 RPM _____

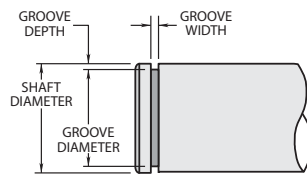

Ring Radial Wall _____

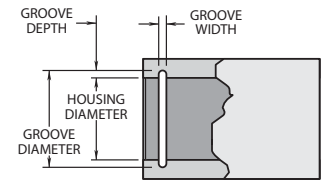

Ring Thickness _____

Thrust Capacity

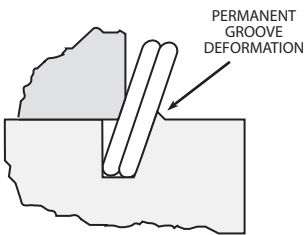

1. Groove Deformation

Occurs when maximum capacity is limited by the groove material (groove material is soft)

If thrust is a consideration specify:

Groove Material _____

Load Capacity _____ () lb () N

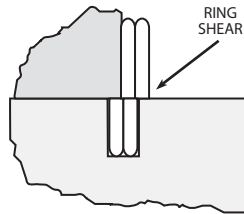

2. Ring Shear

Occurs when maximum capacity is limited by the retaining ring (groove material is hardened)

Material

Consider the environment:
 Temperature _____ °
 () F () C
 Corrosive Media _____
 *Carbon Steel ()
 *302 Stainless Steel ()
 *316 Stainless Steel ()
 Inconel X-750 ()
 A-286 ()
 Other _____ ()

Finish

* Oil dipped ()
 (Carbon Steel)
 * Vapor degreased ()
 and ultrasonic cleaned
 (Stainless Steel)
 Passivate ()
 Black Oxide ()
 Phosphate Coat ()
 Vibratory Deburr ()
 Other _____ ()

Quantity: Prototype _____
 Production _____

Application: (Description)

Sketch

*Denotes standard material or finish.

How To Order

Specifying Smalley Part Numbers

Smalley ring and spring part numbers consist of three steps. Please use the following guide to correctly identify your part number:

WHT-50-PA-S02

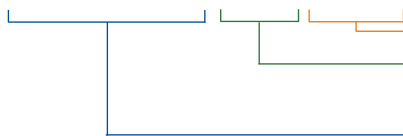

Step 3 Material: Specifies type of material (see Table 3)

Step 2 Finish: Specifies the type of finish to be applied on the material (see Table 2)

Step 1 Base Part Number: Specifies series and housing/shaft diameter (see Tables 1a & 1b)

Step 1: Base Part Numbers

Select Series...

TABLE 1a: Retaining Ring Series

SERIES	# TURNS	INTERNAL	EXTERNAL
Light Duty	1	VH	VS
Light Duty*	1	VHM	VSM
Medium Duty	2	WH	WS
Medium Heavy Duty	2 or 3	WHT	WST
Heavy Duty	2	WHM	WSM
Constant Section	1	FHE	FSE
Constant Section (Eaton Style)	1	XAH	XAS
Constant Section (Eaton Style)	1	XDH	XDS
Aerospace*	2	EH	ES
DIN Series*	2	DNH	DNS
Constant Section*	1	FHE	FS
Hoopster	1	HH	HS
WaveRing	2	WHW	WSW

* Metric Series

TABLE 1b: Wave Spring Series

SERIES	PREFIX
Standard Single-Turn	SSR
Bearing Preload*	SSB
Narrow Section Single-Turn	SSR-N
Shim	SSRS
Crest-to-Crest	C
Crest-to-Crest with Shim End	CS
Crest-to-Crest*	CM
Crest-to-Crest with Shim End*	CMS
Wavo	RW

* Metric Series

Then Specify Part Diameter

See the product tables for a complete listing of available diameters in stock. Below are some base part number examples:

WH-100	1.000" Medium Duty Internal Ring
WSM-150	1.500" Heavy Duty External Ring
C150	1.500" Crest-to-Crest Wave Spring
CS125	1.250" Crest-to-Crest Wave Spring w/ Shim Ends
RW-0237	2.375" Wavo Spring

2 Step 2: Finish

To prevent corrosion, carbon steel has an oil dip finish. Stainless steel parts are vapor degreased and go through an ultrasonic cleaning process. To specify a special finish on retaining rings or wave springs add the appropriate suffix to the part number preceding the material suffix. For standard materials, there is no designation necessary.

TABLE 2: Finish

STANDARD	
Finish	Designation
Carbon Steel — Oil Dip	None
Stainless Steel — Vapor Degrease & Ultrasonic Clean	None

SPECIAL	
Finish	Designation
Passivation	PA
Black Oxide	BA
Phosphate Coat	PS
Cadmium Plate	CD
Vibratory Deburr	DV

Example: WH-100-**PA**-S02 1.000" Medium Duty Housing Ring, with **passivation** in 302 stainless steel

3 Step 3: Material

To specify the material, add the appropriate designation below to the end of the part number.

TABLE 3: Material

STANDARD	
Finish	Designation
Carbon Steel SAE 1070-1090	None
302 Stainless Steel (Retaining Rings)	S02
316 Stainless Steel (Retaining Rings)	S16
17/7 PH C/CH900 Stainless Steel (Wave Springs)	S17

SPECIAL	
Finish	Designation
Inconel X-750	INX
A286	A86
Beryllium Copper	BEC
Phosphor Bronze	PHB
Elgiloy	LGY

Examples: VH-50 0.500" Light Duty Housing Ring in **Carbon Steel**
 VS-100-**S02** 1.000" Light Duty Shaft Ring in **302 Stainless Steel**
 C050-M5-**INX** 0.500" Crest-to-Crest Wave Spring in **Inconel X-750**

Note: Custom wave springs can be manufactured in 302 & 316 stainless steel, retaining rings can be manufactured in 17-7 PH C/CH900 stainless steel upon request.

Packaging

Smalley has the flexibility to package retaining rings and wave springs using a variety of methods to simplify your assembly process. Standard packaging is based on the diameter. As a general rule for both retaining rings and wave springs:

- 1 $\frac{5}{16}$ " and under diameters are bulk packaged.
- 1 $\frac{3}{8}$ " and over diameters are generally tube (coin) packaged in lengths 10" to 18".

Placing An Order

Smalley customer service representatives are available to assist you and guide you through the ordering process. For standard catalog rings and springs, Smalley's customer service department can assist with pricing, ordering and delivery information. Contact Smalley customer service at:

847.719.5900

847.719.5999

sales@smalley.com

Glossary

Bore Diameter: (See housing diameter)

Centrifugal Capacity (N): A mathematical expression for determining the speed (in revolutions per minute, rpm) at which a retaining ring will loose cling on the groove.

Cling: A value that signifies the amount of “interference fit” between a retaining ring and its groove.

Crest-To-Crest: Term used to identify a Smalley Flat Wire Compression spring in a “Series” configuration, having a sinusoidal waveform. The wave contour in each 360° turn provides a peak to valley relationship that decreases spring rate proportionally to the number of turns.

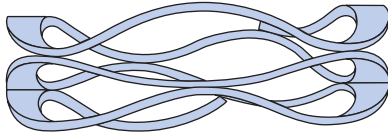

Dish: This ring dimension is the height difference in the ring cross section's axis of symmetry between O.D. and I.D. as illustrated below:

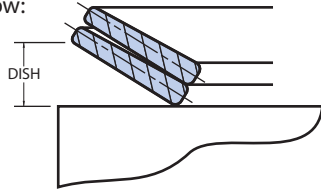

Edgewinding: Smalley's manufacturing method of circle coiling rectangular section flat wire on edge.

Free Gap: The distance between the “Free Ends” of a ring or spring as it rests in its free state.

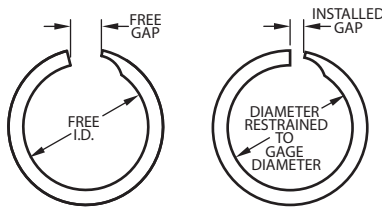

Hardness: The resistance of a material to plastic deformation, usually by indentation.

Helix: (see pitch)

Hoopster: Term used to identify the style of retaining ring with minimal radial projection and shallow groove depth.

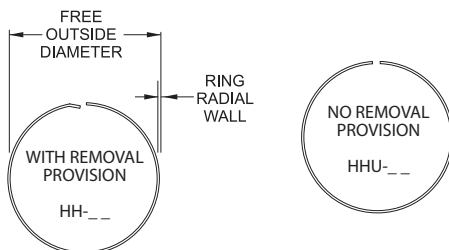

Housing Diameter (D_H): Also referred to as “bore” diameter. This dimension represents the inside diameter of the assembly where an internal retaining ring is installed.

Hydrogen Embrittlement: A condition where hydrogen is absorbed within the internal grain structure of metal tending to make it susceptible to cracking and failure, particularly under sustained loads. Environments such as hydrogen sulfide (H₂S) or processes such as electroplating or pickling can induce hydrogen embrittlement.

Installed Gap: (see Free Gap) This ring dimension is the distance between the ring ends while the ring is restrained at a specific gage diameter. Recommended as a more precise method of control over a free gap.

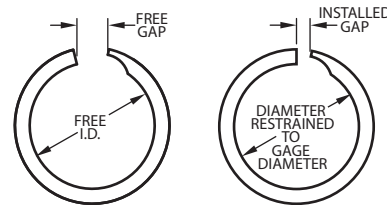

Installation Stress (S_C) or (S_E): Mathematical expression based on a radial strain. Useful in determining how far a Spirolox Retaining Ring can be expanded or contracted during installation.

Keystone: Derived from the definition of a “wedge” shaped stone. This term, illustrated below, refers to the “wedge” shaped cross section as a result of edgewinding flat wire.

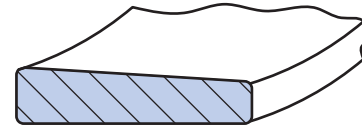

Left Hand Wound: Also referred to as “reverse wound”, design term signifying the counter-clockwise winding direction of a pitched coil.

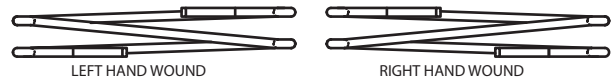

Linear Expander: Term used to identify a straight length of flat wire having a sinusoidal waveform. Used as a compression spring in both axial and radial applications.

Material Thickness (t): Also referred to as “wire” thickness. This dimension, as illustrated below, is useful in determining the overall ring thickness.

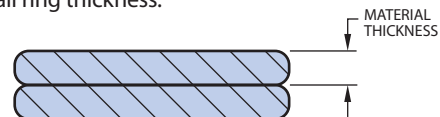

Misalignment: Also referred to as “skew”, this ring dimension is the radial variance of a multiple turn retaining.

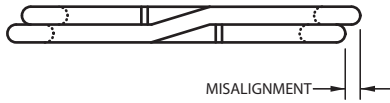

Modulus of elasticity (E): A measure of the rigidity of a material.

Nested: Term used to identify a Smalley Flat Wire Compression Spring in a “Parallel” configuration, having a sinusoidal waveform. The wave contour in each 360° turn matches (nests), increasing the spring rate proportionally to the number of turns.

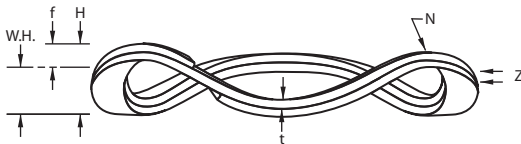

Number of Turns (n): The number of 360° turns of flat wire formed in a retaining ring or wave spring.

Offset: As illustrated below, this design feature is a bend in the material at the gap. This provides flat and parallel surfaces for ease of installation.

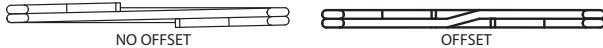

Permanent Set: A ring that has been expanded or contracted to a point where its elastic properties have been exceeded and does not return to its original diameter is said to have taken “permanent set”.

Pi-Cut Ends: Term signifying a particular ring design where the ends have been cut in an angular direction from the center of the ring as illustrated below.

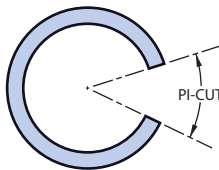

Pitch: Also referred to as helix, this ring dimension is the distance between two adjacent layers of the retaining ring.

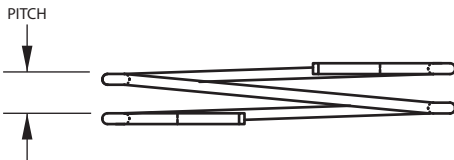

Radial Wall (b): Width of a retaining ring when measured from inside to outside edge.

Radius Notch: (see Removal Notch)

Removal Notch: Also referred to as a “radius notch” or “scallop”, this standard Spirolox Retaining Ring design feature is used to facilitate removal of the ring from its groove by means of a screwdriver or similar type tool.

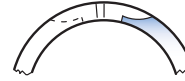

Residual Stress: Stress induced by a cold working process such as edgewinding. It may or may not be beneficial, depending upon the application.

Reverse Wound: (see left hand wound)

Right Hand Wound: Design term signifying the clockwise direction that a Spirolox Retaining Ring is normally wound. (also see Left Hand Wound)



Ring Thickness (T): Total thickness of an edgewound retaining ring. It may be determined by multiplying the material thickness by the number of turns and adding in the keystone value.

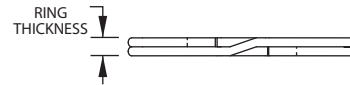

Rod Diameter: (see shaft diameter)

Safety Factor (K): Mathematical constant used in many design formulas to account for theoretical inaccuracies.

Scallop: (see Removal Notch)

Shaft Diameter (D_S): This dimension represents the outside diameter of the assembly where an external retaining ring is installed.

Shear Strength (S_J): An index of the quality of a material through a mathematical expression which divides the force required to shear a material by its cross-sectional area.

Stress Relieve: Low temperature heat treatment for removing any residual stresses induced by edgewinding and/or forming.

Tensile Strength: An index of the quality of a material through a mathematical expression which divides the material's load capacity in tension by its original cross-sectional area. Particularly accurate for spring steels, as there is only a small difference between ultimate tensile strength and yield strength.

Thrust Load Capacity (P_G) or (P_R): Overall capacity of an assembly to withstand a given value of thrust load in pounds. The limitation being the lesser of two mathematical calculations: ring thrust load capacity (P_R) or groove thrust load capacity (P_G).

Yield Strength (S_y): The stress at which a material exhibits initial plastic deformation.

WAVO: Single turn round wire wave spring.



Sample Request Form

Smalley Steel Ring offers **free** samples of catalog retaining rings, constant section rings and wave springs to test in your application.

FAX OR EMAIL NOW!
847.719.5999 • info@smalley.com

Shipping Address

Telephone number required for samples

Name _____
Company _____
Address _____
City/State/Zip Code _____ Country _____
Phone _____ Fax _____
Email _____

Shipping Method

All samples are sent out by US Mail. For expedited delivery, please provide a valid UPS or FedEx account number and specify the service to bill. Please call Smalley at 847.719.5900 to request other delivery methods.

- Regular US Mail:** *(free)*
- UPS:** Account number for charges *(required)* _____
 Ground Overnight 2nd Day
- FedEx:** Account number for charges *(required)* _____
 Overnight 2nd Day

Specific Sample

Please provide us with the part number you would like to test and the requested material:

Smalley Part Number: _____ Carbon Steel Stainless Steel
Smalley Part Number: _____ Carbon Steel Stainless Steel

Assorted Samples

- Please send me a sample bag of assorted Smalley retaining rings and wave springs.

Smalley reserves the right to authorize all sample requests.

Spirolox® Retaining Rings

No Ears To Interfere®

free samples • free CAD models

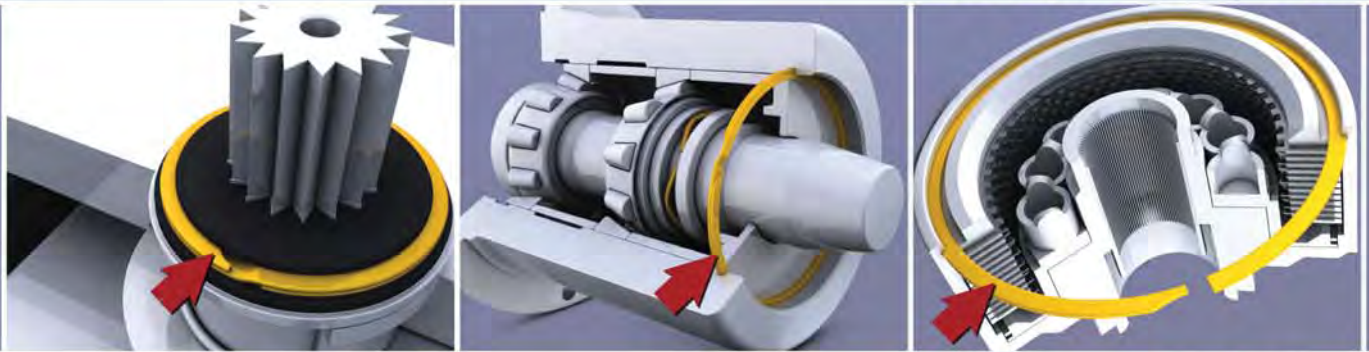

Spirolox Rings
Exclusively from
Smalley

COMPATIBLE WITH STAMPED RETAINING RING GROOVES

- Uniform cross-section does not interfere with the assembly
- Allows for tight radial applications
- Exotic alloys available: Inconel, Elgiloy, Titanium and more

STAINLESS STEEL FROM STOCK

- 6,000 stock sizes in carbon and stainless steel (302 & 316)
- Available from 1/4" to 16" diameters from stock
- No-Tooling-Costs™ on specials; available from .200" to 120"



www.smalley.com



Smalley®
Steel Ring Company

www.smalley.com/getcatalog • info@smalley.com
Lake Zurich, IL • 847.719.5900 • Fax: 847.719.5999

WAVE SPRINGS



- Reduces spring operating height by 50%
- Wave Springs save space
- Fits tight radial and axial spaces
- 4,000 stock sizes in carbon and stainless steel
- No-Tooling-Charges™ on special designs



RETAINING RINGS



- No protruding ears to interfere with assembly
- No gap allows for 360° retaining surface
- No special tools required for removal
- 6,000 stock sizes in carbon and stainless steel
- No-Tooling-Charges™ on special designs

SMALLEY®	SPIROLOX® SERIES	MILITARY MIL-DTL-27426	AEROSPACE AS3219	METRIC AEROSPACE MA 4035	EUROPEAN SPECIFICATION DIN	WALDES TRUARC	EATON	INDUSTRIAL RETAINING RING	OTHER RINGS	ANDERTON
VH	UR	---	---	---	---	---	---	---	---	---
VS	US	---	---	---	---	---	---	---	---	---
WH	RR	/3	AS4299 AS3217	---	---	---	---	---	---	---
WS	RS	/1	AS4299 AS3218	---	---	---	---	---	---	---
WHT	RRT	---	---	---	---	---	NAN	---	UHB	---
WST	RST	---	---	---	---	---	XAN	---	USC	---
WHM	RRN	/4	AS4299 AS3215	---	---	N5000 5008	IN	3000 4000	HO HOI UHO	N1300
WSM	RSN	/2	AS4299 AS3216	---	---	5100 5108	EN	3100 4100	SH SHI USH	N1400
DNH	---	---	---	---	DIN 472	---	---	---	DHO	D1300
DNS	---	---	---	---	DIN 471	---	---	---	DSH	D1400
EH	---	---	---	MA 4017	---	---	---	---	---	---
ES	---	---	---	MA 4016	---	---	---	---	---	---
FH	---	---	---	---	DIN 472	---	---	---	DHO	D1300
FS	---	---	---	---	DIN 471	---	---	---	DSH	D1400
XAH	---	---	---	---	---	---	NAN	---	UHB	---
XAS	---	---	---	---	---	---	XAN	---	USC	---
XDH	---	---	---	---	---	---	ND	---	HN	---
XDS	---	---	---	---	---	---	XD	---	SNL	---
XNH	---	---	---	---	---	---	IN	---	UHO	---
XNS	---	---	---	---	---	---	EN	---	USH	---

Groove Interchange Only
Use a Smalley Retaining Ring to fit into the same groove of these stamped Retaining Rings (circlips).



Smalley Steel Ring Company

(Corporate Headquarters)

555 Oakwood Road
Lake Zurich, IL 60047
USA

Phone: 1 847 719 5900
Fax: 1 847 719 5999
Email: info@smalley.com



Smalley Europe

46, avenue des Frères Lumière
78190 Trappes
France

Phone: +33 130 131 575
Fax: +33 130 131 576
Email: europe@smalley.com



Smalley Nordic AB

Box 653
SE - 441 18 Alingsås
Sweden

Phone: +46 322 611 770
Fax: +46 322 611 777
Email: nordic@smalley.com

Smalley WORLDWIDE

Smalley provides customized global supply chain solutions, to meet your WORLDWIDE manufacturing requirements, in Europe, Asia Pacific and the America's.