



More Precision

Color sensors colorSENSOR
LED Analyzers colorCONTROL



COLOR RECOGNITION SENSORS LED ANALYZERS

MICRO-EPSILON Eltrotec has 40 year's experience in the development and use of color recognition sensors and optical fiber technology.

In production and quality assurance, a number of very different types of color sensor are responsible for high productivity and cost reduction.

The sensors record color values, intensities and functions, and do so on various surfaces and self-luminous objects.

The very latest color sensors and high quality optical fibers are combined in a comprehensive product range.

They are used where high efficiency and effectiveness are called for.

Numerous renowned customers worldwide rely on accurate color recognition sensors from Micro-Epsilon Eltrotec and their production benefits from cost efficiency and information.

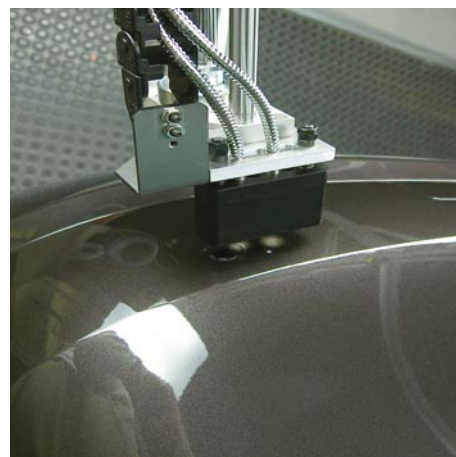
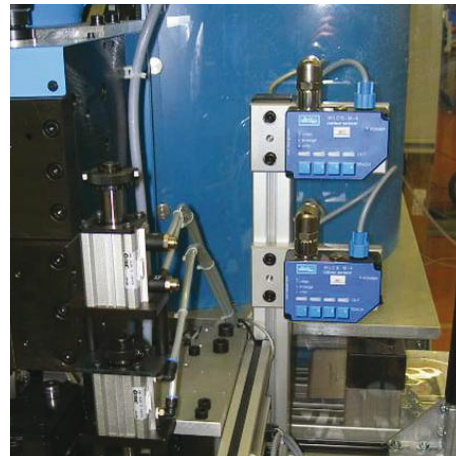

Basics and selection criteria

Page

4 - 5

Universal color sensors

<i>Model</i>	<i>Button teach</i>	<i>Software teach</i>	<i>Color difference</i>	<i>Page</i>
colorSENSOR LT-1-LC-10	3	-	$\Delta E \geq 1.5$	6 - 7
colorSENSOR LT-1-LC-20	-	31 colors	$\Delta E \geq 1.5$	8 - 9
colorSENSOR LT-1-ST	3	15 colors	$\Delta E \geq 1.5$	10 - 11
colorSENSOR WLCS-M-41	4	-	$\Delta E \geq 1.5$	12 - 13
colorSENSOR LT-2-ST	-	255 colors	$\Delta E \geq 0.8$	14 - 15
colorSENSOR LT-2-DU	8	255 colors	$\Delta E \geq 0.8$	16 - 17
colorSENSOR LT-3-HE	31	31 colors	$\Delta E \geq 0.5$	18 - 19
colorSENSOR LT-3-LU	31	31 colors	$\Delta E \geq 0.5$	20 - 21

Color sensors for special measurement targets

<i>Model</i>	<i>Description</i>	<i>Color difference</i>	<i>Page</i>
colorSENSOR OT-3-MA	Color control from a great distance for matt surfaces	$\Delta E \geq 0.5$	22 - 23
colorSENSOR OT-3-GL	Color control on non-homogeneous and shiny surfaces	$\Delta E \geq 0.5$	24 - 25
colorSENSOR OT-3-HR	Color control on reflective and textured surfaces	$\Delta E \geq 0.5$	26 - 27
colorSENSOR OT-3-LD	Color control at a very large distance	$\Delta E \geq 1.5$	28 - 29
colorSENSOR OT-3-LU	Color control of fluorescent objects	$\Delta E \geq 0.5$	30 - 31

Quality inspection of LEDs and illumination

<i>Model</i>	<i>Description</i>	<i>Measuring points</i>	<i>Page</i>
colorSENSOR LT-2-ST	LED tests of function, color and intensity	1	14 - 15
colorSENSOR LT-2-DU	LED tests of function, color and intensity	2	16 - 17
colorSENSOR LT-3-HE	LED tests of function, color and intensity with high accuracy	1	18 - 19
colorSENSOR OT-3-MA	LED lamp and illumination test of function, color and intensity	1	22 - 23
colorSENSOR OT-3-LD	LED lamp and illumination test of function, color and intensity from a great distance	1	28 - 29
colorCONTROL MFA	LED tests of function, color and intensity	5/10/15/20/55/100	32 - 33

Accessories

	<i>Page</i>
Optical fibers	34 - 41
Cable	42
Pin assignment of cables (power supply)	43

BASICS AND SELECTION CRITERIA

Standard color space CIE 1931 (xy color space)

This color space corresponds to the human color perception (very large green and small blues/red sector).

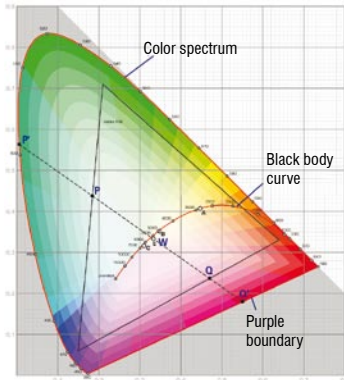

CIE – Commission internationale de l'éclairage
 CIE standardized theoretical primary colors
 $x = \text{red}; y = \text{green}; z = \text{blue} (x+y+z = 1)$
 Color spectrum = „pure“ colors
 $W = \text{whitepoint} (x=y=z=1/3)$
 Black body curve = color as the temperature of an ideal black radiator
 Suitable for green and active light (LED) test

Standard color space CIE Lab

Ideal color space for color test, as each color range is the same size.

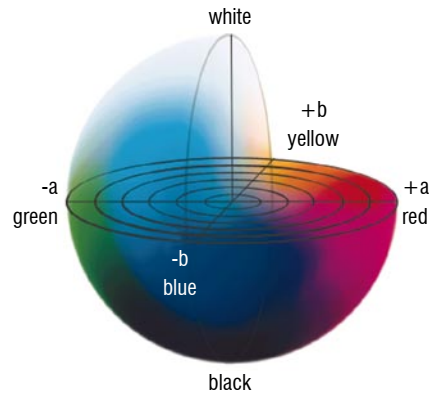

Each color is defined by the color location ($L^*; a^*; b^*$)
 L^* = Luminosity value (black = 0; white = 100)
 a^* = Green / red value (green = -100; red = +100)
 b^* = Blue / yellow value (blue = -100; yellow = +100)

HSV / HSI color space

Ideal color space for LED inspection.
 Is used primarily with the colorCONTROL MFA series.

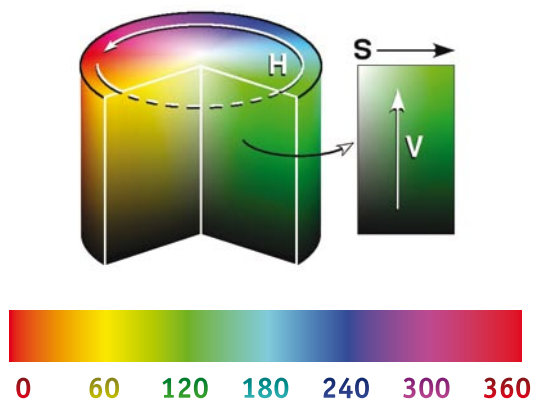

Each color is defined by the color location (H; S; V)
 $H = \text{Hue} (\text{red} = 0^\circ; \text{green} = 120^\circ; \text{blue} = 240^\circ)$
 $S = \text{Saturation}$
 (neutral grey = 0%; „pure“ color = 100 %)
 $V = \text{Value of luminosity}$
 $I = \text{Intensity (light intensity)}$
 (dark = 0%; totally light = 100%)

What is meant by Delta E?

Delta E; ΔE ; $dE =$ Is a measure of the perceived color difference between two colors (DIN 5033)

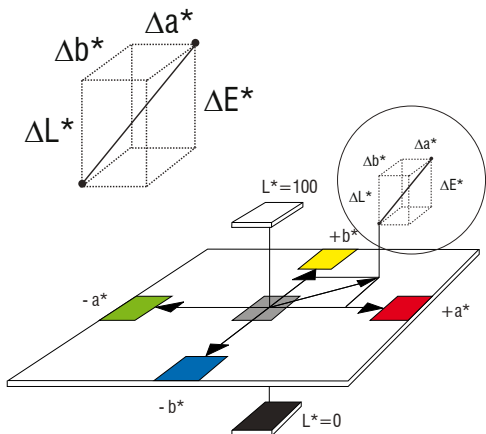

$$\Delta E = \sqrt{(L_p^* - L_v^*)^2 + (a_p^* - a_v^*)^2 + (b_p^* - b_v^*)^2} = 5$$

A ΔE of 5 corresponds roughly to the difference grey 50% and grey 55%

Selection criteria for choosing colorSENSOR type

Tasks / colorSENSOR		LT-1-LC-10	LT-1-LC-20	LT-1-ST	WLCS-M-41	LT-2-ST	LT-2-DU	LT-3-HE	LT-3-LU
Number of color memories		3	31	15 (255)	4	255	255 (2x15)	31	31
Color difference		$\Delta E \geq 1.5$	$\Delta E \geq 1.5$	$\Delta E \geq 1.5$	$\Delta E \geq 1.5$	$\Delta E \geq 0.8$	$\Delta E \geq 0.8$	$\Delta E \geq 0.5$	$\Delta E \geq 0.5$
Detection distance		2-100mm	2-100mm	2-100mm	2-150mm	2-200mm	2-200mm	2-200mm	2-200mm
Light spot Ø		0.6-20mm	0.6-20mm	0.6-20mm	0.6-30mm	0.6-30mm	0.6-30mm	0.6-30mm	0.6-30mm
Optical fiber + lens		x	x	x	x	x	x	x	x
Teach-in		x		x	x		x	x	x
Button teach		3		3	4		8 (2x4)	31	31
Software			x	x		x	x	x	x
Software teach			31	15 (255)		255	255	31	31
RS 232 interface				x	x	x	x	x	x
USB interface						x	x		
Characteristics of the application	Matt surface	x	x	x	x	x	x	x	x
	Shiny surface	1)	1)	1)	1)	1)	1)	1)	
	Reflective surface								
	Textured surface								
	High temperature to 400 °C	x	x	x	x	x	x	x	
	Fluorescent surfaces								x
	Large working distance								
LED test						x	x	x	
Page		4-5	6-7	8-9	10-11	12-13	14-15	16-17	18-19

1) with reservations in connection with KL-D-XX focus lens

Tech. specifications / colorSENSOR		OT-3-MA	OT-3-GL	OT-3-HR	OT-3-LD	OT-3-LU			
Number of color memories		31	31	31	31	31			
Color difference ΔE		≥ 0.5	≥ 0.5	≥ 0.5	≥ 1.5	≥ 0.5			
Detection distance		10-400mm	10-300mm	10-300mm	200-800mm	10-100mm			
Light spot Ø		4-50mm	4-50mm	4-50mm	20-80mm	8-40mm			
Optical fiber + lens									
Teach-in		x	x	x	x	x			
Button teach (Colors)		31	31	31	31	31			
Software		x	x	x	x	x			
Software teach (Colors)		31	31	31	31	31			
RS 232 interface		x	x	x	x	x			
USB interface									
Characteristics of the application	Matt surface	x	x	x	x				
	Shiny surface		x	x					
	Reflective surface			x					
	Textured surface		x	x					
	High temperature to 400 °C								
	Fluorescent surfaces						x		
	Large working distance					x			
LED test									
Page		20-21	22-23	24-25	26-27	28-29			

colorSENSOR LT-1-LC-10

Compact color sensor



- ▶ 3 colors via Teach-in
- ▶ 5-fold tolerance adjustment
- ▶ Optical fiber with focus lenses

Features:

- Color memory: 3 (via Teach-in)
- White light LED
- $L^*a^*b^*$ transformation
- True Color color chip
- Several TEACH possibilities (via PC or external)
- Adaption of optical fiber and focus lens
- Robust aluminium housing
- Switching frequency up to 1kHz

Application examples:

- Detection of color rings on metallic and plastic sleeves
- Reading out and statistically evaluating color values
- Recognizing color markings in the printing industry
- Color and grey-scale detection
- Inspection of packaging
- Sorting tasks on the basis of color (e.g. checking O-rings, closures, crown corks, and labels)
- Color recognition on interior components (e.g. head supports, ...)
- LED tests of function, color and intensity

With the aid of a modulated white light LED, a spot of white light is projected directly through an optical fiber to the surface being inspected. Part of the light back-scattered from the object being measured is now focused by optical fiber onto a perceptive True-Color detector element, sub-divided according to RGB color values and transformed into $L^*a^*b^*$.

With the LC-10, up to 3 colors can be taught easily via the Teach-in or external teach functions. If a color that has been taught is recognized by the sensor, a change in switching condition is made via the 3 encoded digital outputs.

Type	LT-1-LC-10
Article number	10234059
Object distance	Dependent on the optical fibers used and the optical heads reflex mode fiber optical cables typically 2mm-15mm with lens, typically 5mm-100mm ¹⁾
Light spot diameter	Dependent on the optical fibers used and the optical heads \varnothing 0,6mm-20mm ¹⁾
Color difference	$\Delta E \geq 1.5$
Color spaces	L*a*b*
Averaging	-
Size of the color memory	max. 4 colors in non-volatile EEPROM with tolerance level
Switching frequency	max. 1kHz
Reproducibility	3x12-Bit-A/D conversion
Temperature drift X,Y	0.2% /K
Light source	White light LED, AC mode
Type of illumination	via optical fiber
Effect through illumination	suitable for flexibility
Ambient light	Up to 5000 Lux
Intermittent light operation	AC: typ. 10kHz
Power supply	+18 - 28VDC
Current consumption	typ. 100mA
Max. switching current	100mA
TEACH button/inputs	4 buttons, Set and IN0 - IN2 for external teaching of the color reference and tolerance level
Outputs	OUT 0 - OUT 2, digital (0V/+Ub), 100mA max. switching current
Switching state display	Visualisation by means of 3 yellow LEDs
Interface	-
Type of connector	to PLC: 8-pole flange socket (Binder series 712)
Connection cable	to Power/PLC: Art. No. 11234091
Receiver	3-color filter detector (TRUE COLOR detector, color filter curve as per CIE 1931)
Software	-
Pulse extension	10ms
Signal amplification	-
Housing material	Aluminium, black anodised
Operating temperature	-10°C - +55°C
Storage temperature	-10°C - +85°C
Protection class	IP54
Optical fiber	Page 34 onwards

¹⁾ Type: FAR-T-A2.0-2,5-1200-67° reflex type
Type: FAD-T-A2.0-2,5-1200-67° transmitted light (p.34 onwards)

Dimensions:

Dimensions in mm, not to scale

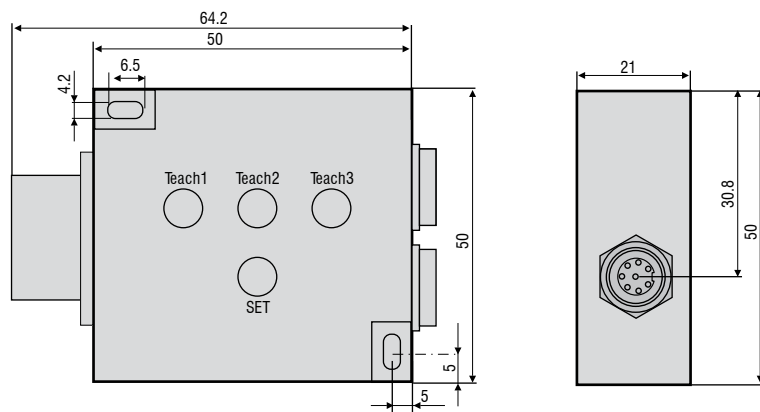

colorSENSOR LT-1-LC-20

Compact color sensor



- ▶ 31 Colors via software
- ▶ 5-fold tolerance adjustment
- ▶ Optical fiber with focus lenses

Features:

- Color memory: 31 (via software)
- RS232 interface
- White light LED
- Color spaces: X/Y INT; s/i M (Lab)
- True Color color chip
- Several TEACH possibilities (via PC or external)
- A variety of evaluation algorithms can be activated
- Color grouping
- Adaption of optical fiber and focus lens
- Robust aluminium housing
- Switching frequency up to 35kHz
- colorCONTROL S software

Application examples:

- Detection of color rings on metallic and plastic sleeves
- Reading out and statistically evaluating color values
- Recognizing color markings in the printing industry
- Color and grey-scale detection
- Inspection of packaging
- Sorting tasks on the basis of color (e.g. checking O-rings, closures, crown corks, and labels)
- Color recognition on interior components (e.g. head supports, ...)
- LED tests of function, color and intensity

With the aid of a modulated white light LED, a spot of white light is projected directly through an optical fiber to the surface being inspected. Part of the light back-scattered from the object being measured is now focused by optical fiber onto a perceptive True-Color detector element, sub-divided according to RGB color values and transformed into $L^*a^*b^*$.

With the LC-20, 31 colors can be taught using the colorCONTROL S software. If a color that has been taught is recognized by the sensor, a change in switching condition is made via the 5 encoded digital outputs.

Type	LT-1-LC-20
Article number	10234060
Object distance	Dependent on the optical fibers used and the optical heads Reflex mode fiber optical cables typically 2mm-15mm with lens, typically 5mm-100mm ¹⁾
Light spot diameter	Dependent on the optical fibers used and the optical heads Reflex mode fiber optical cables, typically Ø 0.6mm-20mm ¹⁾
Color difference	$\Delta E \geq 1.5$
Color spaces	X/Y INT; s/i M (Lab)
Averaging	More than max. 32768 values
Size of the color memory	Max. 31 colors in non-volatile EEPROM with parameter sets
Switching frequency	Max. 35kHz (depending on number of colors being taught and the setting for the averaging)
Reproducibility	In the x,y color range, 1 digit each with 12-Bit-A/D conversion
Temperature drift X,Y	< 0.01% K
Light source	Super-bright white light LED, AC or DC or PULSE mode (adjustable or OFF for self-luminous objects, software-switchable)
Type of illumination	Via optical fiber
Effect through illumination	Suitable for flexibility
Ambient light	Up to 5000Lux (in AC and PULSE mode)
Intermittent light operation	AC: typ. to 20kHz (depending on amplification level AMP1 to AMP8) DC: typ. to 35kHz PULSE mode: typ. to 5kHz
Power supply	+24VDC ($\pm 10\%$), inverse polarity protected, overload-proof
Current consumption	< 160mA
Max. switching current	100mA, short-circuit protected
TEACH button/inputs	No button for external teaching of the color references apart from IN0
Outputs	OUT 0 - OUT 4, digital (0V/+Ub), short-circuit protected, 100 mA max. switching current npn-, pnp-capable (bright or dark switching, switchable)
Switching state display	-
Interface	RS232
Type of connector	to PLC: 8-pole flange socket (Binder series 712) to PC: 8-pole flange socket (Binder series 712)
Connection cable	to power/PLC: Art. No. 11234091 / to PC: 11234095 (RS232); 11234096 (USB)
Receiver	3-color filter detector (TRUE COLOR detector, color filter curve as per CIE 1931)
Software	colorCONTROL S
Pulse extension	Adjustable 0ms-100ms
Signal amplification	8 stage (AMP1 - AMP8), adjustable
Housing material	Aluminium, black anodised
Operating temperature	-20°C - +55°C
Storage temperature	-20°C - +85°C
Protection class	IP54
EMC test according	DIN EN 60947-5-2
Optical fiber	Page 34 onwards

¹⁾ Typ: FAR-T-A2.0-2,5-1200-67° Reflex

Typ: FAD-T-A2.0-2,5-1200-67° Transmitted light (p. 34 onwards)

Dimensions:

Dimensions in mm, not to scale

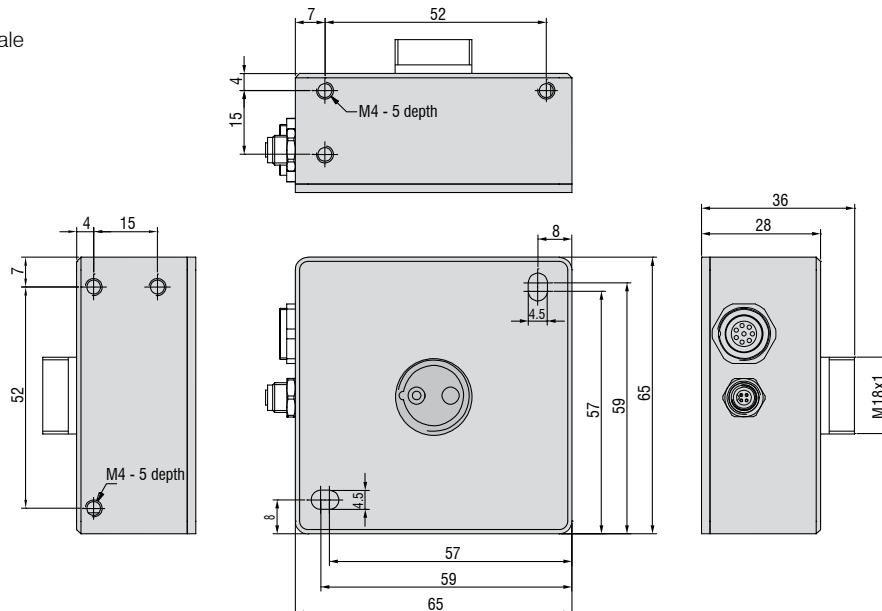

colorSENSOR LT-1-ST

Compact True Color color recognition sensor



- ▶ 255 Colors can be saved
- ▶ Teach-in (3 colors)
- ▶ PC programmable via RS232
- ▶ Optical fiber with focus lenses
- ▶ Adjustable illumination

Features:

- Color memory:
3 (Teach-In buttons), 255 (software)
max. 4 color channels (15 with binary coding)
- RS232 interface
- White light LED
- $L^*a^*b^*$ / $L^*u^*v^*$ transformation
- Switchable for LED recognition
- A variety of evaluation algorithms can be activated
- 15 color grouping are possible
- Adaption of optical fiber and focus lens
- Robust aluminium housing
- Switching frequency to 10kHz
- colorCONTROL LT software
- Recording of color values by means of Color
Watcher software

Application examples:

- Detection of color rings on metallic and plastic sleeves
- Reading out and statistically evaluating color values
- Recognizing color markings in the printing industry
- Color and grey-scale detection
- Inspection of packaging
- Sorting tasks on the basis of color
(e.g. checking O-rings, closures, crown corks, and labels)
- Color recognition on interior components
(e.g. head supports, ...)
- LED tests of function, color and intensity

Typ	LT-1-ST
Article number	10234061
Object distance	Dependent on the optical fibers used and the optical heads reflex mode fiber optical cables typically 2mm-25mm with lens, typically 5mm-100mm ¹⁾
Light spot diameter	Dependent on the optical fibers used and the optical heads reflex mode fiber optical cables, typically 0.6mm-20mm ¹⁾
Color difference	$\Delta E \geq 1.5$
Color spaces	XYZ, xyY, $L_{99}a_{99}b_{99}$, $L^*a^*b^*$, $L^*u^*v^*$, u'vL*
Averaging	More than max. 57600 values
Size of the color memory	max. 255 colors in non-volatile EEPROM with parameter sets
Switching frequency	max. 10kHz (depending on number of colors being taught and the setting for the averaging)
Reproducibility	3x12-Bit-A/D conversion
Temperature drift X,Y	0.2%/K
Light source	White light LED, AC mode (adjustable or OFF for self-luminous objects, software-switchable)
Type of illumination	via optical fibers
Effect through illumination	suitable for flexibility
Ambient light	up to 5000 Lux
Intermittent light operation	AC: typ. to 10kHz
Power supply	+18 - 28VDC
Current consumption	typ. 100mA
Max. switching current	100mA
TEACH button/inputs	4 buttons, Set and IN0 - IN2 for external teaching of the color reference and tolerance level
Outputs	OUT 0 - OUT 2, digital (0V/+Ub), 100mA max. switching current
Switching state display	Visualisation by means of 3 yellow LEDs
Interface	RS232
Type of connector	to PLC: 8-pole flange socket (Binder series 712) to PC: 4-pole flange socket (Binder series 712)
Connection cable	to power/PLC: Art. No. 11234091 / to PC: art.no. 11234093 (RS232); 11234094 (USB)
Receiver	3-color filter detector (TRUE COLOR detector, color filter curve as per CIE 1931)
Software	colorCONTROL LT
Pulse extension	adjustable 0ms-100ms
Signal amplification	-
Housing material	Aluminium, black anodised
Operating temperature	-10°C - +55°C
Storage temperature	-10°C - +85°C
Protection class	IP54
Optical fiber	page 34 onwards

¹⁾ Type: FAR-T-A2.0-2,5-1200-67° reflex

Type: FAD-T-A2.0-2,5-1200-67° transmitted light (p.34 onwards)

Dimensions:

Dimensions in mm, not to scale

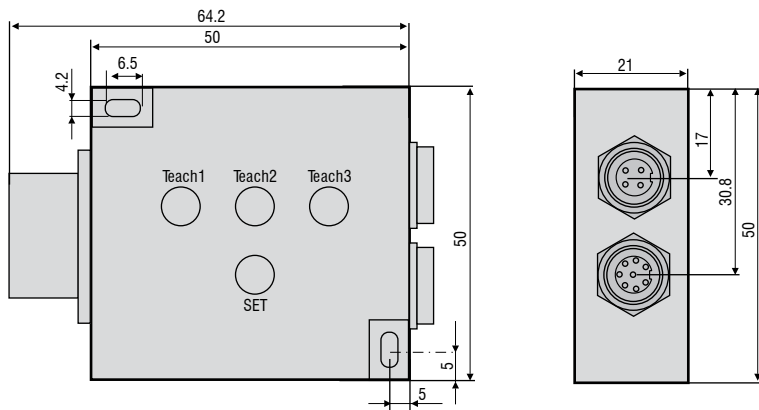

colorSENSOR WLCS-M-41

The all-round talent for color recognition



- ▶ 4 color memory „Teach-in“
- ▶ Optical fiber with focus lenses to 100mm
- ▶ Color and intensity evaluation
- ▶ High color resolution
- ▶ „Plug & Play“ operating concept

Features:

- Multi-Teach by buttons on the sensor
- Separation of sensor and sampling point (explosion-protected for hazardous areas)
- Switch Output, 4x potential-free
- Adaption of optical fibers for every application
- Working distance 2-100mm, depending on optical fiber and lens
- Protection class IP65
- Solid enclosure concept for rugged industrial applications
- Independent of distance due to color and intensity evaluation (C and C+ I)
- Resolution
 - Color \leq 12bit
 - Intensity \leq 12bit
- External teaching
- Perceptive color processing
- White light LED as light source
- RS232 interface
- 4 color grouping can be saved
- Four-stage signal amplification
- Color spaces: C, C+I

Advantages:

- Application-oriented teaching of tolerances through „multiple teaching“ per channel
- Separate tolerance setting via potentiometer for each color memory is also possible
- Genuine three sector device
- Optical fiber adaption
- Universal operation
- No selectivity gaps in the color range

Application examples:

- Color sorting and inspection
- Recognizing similar colors
- Recording color codes
- Recognizing positions
- Recognizing locking compounds
- All color recognition tasks (between 390 and 750nm)
- Recognition of intensity

Type	WLCS-M-41
Article number	10234062
Object distance	Dependent on the optical fibers used and the optical heads Reflex mode fiber optical cables typically 2mm-25mm with lens, typically 5mm-100mm ¹⁾
Light spot diameter	Dependent on the optical fibers used and the optical heads Reflex mode fiber optical cables, typically Ø 0.6mm-30mm ¹⁾
Color difference	$\Delta E \geq 1.5$
Color spaces	C, C+I
Averaging	more than 32 values
Size of the color memory	max. 4 colors in non-volatile EEPROM with tolerance level via potentiometer
Switching frequency	1kHz, 32Hz with averaging
Reproducibility	in the C+I color range ≤ 12 Bit-A/D conversion
Temperature drift X,Y	0.1% / K
Light source	White light LED, AC mode
Type of illumination	via optical fiber
Effect through illumination	suitable for flexibility
Ambient light	up to 5000Lux
Intermittent light operation	AC: typ. 20kHz
Power supply	+18 - 30VDC
Current consumption	typ. 240mA
Max. switching current	240mA
TEACH button/inputs	4 buttons and IN1 - IN4 for external teaching of the color reference
Outputs	OUT 1-OUT 4, digital (0V/+Ub), short-circuit protected, 100mA max. switching current
Switching state display	Visualisation by means of 4 yellow LEDs
Interface	RS232
Type of connector	to PLC: 19-pole flange socket (Harting) to PC: 3-pole flange socket
Connection cable	to power/PLC: art no. 11234089 / to PC: art.no. 11234090 (RS232)
Receiver	3-PIN photodiodes with color filter
Software	-
Pulse extension	-
Signal amplification	-
Housing material	Aluminium, black anodised
Operating temperature	0°C - +50°C
Storage temperature	0°C - +80°C
Protection class	IP65
Optical fiber	p. 34 onwards

¹⁾ Type: FAR-T-A2.0-2,5-1200-67° reflex

Type: FAD-T-A2.0-2,5-1200-67° transmitted light (p. 34 onwards)

Dimensions:

Dimensions in mm, not to scale

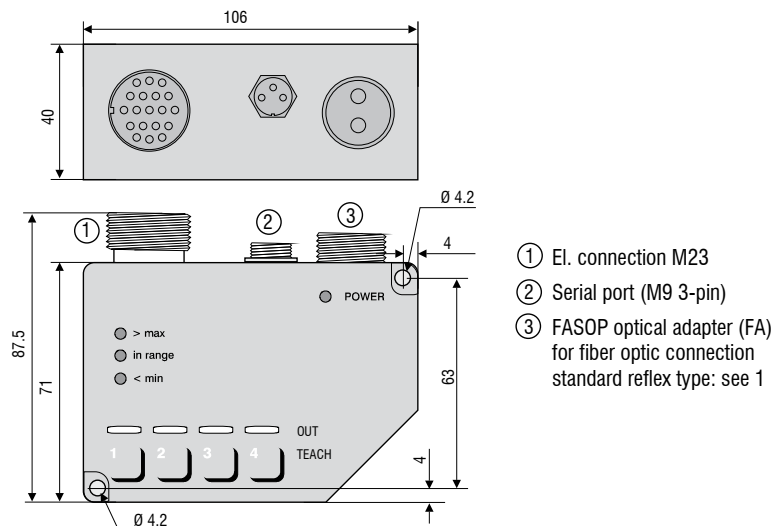

colorSENSOR LT-2-ST

Standard color sensor



- ▶ 255 colors can be saved
- ▶ Perceptive color sensor system
- ▶ PC programmable via RS232 / USB
- ▶ Optical fiber with focus lenses
- ▶ Distinguishing colors like the human eye

Features:

- Color memory: up to 255 colors
- RS232/ USB interface
- White light LED
- $L^*a^*b^*$ / $L^*u^*v^*$ / DIN99 transformation
- can be re-calibrated
- Switchable for LED recognition
- Several TEACH possibilities (via PC or external)
- A variety of evaluation algorithms can be activated
- Color grouping
- Adaption of FASOP optical fiber and focus lenses
- Robust aluminium housing
- Switching frequency up to 15kHz
- colorCONTROL LT software

Application examples:

- Quality assurance
- Reading out and statistically evaluating color values
- Recognizing color markings in the printing industry
- Color and grey-scale detection
- Recognizing the degree of browning with bakery products
- Inspection of packaging
- Sorting tasks on the basis of color (e.g. checking O-rings, closures, crown corks, and labels)
- Color recognition on vehicle body parts, bumpers, doors, etc.
- LED tests of function, color and intensity

Type	LT-2-ST
Article number	10234063
Object distance	Dependent on the optical fibers used and the optical heads Reflex optics fiber typ. 2mm-25mm with lens, typ. 5mm-200mm ¹⁾
Light spot diameter	Dependent on the optical fibers used and the optical heads Reflex optical fiber typ. Ø 0.6mm-30mm ¹⁾
Color difference	$\Delta E \geq 0.8$
Color spaces	XYZ, xyY, $L_{99}a_{99}b_{99}$, $L^*a^*b^*$, $L^*u^*v^*$, u ^v L*
Averaging	more than max. 57600 values
Size of the color memory	max. 255 colors in non-volatile EEPROM with parameter sets
Switching frequency	max. 15kHz (depending on number of colors being taught and the setting for the averaging)
Reproducibility	3x12-Bit-A/D conversion
Temperature drift X,Y	0.2% /K
Light source	2x White light LED, AC mode (adjustable or OFF for self-luminous objects, software-switchable) ²⁾
Type of illumination	via optical fiber
Effect through illumination	suitable for flexibility
Ambient light	to 5000Lux
Intermittent light operation	AC: typically to 15kHz (depending on 4 amplification levels)
Power supply	+18 - 28VDC
Current consumption	typ. 500mA
Max. switching current	100mA
TEACH button/inputs	No button for external teaching of the color references apart from IN0 - IN1
Outputs	OUT 0 - OUT 7, digital (0V/+Ub), 100 mA Max. switching current
Switching state display	-
Interface	RS232, USB 2.0
Type of connector	to PLC: 8-pole flange socket (Binder series 712) to PC: 4-pole flange socket (Binder series 712)
Connection cable	to power/PLC: 2 x art. no. 11234091 / to PC: art. no. 11234093 (RS232); 11234094 (USB)
Receiver	3-color filter detector (TRUE COLOR detector, color filter curve as per CIE 1931)
Software	colorCONTROL LT
Pulse extension	adjustable 0ms-100ms
Signal amplification	4 levels (1, 5, 25, and 100)
Housing material	Aluminium, black anodised
Operating temperature	-10 °C - +55°C
Storage temperature	-10 °C - +85°C
Protection class	IP65
Optical fiber	p. 34 onwards

¹⁾ Type: FAR-T-A2.0-2,5-1200-67° Reflex

Type: FAD-T-A2.0-2,5-1200-67° Transmitted light (p. 34 onwards)

²⁾ suitable for LED testing

Dimensions:

Dimensions in mm, not to scale

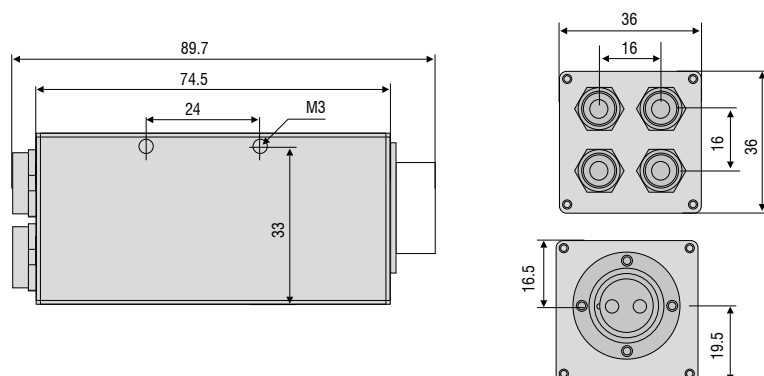

colorSENSOR LT-2-DU

2-channel color sensor



- ▶ 2-channel color sensor
- ▶ 255 colors can be saved
- ▶ Teach-in (8 colors)
- ▶ PC programmable via RS232 / USB
- ▶ Optical fiber with focus lenses
- ▶ Distinguishing colors like the human eye

Features:

- Color memory: 8 (Teach-in) 255 (software)
- 2x White light LED
- RS232 and USB 2.0 interface
- Color spaces: XYZ, xyY, $L_{99}a_{99}b_{99}$, $L^*a^*b^*$, $L^*u^*v^*$, $u'v'L^*$
- Switchable for LED recognition
- Several TEACH possibilities (via PC or external))
- Difference / reference / 2-channel mode
- Adaption of FASOP optical fiber and focus lens
- Logical link, deviation mode
- Switching frequency to 15kHz
- Perceptive color processing
- Six teach buttons on the housing
- 4 stage signal amplification
- colorCONTROL LT software

Application examples:

- Quality assurance
- Reading out and statistically evaluating color values
- Detection of color rings on metallic and plastic sleeves
- Recognizing color markings in the printing industry
- Color and grey-scale detection
- Checking color gradients
- Checking color transitions
- Checking color deviations
- Inspection of packaging
- Color recognition on vehicle body parts, bumpers, doors, etc.
- LED tests of function, color and intensity

Type	LT-2-DU
Article number	10234064
Object distance	Dependent on the optical fibers used and the optical heads Reflex mode fiber optical cables typically 2mm-25mm with lens, typically 5mm-200 mm ¹⁾
Light spot diameter	Dependent on the optical fibers used and the optical heads Reflex optical fiber typ. Ø 0.6mm-30mm ¹⁾
Color difference	$\Delta E \geq 0.8$
Color spaces	XYZ, xyY, $L_{99}a_{99}b_{99}$, $L^*a^*b^*$, $L^*u^*v^*$, u ^v L*
Averaging	more than max. 57600 values
Size of the color memory	max. 255 colors in non-volatile EEPROM with parameter sets
Switching frequency	max. 15kHz (depending on number of colors being taught and the setting for the averaging)
Reproducibility	3x12-Bit-A/D conversion
Temperature drift X,Y	0.2% /K
Light source	2x White light LED, 2x White light LED, AC mode (adjustable or OFF for self-luminous objects, software-switchable) ²⁾
Type of illumination	via optical fiber
Effect through illumination	suitable in flexibility
Ambient light	to 5000Lux
Intermittent light operation	AC: typically to 15kHz (depending on 4 amplification levels)
Power supply	+18 - 28VDC
Current consumption	typ. 500mA
Max. switching current	100mA
TEACH button/inputs	6 buttons, ToI, Lo/Hi and IN0/4 - IN3/8 for external teaching of the color reference and tolerance level
Outputs	OUT 0 - OUT 7, digital (0V/+Ub), 100mA max. switching current
Switching state display	Visualisation by means of 3 yellow LEDs
Interface	RS232, USB 2.0
Type of connector	to PLC: 8-pole flange socket (Binder series 712) to PC: 4-pole flange socket (Binder series 712)
Connection cable	to power/PLC: 2 x art no. 11234091 / to PC: art no. 11234093 (RS232); 11234094 (USB)
Receiver	2x3-color filter detector (TRUE COLOR detector, color filter curve as per CIE 1931)
Software	colorCONTROL LT
Pulse extension	adjustable 0ms-100ms
Signal amplification	4 levels (1, 5, 25 and 100)
Housing material	Aluminium, black anodised
Operating temperature	-10 °C - +55°C
Storage temperature	-10 °C - +85°C
Protection class	IP54
Optical fiber	p. 34 onwards

¹⁾ Type: FAR-T-A2.0-2,5-1200-67° Reflex

Type: FAD-T-A2.0-2,5-1200-67° Transmitted light (p. 34 onwards)

²⁾ suitable for LED testing

Dimensions:

Dimensions in mm, not to scale

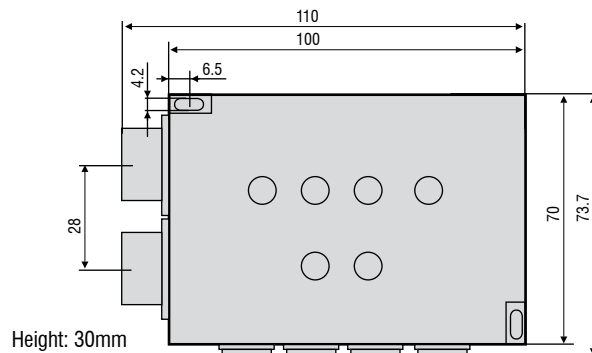

colorSENSOR LT-3-HE

High-end color sensor

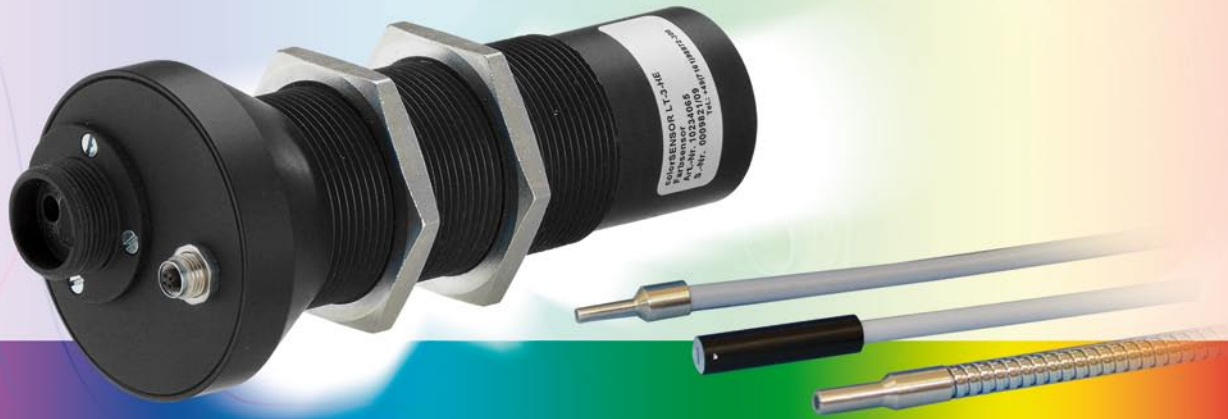

- ▶ 31 colors can be saved
- ▶ Optical fiber adaption
- ▶ Color and grey scale evaluation
- ▶ PC programmable via RS232 / USB

Features:

- Color memory: 31 Colors per Teach-in and software
- RS232 interface (USB adapter optional)
- Modulated white light LED (can be connected for external super-bright white light source)
- Switchable brightness readjustment
- Color and grey-scale detection
- Switchable averaging
- A variety of evaluation algorithms can be activated
- Switching frequency max. 30kHz
- Switching state display
- Temperature compensation $<0.01\%/K$
- Eight-stage signal amplification, adjustable
- Color spaces: X/Y INT; s/i M (Lab)

Application examples:

- Detection of color rings
- Recognizing color markings in the printing industry
- Inspection of packaging
- Sorting tasks on the basis of color
- Color recognition on interior components
- Color control of self-luminous objects (LEDs, displays, etc.)

Type	LT-3-HE
Article number	10234065
Object distance	Dependent on the optical fibers used and the optical heads Reflex optical fiber typ. 2mm-25mm with lens typ. 5mm-200mm ¹⁾
Light spot diameter	Dependent on the optical fibers used and the optical heads Reflex optical fiber typ. Ø 0.6mm-30mm ¹⁾
Color difference	$\Delta E \geq 0.5$
Color spaces	X/Y INT; s/i M (Lab)
Averaging	more than max. 32768 values
Size of the color memory	max. 31 colors in non-volatile EEPROM with parameter sets
Switching frequency	max. 30kHz (depending on number of colors being taught and the setting for the averaging)
Reproducibility	In the x,y color range, 1 digit each with 12-Bit-A/D conversion
Temperature drift X,Y	< 0.01% /K
Light source	Super-bright white light LED, AC or DC, (adjustable or OFF for self-luminous objects, software-switchable) ²⁾
Type of illumination	via optical fiber
Effect through illumination	suitable for flexibility
Ambient light	to 5000Lux (AC-mode)
Intermittent light operation	AC: typ. 10kHz to 40kHz (depending on amplification level AMP1 to AMP8) DC: switchable by PC software
Power supply	+24VDC ($\pm 10\%$), inverse polarity protected, overload-proof
Current consumption	typ. 320mA
Max. switching current	100mA, short-circuit protected
TEACH button/inputs	1 button and IN0 for external teaching of the color references
Outputs	OUT 0 - OUT 4, digital (0V/+Ub), short-circuit protected, 100mA max. switching current npn-, pnp-capable (bright or dark switching, switchable)
Switching state display	Visualisation by means of 5 yellow LEDs
Interface	RS232 (optional USB)
Type of connector	to PLC: 8-pole flange socket (Binder series 712) to PC: 4-pole flange socket (Binder series 707)
Connection cable	to power/PLC: art. no. 11234091 / to PC: art. no 11234095 (RS232); 11234096 (USB).
Receiver	3-color filter detector (TRUE COLOR detector, color filter curve as per CIE 1931)
Software	colorCONTROL S
Pulse extension	adjustable 0ms-100ms
Signal amplification	8 stage (AMP1 - AMP8), adjustable
Housing material	Aluminium, black anodised
Operating temperature	-20°C - +55°C
Storage temperature	-20°C - +85°C
Protection class	IP67 (lens), IP64 (electronics)
EMC test according	DIN EN 60947-5-2
Optical fiber	p. 34 onwards

¹⁾ Type: FAR-T-A2.0-2.5-1200-67° Reflex
Type: FAD-T-A2.0-2.5-1200-67° Transmitted light (p. 34 onwards)

²⁾ suitable for LED testing

Dimensions:

Dimensions in mm, not to scale

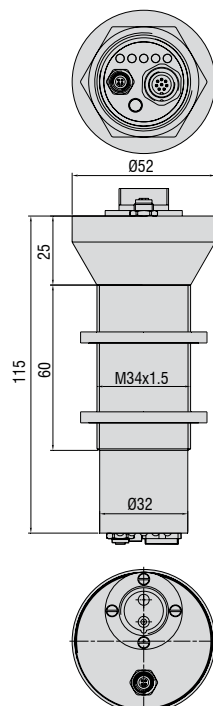

colorSENSOR LT-3-LU

High-end color sensor for fluorescent objects

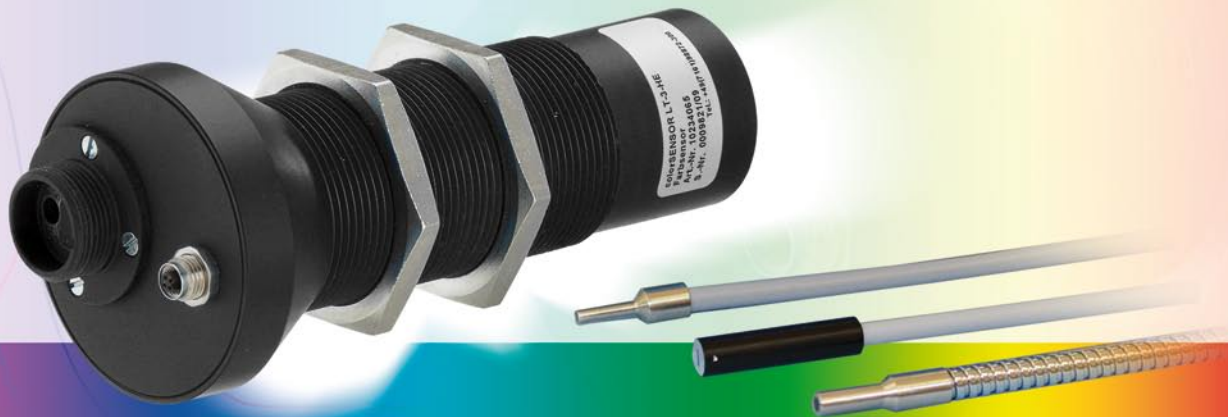

- ▶ 31 colors can be saved
- ▶ Adaption of UV-light capable optical fibers
- ▶ Color and grey scale evaluation of luminescent colors
- ▶ PC programmable via RS232 / USB

Features:

- Color memory: 31 colors per Teach-in and software
- RS232 interface (USB adapter optional)
- Modulated white light LED (385nm)
(can be connected for external super-bright white light source)
- Switchable brightness readjustment
- Color and grey-scale detection
- Switchable averaging
- A variety of evaluation algorithms can be activated
- Switching frequency max. 30kHz
- Switching state display
- UV optical fiber available
- colorCONTROL S software

Application examples:

- Detection of luminescent colors
- Recognizing color markings in the printing industry
- Inspection of packaging
- Sorting tasks on the basis of color

Type	LT-3-LU
Article number	10234066
Object distance	Dependent on the optical fibers used and the optical heads Reflex optical fiber typ. 2mm-25mm with lens typ. 5mm-50mm ¹⁾
Light spot diameter	Dependent on the optical fibers used and the optical heads ¹⁾
Color difference	$\Delta E \geq 0.5$
Color spaces	X/Y INT; s/i M (Lab)
Averaging	more than max. 32768 values
Size of the color memory	max. 31 colors in non-volatile EEPROM with parameter sets
Switching frequency	max. 30kHz (depending on number of colors being taught and the setting for the averaging)
Reproducibility	In the x,y color range, 1 digit each with 12-Bit-A/D conversion
Temperature drift X,Y	< 0.01% /K
Light source	Super-bright UV LED, 385nm, AC-, DC mode, (adjustable or OFF for self-luminous objects, software-switchable)
Type of illumination	via optical fiber
Effect through illumination	Suitable for flexibly recognizing luminescent colors
Ambient light	to 5000 Lux (AC mode)
Intermittent light operation	AC: typ. 10kHz to 40kHz (depending on amplification level AMP1 to AMP8) DC: switchable by PC software
Power supply	+24VDC ($\pm 10\%$), inverse polarity protected, overload-proof
Current consumption	typ. 320mA
Max. switching current	100mA, short-circuit protected
TEACH button/inputs	1 button and IN0 for external teaching of the color references
Outputs	OUT 0 - OUT 4, digital (0V/+Ub), short-circuit protected, 100mA max. switching current npn-, pnp-capable (bright or dark switching, switchable)
Switching state display	Visualisation by means of 5 yellow LEDs
Interface	RS232 (optional USB)
Type of connector	to PLC: 8-pole flange socket (Binder series 712) to PC: 4-pole flange socket (Binder series 707)
Connection cable	to power/PLC: art. no. 11234091 / to PC: art. no 11234095 (RS232); 11234096 (USB).
Receiver	3-color filter detector (TRUE COLOR detector, color filter curve as per CIE 1931)
Software	colorCONTROL S
Pulse extension	adjustable 0ms-100ms
Signal amplification	8 stage (AMP1 - AMP8), adjustable
Housing material	Aluminium, black anodised
Operating temperature	-20°C - +55°C
Storage temperature	-20°C - +85°C
Protection class	IP67 (lens), IP64 (electronics)
EMC test according	DIN EN 60947-5-2
Optical fiber	p. 34 onwards

¹⁾ Type: FAR-T-A2.0-2,5-1200-67°-UV Reflex
FAD-T-A2.0-2,5-1200-67°-UV Transmitted light

Dimensions:

Dimensions in mm, not to scale

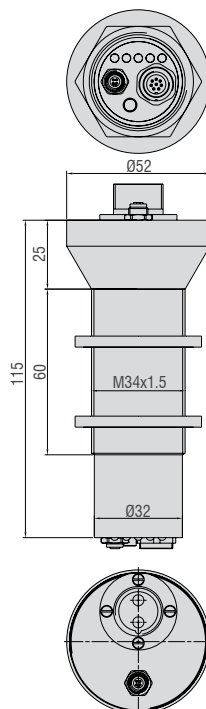

colorSENSOR OT-3-MA

Color sensor for large distances and matt surfaces



- ▶ 31 colors can be saved
- ▶ Focused illumination for rapidly changing object distances
- ▶ Color and grey scale evaluation
- ▶ PC programmable via RS232 / USB

Features:

- White light LED ring, focused, with clear glass covering
- Object distance typ. 10mm - 400mm
- Large dynamic range through focused white light operation
- Color memory: 31 colors per Teach-in and software
- RS232 interface (USB adapter optional)
- Switchable brightness readjustment
- Switching frequency max. 30kHz
- A variety of evaluation algorithms can be activated, e.g. „BEST HIT“ mode
- Switching state display via 5 yellow LEDs
- Switchable averaging
- Color control of self-luminous objects

colorSENSOR OT color sensors are fixed lens sensors with True-Color detection. The sensor automatically illuminates the surface with white light and records the reflected color values. Aside from the optics, the models are almost identical. The illumination can be disabled by software. OT sensors are then suitable for the color detection of self-luminous sources.

Application examples:

- Color recognition of matt surfaces at a distance of up to 400mm
- Detection of color rings
- Recognizing color markings in the printing industry
- Inspection of packaging
- Sorting tasks on the basis of color
- Color control of self-luminous objects (LEDs, displays, etc.)
- Illumination recognition as per color and intensity

Type	OT-3-MA-30-8	OT-3-MA-30-16	OT-3-MA-50-12.5	OT-3-MA-50-25	OT-3-MA-80-36	OT-3-MA-200-20
Article number	10234067	10234068	10234069	10234070	10234071	10234072
Object distance	typ. 10mm-100mm ideal distance 30mm		typ. 20mm-120mm ideal distance 50mm		typ. 40mm-150mm ideal distance 80mm	typ. 50mm-400mm ideal distance 200mm
Light spot	Ø 5-16mm	Ø 10-31mm	Ø 4-24mm	Ø 8-48mm	Ø 30-48mm	Ø 5-40mm
Light spot diameter	Ø 8mm at 30mm	Ø 16mm at 30mm	Ø 12.5mm at 50mm	Ø 25mm at 50mm	Ø 36mm at 80mm	Ø 20mm at 200mm
Color difference	ΔE ≥ 0.5					ΔE ≥ 1.5
Color spaces	X/Y INT; s/i M (Lab)					
Averaging	more than max. 32768 values					
Size of the color memory	max. 31 colors in non-volatile EEPROM with parameter sets					
Switching frequency	max. 30kHz (depending on number of colors being taught and the setting for the averaging)					
Reproducibility	In the x,y color range, 1 digit each with 12-Bit-A/D conversion					
Temperature drift X,Y	< 0.01% /K					
Light source	8x white light LED, AC-, DC mode ¹⁾ (adjustable or OFF for self-luminous objects, software-switchable)				12x white light LED, AC-, DC mode ¹⁾ (adjustable bzw. OFF for self-luminous objects, software- switchable)	10x white light LED, modulated 30kHz
Type of illumination	focused					
Effect through illumination	Large dynamic range for matt/dark surfaces					
Ambient light	to 5000Lux (AC mode)					to 5000Lux
Intermittent light operation	AC: typ. 10kHz to 40kHz (depending on amplification level AMP1 to AMP8) DC: switchable by PC software					30kHz
Power supply	+24VDC (± 10%), inverse polarity protected, overload-proof					
Current consumption	typ. 320mA					
Max. switching current	100mA, short-circuit protected					
TEACH button/inputs	1 button and IN0 for external teaching of the color references					
Outputs	OUT 0 - OUT 4, digital (0V/+Ub), short-circuit protected, 100mA Max. switching current npn-, pnp-capable (bright or dark switching, switchable)					
Switching state display	Visualisation by means of 5 yellow LEDs					
Interface	RS232 (optional USB)					
Type of connector	to PLC: 8-pole flange socket (Binder series 712) to PC: 4-pole flange socket (Binder series 707)					to PLC: 8-pole flange socket (Binder 712) to PC: 5-pole flange socket (Binder 712) to power/PLC: art. no. 11234091 to PC: art. no. 11234092
Connection cable	to power/PLC: art. no. 11234091 / to PC: art. no. 11234095 (RS232); 11234096 (USB).					
Receiver	3-color filter detector (TRUE COLOR detector, color filter curve as per CIE 1931)					
Software	colorCONTROL S					Sicolor 4
Pulse extension	adjustable 0ms-100ms					
Signal amplification	8 stage (AMP1 - AMP8), adjustable					
Housing material	Aluminium, black anodised					
Operating temperature	-20°C - +55°C					
Storage temperature	-20°C - +85°C					
Protection class	IP67 (lens), IP64 (electronics)					IP64
EMC test according	DIN EN 60947-5-2					

¹⁾ suitable for illumination testing

Dimensions:

Dimensions in mm, not to scale

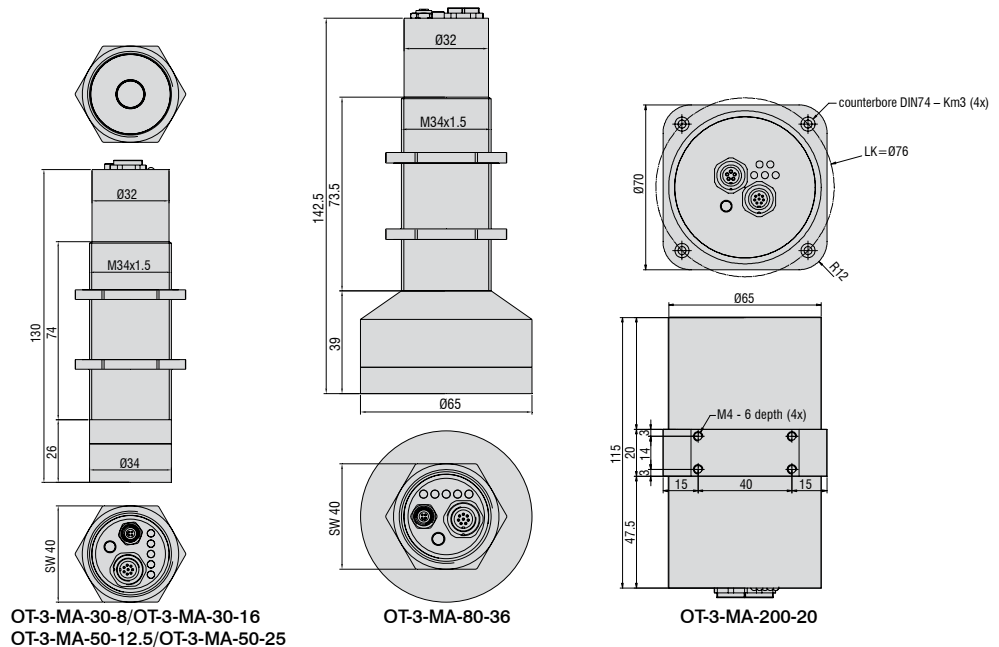

colorSENSOR OT-3-GL

Color control on non-homogeneous surfaces and shine suppression



- ▶ 31 colors can be saved
- ▶ Diffuse illumination for the reduction of the shine effect
- ▶ Color and grey scale evaluation
- ▶ PC programmable via RS232 / USB

Features:

- White light LED ring with diffusor and clear glass covering
- Object distance typ. 10mm - 300mm
- Suppression of the shine effect through diffuse illumination
- Color memory: 31 colors via Teach-in and software
- RS232 interface (USB adapter optional)
- Insensitive to external light up to 5000Lux
- Switchable brightness readjustment
- Switching frequency max. 30kHz
- A variety of evaluation algorithms can be activated, e.g. „BEST HIT“ mode
- Switching state display via 5 yellow LEDs
- Switchable averaging
- Color control of self-luminous objects

Application examples:

- Color recognition of textured and/or shiny surfaces
- Detection of color rings
- Recognizing color markings in the printing industry
- Inspection of packaging
- Sorting tasks on the basis of color
- Color control of self-luminous objects (LEDs, displays, etc.)

Type	OT-3-GL-30-8	OT-3-GL-30-16	OT-3-GL-50-12.5	OT-3-GL-50-25	OT-3-GL-80-36	OT-3-GL-200-20
Article number	10234073	10234074	10234075	10234076	10234077	10234078
Object distance	typ. 10mm-60mm ideal distance 30mm		typ. 20mm-80mm ideal distance 50mm		typ. 40mm-100mm ideal distance 80mm	typ. 50mm-300mm ideal distance 200mm
Light spot	Ø 4-14mm	Ø 8-28mm	Ø 5-20mm	Ø 10-40mm	Ø 30-40mm	Ø 5-30mm
Light spot diameter	Ø 8mm at 30mm	Ø 16mm at 30mm	Ø 12.5mm at 50mm	Ø 25mm at 50mm	Ø 36mm at 80mm	Ø 20mm at 200mm
Color difference	ΔE ≥ 0.5					ΔE ≥ 1.5
Color spaces	X/Y INT; s/i M (Lab)					
Averaging	more than max. 32768 values					
Size of the color memory	max. 31 colors in non-volatile EEPROM with parameter sets					
Switching frequency	max. 30kHz (depending on number of colors being taught and the setting for the averaging)					
Reproducibility	In the x,y color range, 1 digit each with 12-Bit-A/D conversion					
Temperature drift X,Y	< 0.01% /K					
Light source	8x white light LED, AC-, DC mode (adjustable or OFF for self-luminous objects, software-switchable)				12x white light LED, AC-, DC mode (adjustable or OFF for self-luminous objects, software-switchable)	10x white light LED, modulated 30kHz
Type of illumination	diffuse					
Effect through illumination	Suppression of the shine effect					
Ambient light	to 5000Lux (AC mode)					to 5000Lux
Intermittent light operation	AC: typ. 10kHz to 40kHz (depending on amplification level AMP1 to AMP8) DC: switchable by PC software					30kHz
Power supply	+24VDC (± 10%), inverse polarity protected, overload-proof					
Current consumption	typ. 320mA					
Max. switching current	100mA, short-circuit protected					
TEACH button/inputs	1 button and IN0 for external teaching of the color references					
Outputs	OUT 0 - OUT 4, digital (0V/+Ub), short-circuit protected, 100mA Max. switching current npn-, pnp-capable (bright or dark switching, switchable)					
Switching state display	Visualisation by means of 5 yellow LEDs					
Interface	RS232 (optional USB)					
Type of connector	to PLC: 8-pole flange socket (Binder series 712) to PC: 4-pole flange socket (Binder series 707)					to PLC: 8-pole flange socket (Binder 712) to PC: 5-pole flange socket (Binder 712)
Connection cable	to power/PLC: art. no. 11234091 to PC: 11234095 (RS232); Art. no. 11234096 (USB)					to power/PLC: 11234091 to PC: Art. no. 11234092
Receiver	3-color filter detector (TRUE COLOR detector, color filter curve as per CIE 1931)					
Software	colorCONTROL S					Sicolor 4
Pulse extension	adjustable 0ms-100ms					
Signal amplification	8 stage (AMP1 - AMP8), adjustable					
Housing material	Aluminium, black anodised					
Operating temperature	-20°C - +55°C					
Storage temperature	-20°C - +85°C					
Protection class	IP67 (lens), IP64 (electronics)					IP64
EMC test according	DIN EN 60947-5-2					

Dimensions:

Dimensions in mm, not to scale

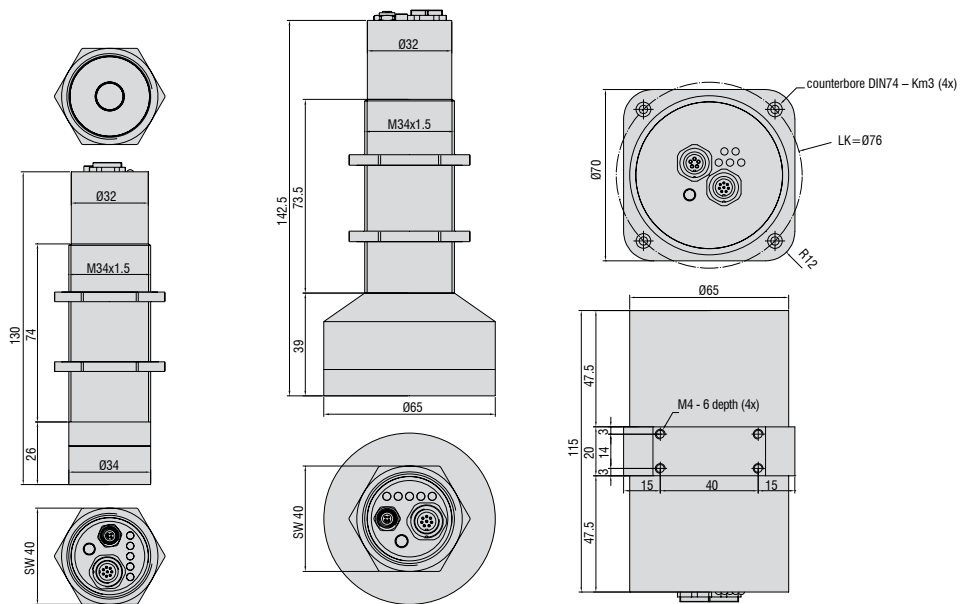

OT-3-GL-30-8/OT-3-GL-30-16
OT-3-GL-50-12.5/OT-3-GL-50-25

OT-3-GL-80-36

OT-3-GL-200-20

colorSENSOR OT-3-HR

Color sensor for reflective and textured surfaces



- ▶ 31 colors can be saved
- ▶ Polarized illumination for highly reflective surfaces
- ▶ Color and grey scale evaluation
- ▶ PC programmable via RS232 / USB

Features:

- White light LED ring with polarization filter and clear glass covering
- Object distance typ. 10mm - 300mm
- Polarization filter (significant reduction of the shine effect)
- Color memory: 31 colors via Teach-in and software
- RS232 interface (USB adapter optional)
- Insensitive to external light up to 5000Lux
- Switchable brightness readjustment
- Switching frequency max. 30kHz
- A variety of evaluation algorithms can be activated, e.g. „BEST HIT“ mode
- Switching state display via 5 yellow LEDs
- Switchable averaging
- Color control of self-luminous objects

Application examples:

- Color recognition of highly reflective and/or highly textured surfaces
- Detection of color rings
- Recognizing color markings in the printing industry
- Inspection of packaging
- Sorting tasks on the basis of color
- Color control of self-luminous objects (LEDs, displays, etc.)

Type	OT-3-HR-30-8	OT-3-HR-30-16	OT-3-HR-50-12.5	OT-3-HR-50-25	OT-3-HR-80-36	OT-3-HR-200-20
Article number	10234079	10234080	10234081	10234082	10234083	10234084
Object distance	typ. 10mm-40mm ideal distance 30mm		typ. 20mm-80mm ideal distance 50mm		typ. 40mm-100mm ideal distance 80mm	typ. 50mm-300mm ideal distance 200mm
Light spot	Ø 4-10mm	Ø 8-20mm	Ø 5-20mm	Ø 10-40mm	Ø 30-40mm	Ø 5-30mm
Light spot diameter	Ø 8mm at 30mm	Ø 16mm at 30mm	Ø 12.5mm at 50mm	Ø 25mm at 50mm	Ø 36mm at 80mm	Ø 20mm at 200mm
Color difference			ΔE ≥ 0.5			ΔE ≥ 1.5
Color spaces	X/Y INT; s/i M (Lab)					
Averaging	more than max. 32768 values					
Size of the color memory	max. 31 colors in non-volatile EEPROM with parameter sets					
Switching frequency	max. 30kHz (depending on number of colors being taught and the setting for the averaging)					
Reproducibility	In the x,y color range, 1 digit each with 12-Bit-A/D conversion					
Temperature drift X,Y	< 0.01% /K					
Light source	8x white light LED	8x white light LED	8x white light LED	8x white light LED	12x white light LED	10x white light LED modulated 30kHz
	AC-, DC mode (adjustable or OFF for self-luminous objects, software-switchable)					
Type of illumination	Polarization filter, focused					
Effect through illumination	Great reduction of the shine effect, ideal for highly reflecting surfaces					
Ambient light	to 5000Lux (AC mode)					to 5000Lux
Intermittent light operation	AC: typ. 10kHz bis 40kHz (depending on amplification level AMP1 to AMP8) DC: switchable by PC software					30kHz
Power supply	+24VDC (± 10%), inverse polarity protected, overload-proof					
Current consumption	typ. 320mA					
Max. switching current	100mA, short-circuit protected					
TEACH button/inputs	1 button and IN0 for external teaching of the color references					
Outputs	OUT 0 - OUT 4, digital (0V/+Ub), short-circuit protected, 100mA Max. switching current npn-, pnp-capable (bright or dark switching, switchable)					
Switching state display	Visualisation by means of 5 yellow LEDs					
Interface	RS232 (USB optional)					
Type of connector	to PLC: 8-pole flange socket (Binder series 712) to PC: 4-pole flange socket (Binder series 707)					to PLC: 8-pole flange socket (Binder series 712) to PC: 5-pole flange socket (Binder series 712)
Connection cable	to power/PLC: Art. no. 11234091 to PC: Art. no. 11234095 (RS232); 11234096 (USB)					to power/PLC: Art. no. 11234091 to PC: Art. no. 11234092
Receiver	3-color filter detector (TRUE COLOR detector, color filter curve as per CIE 1931)					
Software	colorCONTROL S					Sicolor 4
Pulse extension	adjustable 0ms-100ms					
Signal amplification	8 stage (AMP1 - AMP8), adjustable					
Housing material	Aluminium, black anodised					
Operating temperature	-20°C - +55°C					
Storage temperature	-20°C - +85°C					
Protection class	IP67 (lens), IP64 (electronics)					IP64
EMC test according	DIN EN 60947-5-2					

Dimensions:

Dimensions in mm, not to scale

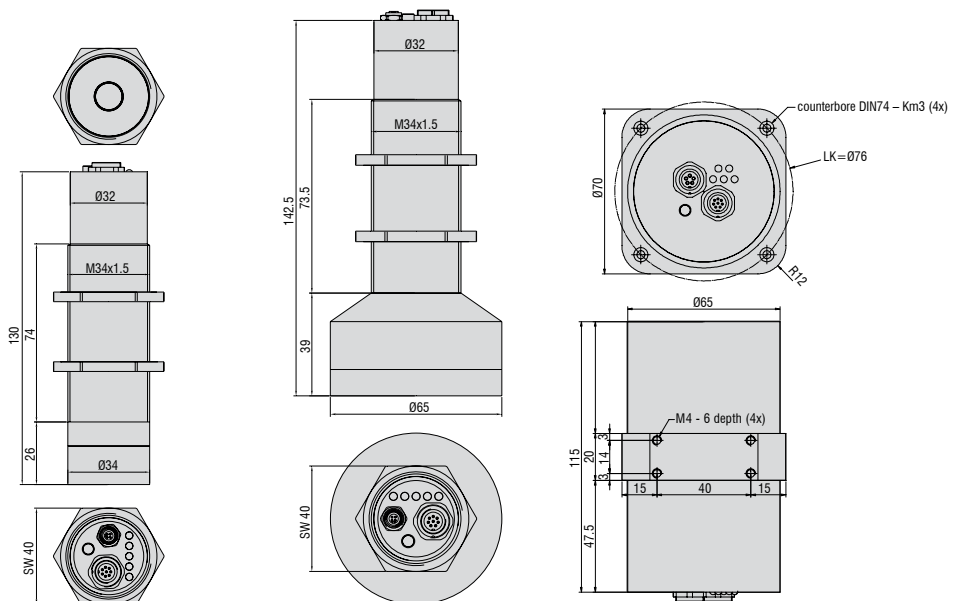

OT-3-HR-30-8/OT-3-HR-30-16
OT-3-HR-50-12.5/OT-3-HR-50-25

OT-3-HR-80-36

OT-3-HR-200-20

colorSENSOR OT-3-LD

Color sensor for large distances



- ▶ 31 colors can be saved
- ▶ Coaxial optics for large working distance up to 800mm
- ▶ Color and grey scale evaluation
- ▶ PC programmable via RS232 / USB

Features:

- Object distance typ. 50mm - 800mm
- Integrated receiver and transmitter optics (coaxial)
- Color memory: 31 colors via Teach-in and software
- RS232 interface (USB adapter optional)
- Super-bright white light LED
- Color, contrast and grey-scale detection
- Insensitive to external light up to 5000Lux
- Switchable brightness readjustment
- Switching frequency max. 35kHz
- A variety of evaluation algorithms can be activated e.g. „BEST HIT“ mode
- Switching state display via 5 yellow LEDs
- Temperature compensated ($< 0.01\% /K$)
- Switchable averaging
- Color control of self-luminous objects

Application examples:

- Color recognition from long distances up to 800mm
- Correct insertion of product in production machinery
- Inspection of packaging
- Sorting tasks on the basis of color
- Color assignment on automobiles
- Detecting drink crates
- Paper, recycling recognition
- Illumination recognition as per color and intensity

Type	OT-3-LD-500-23	OT-3-LD-500-50
Article number	10234085	10234086
Object distance	typ. 200mm-600mm ideal distance at 500mm	typ. 50mm-800mm ideal distance at 500mm
Light spot	Ø 9-27mm	Ø 5-80mm
Light spot diameter	Ø 23mm at 500mm	Ø 50mm at 500mm
Color difference	$\Delta E \geq 1.5$	
Color spaces	X/Y INT; s/i M (Lab)	
Averaging	more than max. 32768 values	
Size of the color memory	max. 31 colors in non-volatile EEPROM with parameter sets	
Switching frequency	max. 35kHz (depending on number of colors being taught and the setting for the averaging)	
Reproducibility	In the x,y color range, 1 digit each with 12-Bit-A/D conversion	
Temperature drift X,Y	< 0.01% /K	
Light source	Super-bright white light LED; AC-, DC- oder PULSE mode (adjustable or OFF for self-luminous objects, software-switchable) ¹⁾	
Type of illumination	Coaxial	
Effect through illumination	Large object distance	
Ambient light	to 5000Lux (in AC and PULSE mode)	
Intermittent light operation	AC: typ. to 20kHz (depending on amplification level AMP1 to AMP8) DC: typ. to 35kHz PULSE: typ. to 5kHz switchable by PC software	
Power supply	+24VDC ($\pm 10\%$), inverse polarity protected, overload-proof	
Current consumption	typ. 160mA	
Max. switching current	100mA, short-circuit protected	
TEACH button/inputs	1 button and IN0 for external teaching of the color references	
Outputs	OUT 0 - OUT 4, digital (0V/+Ub), short-circuit protected, 100mA Max. switching current npn-, pnp-capable (bright or dark switching, switchable)	
Switching state display	Visualisation by means of 5 yellow LEDs	
Interface	RS232 (optional USB)	
Type of connector	to PLC: 8-pole flange socket (Binder series 712) to PC: 4-pole flange socket (Binder series 707)	
Connection cable	to power/PLC: art. no. 11234091 / to PC: art. no. 11234095 (RS232); 11234096 (USB)	
Receiver	3-color filter detector (TRUE COLOR detector, color filter curve as per CIE 1931)	
Software	colorCONTROL S	
Pulse extension	adjustable 0ms-100ms	
Signal amplification	-	
Housing material	Aluminium, black anodised	
Operating temperature	-20°C - +55°C	
Storage temperature	-20°C - +85°C	
Protection class	IP67 (lens), IP64 (electronics)	
EMC test according	DIN EN 60947-5-2	

¹⁾ suitable for illumination testing

Dimensions:

Dimensions in mm, not to scale

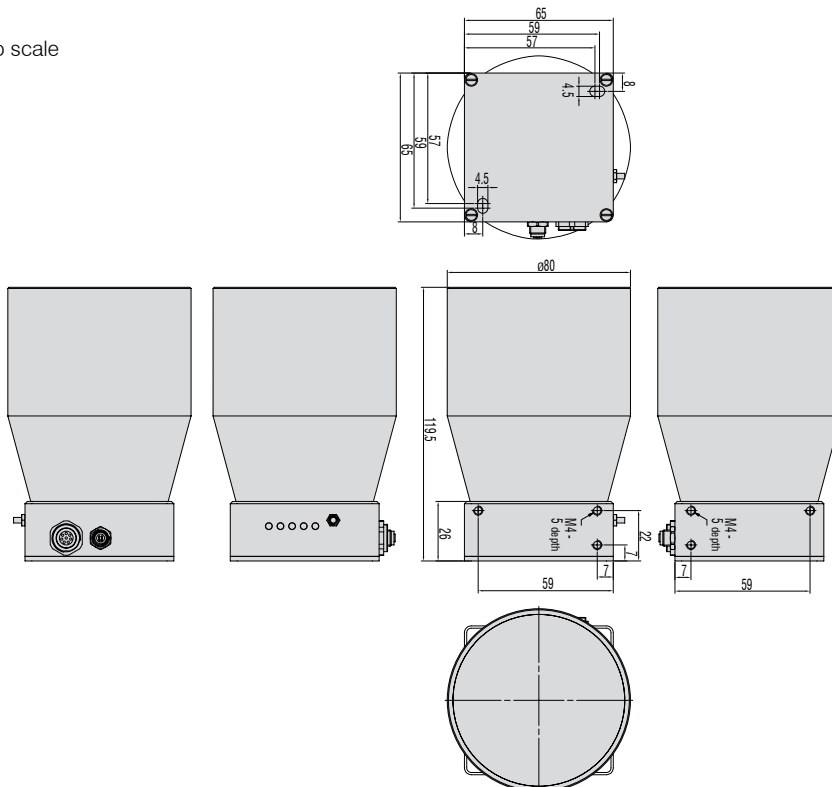

colorSENSOR OT-3-LU

Color sensor for fluorescent objects



- ▶ 31 colors can be saved
- ▶ UV illumination to detect luminescent colors
- ▶ Color and grey scale evaluation
- ▶ PC programmable via RS232 / USB

Features:

- UV-LED ring with black glass cover, 385nm
- Object distance typ. 10mm - 100mm
- Color memory: 31 colors via Teach-in and software
- RS232 interface (USB adapter optional)
- Recognition of different luminescent colors
- Insensitive to external light up to 5000Lux
- Switchable brightness readjustment
- Switching frequency max. 30kHz
- A variety of evaluation algorithms can be activated, e.g. „BEST HIT“ mode
- Switching state display via 5 yellow LEDs
- Switchable averaging

Application examples:

- Presence of the applied adhesive
- Detection of safeguarding thread
- Turbidity of liquids

Type	OT-3-LU-30-16	OT-3-LU-80-36
Article number	10234087	10234088
Object distance	typ. 10mm-40mm ideal distance 30mm	typ. 40mm-100mm ideal distance 80mm
Light spot	Ø 8-20mm	Ø 30-40mm
Light spot diameter	Ø 16mm at 30mm	Ø 36mm at 80mm
Color difference	$\Delta E \geq 0.5$	
Color spaces	X/Y INT; s/i M (Lab)	
Averaging	more than max. 32768 values	
Size of the color memory	max. 31 colors in non-volatile EEPROM with parameter sets	
Switching frequency	max. 30kHz (depending on number of colors being taught and the setting for the averaging)	
Reproducibility	In the x,y color range, 1 digit each with 12-Bit-A/D conversion	
Temperature drift X,Y	< 0.01% /K	
Light source	8x UV-LED, 385nm <small>AC-, DC mode (adjustable or OFF for self-luminous objects, software-switchable)</small>	12x UV-LED, 385nm <small>AC-, DC mode (adjustable or OFF for self-luminous objects, software-switchable)</small>
Type of illumination	UV 385nm, focused	
Effect through illumination	Luminescent colors	
Ambient light	to 5000Lux (AC mode)	
Intermittent light operation	AC: typ. 10kHz to 40kHz (depending on amplification level AMP1 to AMP8) DC: switchable by PC software	
Power supply	+24VDC ($\pm 10\%$), inverse polarity protected, overload-proof	
Current consumption	typ. 320mA	
Max. switching current	100mA, short-circuit protected	
TEACH button/inputs	1 button and IN0 for external teaching of the color references	
Outputs	OUT 0 - OUT 4, digital (0V/+Ub), short-circuit protected, 100mA Max. switching current npn-, pnp-capable (bright or dark switching, switchable)	
Switching state display	Visualisation by means of 5 yellow LEDs	
Interface	RS232 (optional USB)	
Type of connector	to PLC: 8-pole flange socket (Binder series 712) to PC: 4-pole flange socket (Binder series 707)	
Connection cable	to power/PLC: art. no. 11234091 / to PC: art. no 11234095 (RS232); 11234096 (USB).	
Receiver	3-color filter detector (TRUE COLOR detector, color filter curve as per CIE 1931)	
Software	colorCONTROL S	
Pulse extension	adjustable 0ms-100ms	
Signal amplification	8 stage (AMP1 - AMP8), adjustable	
Housing material	Aluminium, black anodised	
Operating temperature	-20°C - +55°C	
Storage temperature	-20°C - +85°C	
Protection class	IP67 (lens), IP64 (electronics)	
EMC test according	DIN EN 60947-5-2	

Dimensions:

Dimensions in mm, not to scale

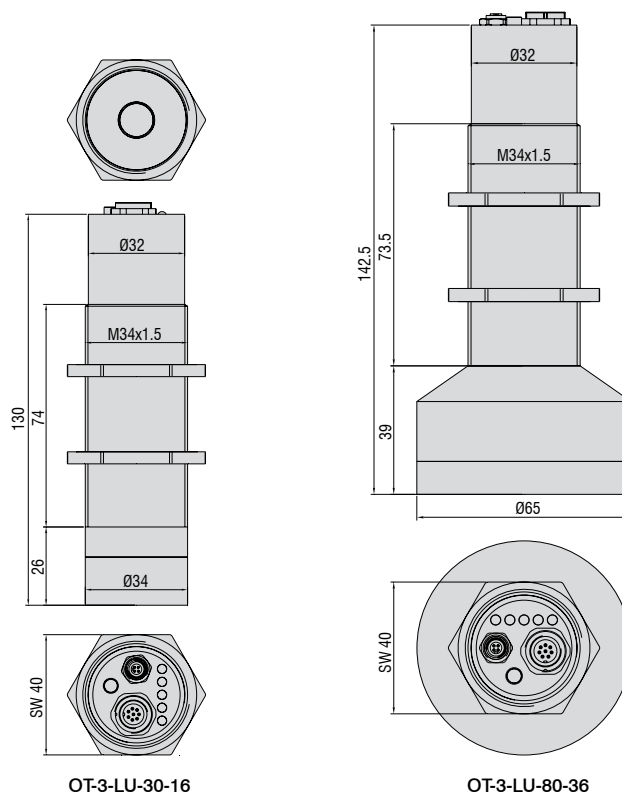

colorCONTROL MFA

Multiple-point color testing system



- ▶ Optionally with up to 100 channels
- ▶ Color testing in HSI and RGB color space
- ▶ Color differentiation/intensity test

Features:

- Universal connection of optical fibers
- Individual adaptation of the optical fiber configuration
- Each measuring point can be freely configurated to color, intensity and function
- Integration in test sequence
- Good/poor evaluation
- Output of HSI and RGB and XY values via RS232, USB and Ethernet
- External trigger
- Replaceable fiber optic adapter
- Suitable for POF (2m) and glass optical fibers up to 5m

Applications:

- Self-luminous object inspection
- LED test (binning)
- Indication test
- Display test
- 7 segment display inspection
- Checking up to 100 colors parallel and simultaneously $\leq 1s$
- Frontpanel test
- With external illumination, multiple-point Color testing is possible

Function:

The color, intensity and light information is fed directly from the measuring object to the MFA via single fiber bundles and evaluated at up to 100 points at the same time.

The inspection of inaccessible and/or remote systems is not difficult with the MFA series, because the information is transmitted to the intelligent evaluation system via fiber optics.

More than 100 measurement points can be defined by the adapter. Which measuring point is checked and output via Ethernet is defined by the colorCONTROL MFA software.

Type	MFA-5-P	MFA-5-M ¹⁾	MFA-55/100-C1	MFA-55/100-C2
Article number	11094052	11094050/11094051	11093903/11094200	11093623/11093518
Measuring points	5	5/10/15/20	55/100	55/100
Power supply	5VDC		24VDC +/- 10% residual ripple	
Current consumption	80mA	80mA-320mA	typ. 160mA-350mA	
Interface	RS232, USB, daisy chain		RS232, Ethernet	
Inputs	-	-	1 trigger input	
Outputs	-	-	1 total good (IO) - output	
	-	-	1 Total poor (IO) - output	
	-	-	1 Test over - output	
Photo Receiver	5x True Color photochip	5x True Color photochip	1/3" Color CCD	1/3" Color CCD
Accuracy	±4nm	±4nm	±10nm	±8nm to ±10nm
Resolution	9-81 pixels per measuring point	9-81 pixels per measuring point	66-113 pixels per measuring point	17-290 pixels per measuring point
Data memory	-	-	3 MB Flash-EEPROM	
Object distance				typ. 1-5mm
Optical fiber	incl. POF 0.5m; max. POF 2m / glass 5m		max. POF 2m / glass 5m	
Color space	HSI, RGB, XY + color temperature in K		HSI, RGB	
Dynamic range	200lx - 4000lx			
Testing frequency	≤1Hz (100 Measuring points ≤1s)			
Operating temperature	0 to +50°C		0 to +45°C	
Humidity	20% to 80% rel. humidity (non-condensing)			
Protection class	IP 0		IP 50	

¹⁾ Modular extension to 10/15/20 measuring points

Dimensions:

Dimensions in mm, not to scale

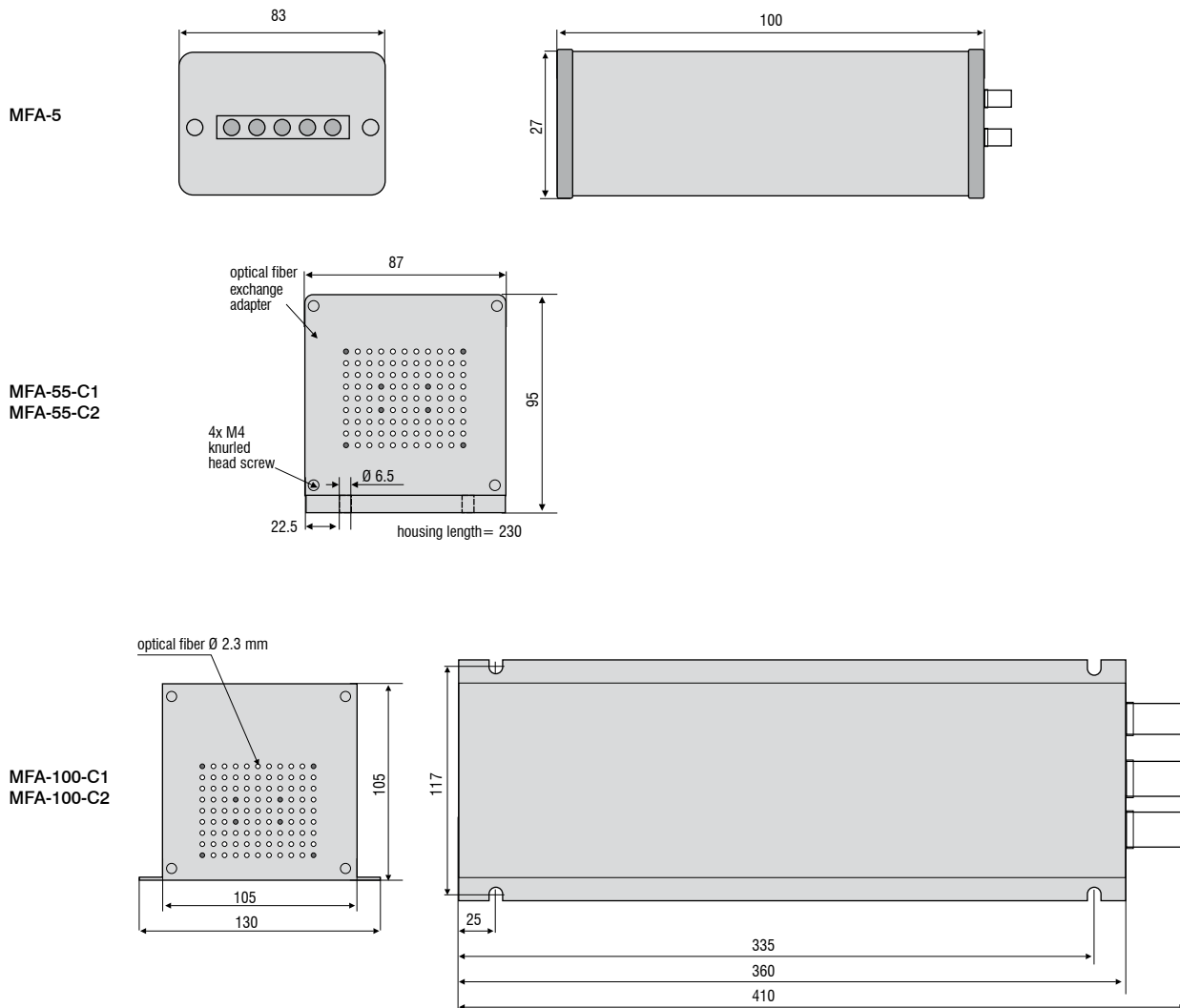

Glass fiber light guides

for colorSENSOR

Order code for optical fiber

You can see an overview of the Fasop optical fiber range on the following pages.

You can define your own individual fiber optic light guides from the various components using the order key.

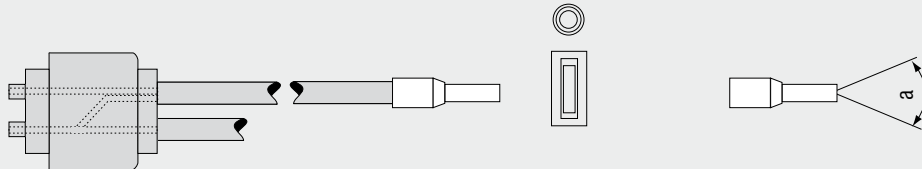

Ordering code: **FA D T A 2.0 2.5 1200 67°**

1 2 3 4 5 6

- 1** Adaption to devices e.g. to FA-Adapter for the CLS series, or color sensors of the colorSENSOR LT and WLCS-M series
- 2** Function of the optical fiber (D = transmitted light mode, R = reflex mode)
- 3** Sheathing e.g. silicone-metal sheath (T)
- 4** Sensor mechanism type, e.g. A2.0
Fiber bundle e.g. 2.5mm dia.
- 5** Overall length of e.g. 1200mm (standard length / bearing types)
- 6** Aperture angle of the fiber, e.g. 67°

Technical data for FASOP optical fibers

Single fiber diameter	20, 30, 50, 70µm standard fiber (depending on structure)	
Aperture angle	Standard fibers	67° (NA 0,56)
	Special fibers	22° (NA 0.21) 121° (NA 0.87 / wide angle) 22° UV (80/100µm) 22° IR (80/100/150µm)
Material	Optical glass (e.g. for UV / IR / in quartz glass)	
Dielectric strength	50kV/m with PVC protective sheath	
Permissible temperature range with sheathing that has appropriate fiber bonding	PVC	-20°C to +80°C (P) (Z)
	Metal	+40°C to +180°C (M)
	Metal with special bonding	-40°C to +400°C (E)
	Metal/silicone	-40°C to +180°C (T)
Fiber transmission	Usable for wavelengths from 190-2500nm of different types (We can provide the most suitable solution depending on the requirements) Transmission curves on request!	

1 Adapter version

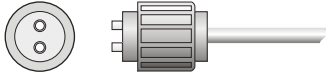

Adaption for:
Optical fiber light barriers:
 Series RLS, CLS, IFA, TLB
Color sensors:
 Series FES-M, WLCS

FA

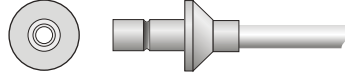

FOT **Adaption for light source:**
 Series FEL-M, FEL-I, FOT

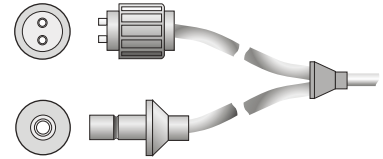

FE **Adaption for color sensors with additional light source:**
 Series FES-M

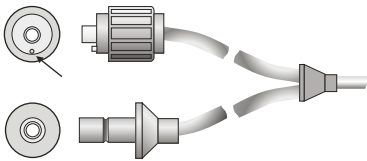

FW **Adaption for color recognition:**
 Series FAG-I-80, FEG-I-18/28

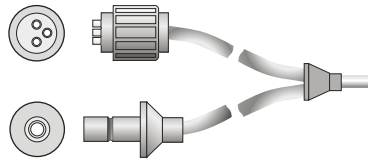

FF **Adaption for color recognition:**
 Series FAG-I-8, FEG-I-10/20

2 Functions

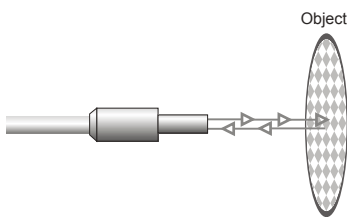

R **Reflected light operation (button)***

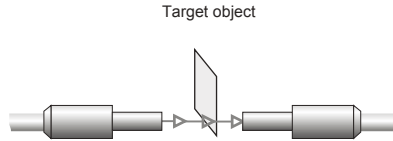

D **Transmitted light operation (barrier)***

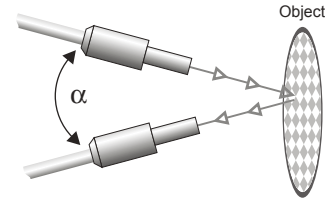

D **Transmitted light operation (V arrangement) for reflective and shiny surfaces**

* All functions can also be performed as multiple reflex and transmitted light functions

3 Sheathing

Silicone metal sheath

Metal wire-spiral-reinforced hose with glass fiber braiding and silicone rubber sheathing



Characteristics
 Very flexible, highly resistant to bending, tension and torsion; temperature-stable to 180°C, liquid-tight

T

Stainless-steel sheath

Flexible stainless steel wire-spiral-reinforced hose ¹⁾



Characteristics
 Flexible, protection against mechanical stress, temperature-stable to 400°C

E

Metal sheath

Flexible brass wire-spiral-reinforced hose ¹⁾



Characteristics
 Flexible, protection against mechanical stress, temperature-stable to 180°C

M

¹⁾ Bending radius corresponds to three times the external diameter of the sheath.
²⁾ Bending radius corresponds to twice the external diameter of the sheath.

Details of sheath diameters can be found in Section 4:

Please note: Every version can be supplied with increased vibration protection (VS). See the „Special versions“ section for more information

PVC-metal sheath

Flexible brass spiral-reinforced hose coated with PVC sheathing ¹⁾

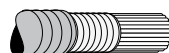

Characteristics
 Flexible, protection against mechanical stress, temperature-stable to 80°C

Z

PVC special sheath

Highly flexible plastic hose ²⁾



Characteristics
 highly flexible, small sheath diameter, temperature-stable to 80°C

P

4 Sensor mechanism variants and fiber bundles

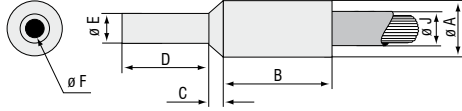

Type	A Ø	B	C	D	E Ø	F Ø	P	Ø J M	T
A 1.0	4.6	8	2	11	2.5	1.5	4	4	-
A 1.1	6.6	8	2	11	2.5	1.5	-	5	4.4
A 2.0	6.6	10	2	12	4.5	2.5	6	6	5.8
A 3.0	8.5	11	2	15	6	3	7	7	7.5

A Type A ferrule, stainless steel

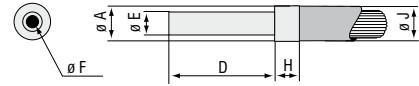

Type	A Ø	D	E Ø	F Ø	H	Ø J P	Ferrule
B 1.1	2	30	1	0.6	2	2	stainless steel
B 1.2	2	10	1	0.6	2	2	stainless steel
B 2.0	3	10	2	1	2	3	alu
B 3.0	5	12	4	2.5	2	5	alu
B 4.0	8	12	6	3	2	8	alu

B Type B ferrule
(only suitable for PVC sheathing)

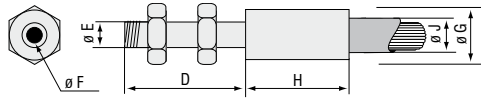

Type	D	E	F Ø	G Ø	H	P	Ø J M	T
C 1.0	30	M4	1.0	6	13	5	5	4.4
C 2.0	30	M6	2.5	8	15	6	6	5.8
C 3.0	30	M10	3	11	12	7	7	7.5

C Type C ferrule, stainless steel

All details in mm
Tolerances: typ. +/- 0.1mm
Al ferrule, black anodised

**Different sizes are possible by arrangement,
please ask our product specialists.**
(see also the „Special versions“ section)

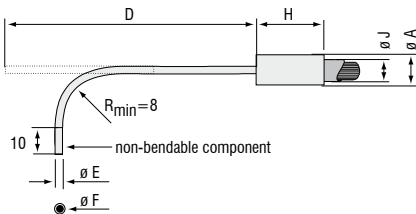

Type	A Ø	D	E Ø	F Ø	H	P	Ø J M	T
O 1.0	2	100	1	0.6	10	2	-	-
O 1.1	7	100	1	0.6	20	-	5	4.4
O 2.0	3	100	1.3	1	10	3	-	-
O 2.1	7	100	1.3	1	20	-	5	4.4

O Type O ferrule
Bendable, to an extent

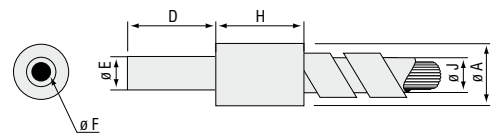

Type	A Ø	D	E Ø	F Ø	H	Ø J M	T	Ferrule
M 1.1	6	30	1	0.6	10	5	4.4	stainless steel
M 1.2	6	10	1	0.6	10	5	4.4	stainless steel
M 2.0	6	10	2	1	10	5	4.4	alu
M 3.0	7	12	4	2.5	12	6	5.8	alu
M 4.0	9	12	6	3.5	12	7	7.5	alu
M 5.0	12	16	7	5	16	9	9	alu
M 6.0	13	16	8	6	18	10	11.5	alu
M 8.0	16	20	10	8	20	13	13.5	alu
M10.0	18	20	12	10	20	15	-	alu

M Type M ferrule

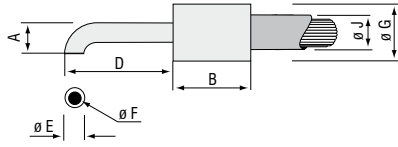

Type	A Ø	B	D	E Ø	F Ø	G Ø	r	P	Ø J M	T
D 1.0	2.5	10	20	1	0.6	3	1.5	2	-	-
D 1.1	2.5	13	20	1	0.6	6	1.5	-	-	4.4
D 2.0	6	13	20	2	1.5	6	4	5	5	4.4
D 3.0	15	17	20	5	2.5	9	10	7	7	6.5

D Type D ferrule, stainless steel
(* D1.0 only suitable for PVC sheathing)

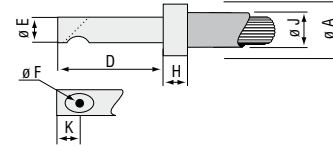

Type	A Ø	D	E Ø	F Ø	H	K	P	Ø J M	T
E 1.0	4	20	3	1.5	1.5	4	4	-	-
E 2.0	5	20	4	2.5	1.5	4	5	5	-
E 2.1	7	20	4	2.5	10	4	-	-	5.8
E 3.0	8	20	6	3	1.5	5	7	7	-

E Type E ferrule, stainless steel
(* E1.0 only suitable for PVC sheathing)

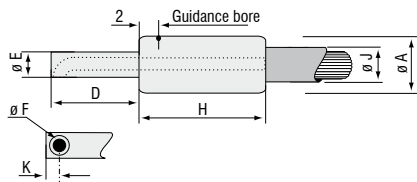

Type	A Ø	D	E Ø	F Ø	H	K	P	Ø J M	T
F 1.0	8	20	6	1.5	9	3	5	5	5.8
F 2.0	10	20	8	2.5	10	4	6	6	6.5
F 3.0	12	20	10	3	10	5	7	7	7.5

F Type F ferrule, stainless steel

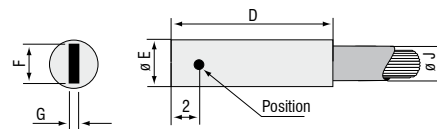

Type	D	E Ø	F	G max.	P	Ø J M	T
R 1.0	25	4	3	0.5	3	-	-
R 1.1	30	7	3	0.5	6	6	5.8
R 2.0	25	7	6	1	6	6	5.8**
R 2.1	30	10	6	1	-	7	7.5

R Type R ferrule, aluminium
* R1.0 only suitable for PVC sheathing
** at 6x1 mm², can be made to a length of 1200

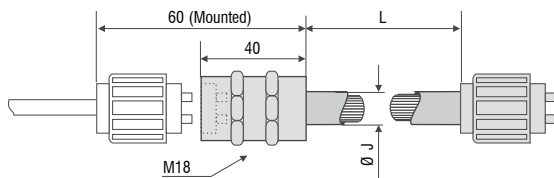

Fiber bundle Ø (3mm)/ channel	P	Ø J M	T	L
	12	13	13.5	

LV Type LV ferrule
Optical fiber extension / feed-through

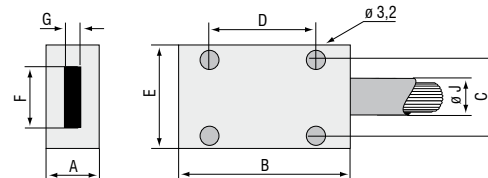

Typ	A	B	C	D	E	F	G	Ø J
Q1	12	25	9	15	15	5	0.5	dependent on fiber cross-section
Q2	12	30	14	20	20	10	0.3	
Q3	12	35	24	25	30	18	0.3	
Q4	12	55	34	40	40	28	0.2	
Q5	12	55	44	40	50	38	0.15	
Q6	12	55	54	40	60	48	0.15	
Q7	16	75	64	60	70	58	*	
Q8	16	75	74	60	80	68	*	
Q9	20	90	84	75	90	78	*	
Q10	20	90	94	75	100	88	*	

(F x G 3.5 mm² for CLS and IFA applications with FA adapter)

Q Type Q, aluminium
also available in stainless steel

All details in mm
Attention: With angular sensor mechanism versions, a reduction in range can be expected compared to axially emerging versions.

5 + 6 Length and aperture angle



Standard lengths are: 600*, 1200*, 1800 and 2400mm.
 * Bearing types
 Length tolerance type: +/- 4%
 Cable lengths of up to 30m can be supplied on request!

5

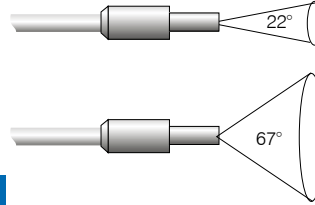

Dependent on the glass fiber material used the following aperture angles are included in the standard range: 22°, 67°, 121°

6

Adapter

Adapter Type	Ferrule Dim. E Ø	Fits ferrules	Art. no.
A	2.5	A1.0, A1.1	10820552
B	4	B3.0, M3.0, R1.0	10821562
C	6	A3.0, B4.0, M4.0	10821119
C	6	M1.1, M1.2, M2.0 *	10821119
H	4.5	A2.0	10821561
C2	M6	C2.0 (optional C3.0)	10822628

* These ferrules fit in the adapter, size A diameter (collar size)

Adapter pieces for focus lenses

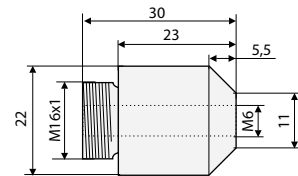

Adapter piece

Suitable for FLF-B-35 focus lens

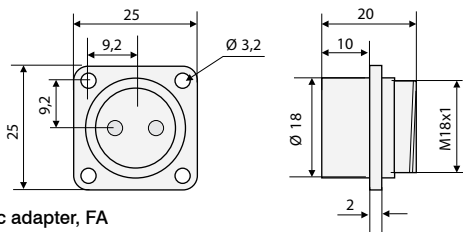

Fiber optic adapter, FA
Front panel mounting

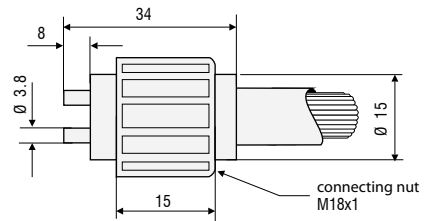

Adapter, FA
System FASOP

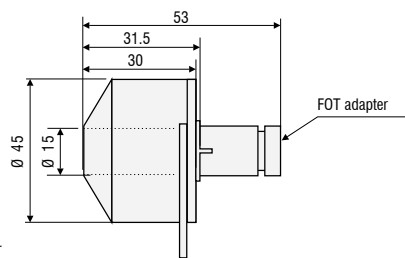

Color filtered head
for FOT optical fiber

Special versions

■ Optical fibers with increased vibration protection

Glass fibers are very flexible due to their small diameter and they can be bent or guided almost at will. However, glass fibers can break due to hard shocks or jerky movements (strong positive or negative accelerations). Especially for fiber optic, which are subject to these conditions, our glass fiber series makes it possible to produce fiber-optic cables with increased vibration protection. Friction between the glass fibers is minimized by a special treatment and shocks are reduced by damping. (Additional designation VS) When ordering an optical fiber with increased vibration protection, please add the abbreviation „VS“ to the optical fiber code.

■ Optical fibers with special bonding for high temperatures (T250) (T400) (T600)

The glass fibers can be bonded for high temperature ranges. The standard bonding is suitable for temperatures up to 80°C. Temperatures of up to 250°C and even 400°C can be reached when special adhesives are used. For higher temperature ranges it is necessary to use Type E stainless steel sheathing.

When ordering an optical fiber for high temperatures, please add the abbreviations „T250“ or „T400“ to the optical fiber code.

Temperatures of up to 600°C can be reached with metallic fibers and with sapphire optics installed.

■ Different types of fiber

Other types of fiber can be supplied on request. These include UV fibers, special infrared fibers, wide-angle fibers or plastic fibers.

■ Customer-specific glass fiber optical fibers

One of the strengths of the Micro-Epsilon Eltrotec optical fiber production is the manufacturing of very complex fibers, both large and small sensor mechanisms (with multiple segments and special adapters, among other things). Micro-Epsilon-Eltrotec can draw on many years of experience in the fields of sensor technology and cold light illumination, as well as in illumination for cameras, microscopes and medical applications, and in endoscopy.

Series KL-xx/xx



- ▶ Focussing of color and optical fiber sensors
- ▶ Improving the efficiency of the application
- ▶ Many possible applications

Features:

- Working distances from 8mm to 200mm
- Scratch-resistant glass lens
- Robust aluminium housing (black anodized)
- Bundling to a small light spot
- Increasing the range
- Minimum color change when the distance is altered
- High luminous efficiency
- Special designs possible, according to customer requirements
- Color measurement on small objects at a relatively large distance (KI-3, KL-4)
- Recognizing highly absorbent objects (KL-5, KL-14, KL-17)

	Type	Article number	Object distance (typ.)	Detection range (typ.)*	LWL FASOP
	KL-3	10823012	8mm - 20mm	1mm - 5mm	A 2.0 ¹⁾
	KL-M18-A2.0	10823020	15mm - 50mm	2mm - 10mm	A 2.0 ¹⁾
	KL-M34	10823278	80mm - 150 mm	10mm - 20mm	A 2.0 ¹⁾
	KL-M34/62	10824196	80mm - 150 mm	2mm - 5mm	A 2.0 ¹⁾
	KL-4	10823262	8mm - 20mm	0.6mm - 3mm	A 1.1 ¹⁾
	KL-M18-A1.1	10824140	10mm - 50mm	2mm - 7mm	A 1.1 ¹⁾
	KL-D-40	10824143	15mm - 25mm	3mm - 5mm	A 2.0 ²⁾
	KL-D-28	10824197	20mm - 30mm	5mm - 8mm	A 2.0 ²⁾
	KL-D-20	10823021	20mm - 40mm	4mm - 10mm	A 2.0 ²⁾
	KI-D-17	10823220	30mm - 80mm	8mm - 25mm	A 2.0 ²⁾
	KL-D-14	10823022	60mm - 120mm	10mm - 20mm	A 2.0 ²⁾
	KL-D-6	10823409	100mm - 200mm	15mm - 30mm	A 2.0 ²⁾
	KL-5	10824198	8mm - 20mm	2mm x 0.3mm to 15mm x 3mm	R 1.1 ¹⁾
	KL-8	10823920	8mm - 20mm	4mm x 0.7mm to 30mm x 5mm	R 2.1 ¹⁾

*The smallest figure in the table relates to the smallest typical optical diameter that is generated. This corresponds to roughly the smallest detection area for color or optical fiber sensors.

¹⁾ Reflex optical fiber (FAR)

²⁾ Transmitted light mode fiber optical cables (FAD)

Cables and other accessories

colorSENSOR accessories		
Art. no.	Description	suitable for:
11234089	CAB-M23-19P-Bu-ge; 2m-PUR; open	colorSENSOR WLCS M-41 (power and PLC)
11234090	CAB-M9-3P-St-ge; 2m-PUR; RS232	colorSENSOR WLCS M-41 (RS232)
11234091	CAB-M9-8P-St-ge; 2m-PUR; open	colorSENSOR LT and OT series (power and PLC)
11234092	CAB-M9-5P-St-ge; 2m-PUR; RS232	colorSENSOR OT-3-XX-200 (RS232)
11234093	CAB-M9-4P-St-ge; 2m-PVC; RS232	colorSENSOR LT-1-ST; LT-2-XX (RS232)
11234094	CAB-M9-4P-St-ge; 2m-PVC; USB	colorSENSOR LT-1-ST; LT-2-XX (USB)
11234095	CAB-M5-4P-St-ge; 2m-PUR; RS232	colorSENSOR LT-1-LC-20; LT-3; OT-3 series (RS232)
11234096	CAB-M5-4P-St-ge; 2m-PVC; USB	inc. RS232 to USB adapter suitable for: colorSENSOR LT-1-LC-20; LT-3; OT-3 series (USB)
11234097	CAB-M23-19P-Bu-ge; 5m-PUR; open	colorSENSOR WLCS M-41 (power and PLC)
11234098	CAB-M9-3P-St-ge; 5m-PUR; RS232	colorSENSOR WLCS M-41 (RS232)
11234099	CAB-M9-8P-St-ge; 5m-PUR; open	colorSENSOR LT and OT series (power and PLC)
11234100	CAB-M9-5P-St-ge; 5m-PUR; RS232	colorSENSOR OT-3-XX-200 (RS232)
11234101	CAB-M9-4P-St-ge; 5m-PVC; RS232	colorSENSOR LT-1-ST; LT-2-XX (RS232)
11234102	CAB-M9-4P-St-ge; 5m-PVC; USB	colorSENSOR LT-1-ST; LT-2-XX (USB)
11234103	CAB-M5-4P-St-ge; 5m-PUR; RS232	colorSENSOR LT-1-LC-20; LT-3; OT-3 series (RS232)
11234104	CAB-M5-4P-St-ge; 5m-PVC; USB	inc. RS232 to USB adapter suitable for: colorSENSOR LT-1-LC-20; LT-3; OT-3 series (USB)

colorCONTROL accessories		
10814105	POF-2.2mm optical fiber	colorCONTROL MFA
11251112	Threaded ferrule; LWL; M4	POF-2.2
11251113	Mounted lens 6mm	Threaded ferrule; LWL; M4
11253931	Threaded ferrule; 3mm lens; LWL; M4	POF-2.2
11254108	Threaded ferrule; 90° optics; LWL; M5	POF-2.2
11294106	CAB-M9-8P-Bu-ge; 2m-PUR; open	colorCONTROL MFA-55/100 (power and PLC)
11294107	CAB-M9-5P-Bu-ge; 2m-PUR; Ethernet	colorCONTROL MFA-55/100 (Ethernet)
11294109	CAB-M9-8P-Bu-ge; 5m-PUR; open	colorCONTROL MFA-55/100 (power and PLC)
11294110	CAB-M9-5P-Bu-ge; 5m-PUR; Ethernet	colorCONTROL MFA-55/100 (Ethernet)
11293227	Connection cable, Cross Ethernet Adapter; 0.5m	colorCONTROL MFA-55/100
11293624	colorCONTROL MFA 55 exchange adapter	colorCONTROL MFA-55
11293519	colorCONTROL MFA 100 exchange adapter	colorCONTROL MFA-100
11294205	CAB-M9-2P-Bu-ge; 2m-PUR; open	colorCONTROL MFA-5 (power)
11294206	CAB-M9-2P-Bu-ge; 5m-PUR; open	colorCONTROL MFA-5 (power)
11234094	CAB-M9-4P-St-ge; 2m-PVC; USB	colorCONTROL MFA-5 (USB)
11234102	CAB-M9-4P-St-ge; 5m-PVC; USB	colorCONTROL MFA-5 (USB)
11234095	CAB-M5-4P-St-ge; 2m-PUR; RS232	colorCONTROL MFA-5 (RS232)
11234103	CAB-M5-4P-St-ge; 5m-PUR; RS232	colorCONTROL MFA-5 (RS232)
11294203	CAB-female connector strip-6P-ge; 1m-PVC; 2P-open	colorCONTROL MFA-5-P (power)
11294054	CAB-female connector strip-6P-ge; 1m-PVC; USB	colorCONTROL MFA-5-P (USB and power)
11294204	CAB-female connector strip-6P-ge; 1m-PVC; RS232	colorCONTROL MFA-5-P (RS232)

Pin assignment

CAB-M9-8P-St-ge; Xm-PUR; open
(Anr.: 11234091; 11234098)

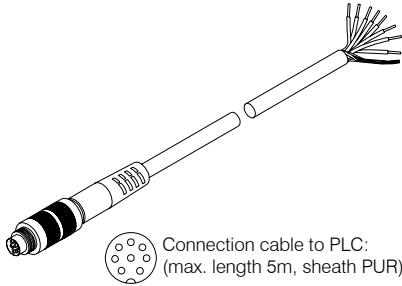

Connection cable to PLC:
(max. length 5m, sheath PUR)

Pin	Color	LT-1- LC-10 / ST	SB1 LT-2- ST / DU	SB2 LT-2- ST / DU	LT-1-LC-20 LT-3-XX OT-3-XX
1	white	OUT 0	n.c. / OUT A 0	OUT 1	GND (0V)
2	brown	OUT 1	n.c. / OUT A 1	OUT 2	+24VDC ($\pm 10\%$)
3	green	IN 1	IN 1	OUT 3	IN 0
4	yellow	IN 0	IN 0	OUT 4	OUT 0
5	grey	n.c. / OUT 4	CLK (OUT K)	OUT 5	OUT 1
6	pink	OUT 3	n.c. / OUT A 2	OUT 6	OUT 2
7	blue	GND (0V)	GND (0V)	OUT 7	OUT 3
8	red	+24VDC ($\pm 10\%$)	+24VDC ($\pm 10\%$)	OUT 0	OUT 4

CAB-M23-19P-Bu-ge; Xm-PUR; open
(Anr.: 11234089; 11234097)

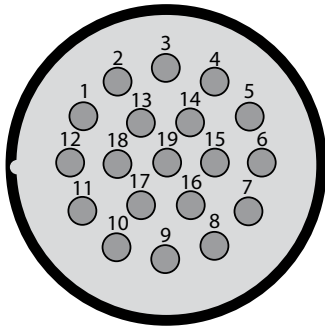

Pin	Color	WLCS-M-41
1	green	IN TF
2	grey	OUT Int. OK
3	pink	n.c.
4	red	OUT 4
5	white	OUT 2
6	blue	GND (0V)
7	violet	n.c.
8	grey/pink	n.c.
9	red/blue	IN HOLD
10	white/green	IN 1
11	brown/green	IN 2
12	yellow	PE
13	white/yellow	Common
14	-	-
15	black	OUT 1
16	yellow/brown	OUT 3
17	white/grey	IN 3
18	grey/brown	IN 4
19	brown	+24VDC ($\pm 10\%$)

CAB-M9-8P-Bu-ge; Xm-PUR; open
(Anr.: 11294106; 11294109)

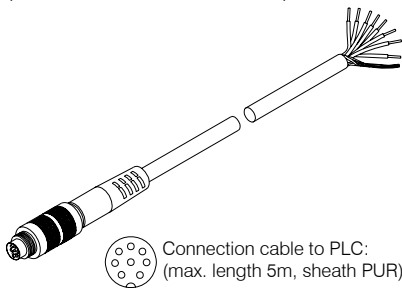

Connection cable to PLC:
(max. length 5m, sheath PUR)

Pin	Color	MFA 55/100
1	white	IN 0
2	brown	+24VDC ($\pm 10\%$)
3	green	n.c.
4	yellow	OUT 0
5	grey	OUT 1
6	pink	OUT 2
7	blue	GND (0V)
8	red	OUT 3

High performance sensors made by Micro-Epsilon



Sensors and systems for displacement and position



Sensors and measurement devices for non-contact temperature measurement

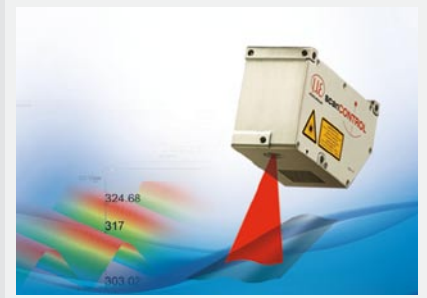

2D/3D profile sensors (laser scanner)

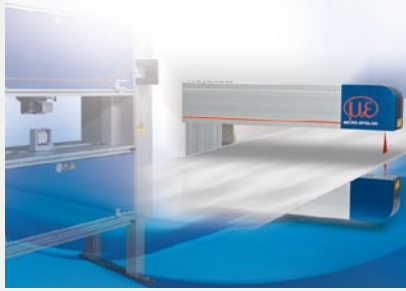

Measurement and inspection systems for quality assurance



Optical micrometers and optical fibers



Color recognition sensors and LED analyzers