

7 MOVIGEAR®-SNI

	TIPS
	<p>This catalog provides a brief overview of MOVIGEAR® drive units for a quick drive selection.</p> <p>For detailed descriptions, project planning information and dimension drawings, refer to the "MOVIGEAR®-SNI" system manual.</p>

7.1 Description

MOVIGEAR® is a compact mechatronic drive system comprising a gear unit, a motor and drive electronics.

It has an advantageous, compact design and is ideal for ensuring that conveyor systems are structured as efficiently as possible.

MOVIGEAR® provides a high level of system efficiency contributing to reducing the overall energy expenses. The integration and coordination of all drive components makes for a long service life and high system availability.

MOVIGEAR® is an intelligent system with its own control concept. Its high-quality networking features help reduce the startup time and support the monitoring and maintenance tasks.

The following figure shows the MOVIGEAR® drive units (left: torque class MMGF4, right: MGF2):



758839563

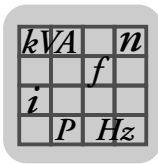

7.1.1 Unit properties

- Wide voltage range 3 × AC 380 V ... AC 500 V
- High overload capacity for all sizes
- 4Q capability due to integrated brake chopper and BW1 braking resistor installed as standard
 For the regenerative load capacity of BW1, refer to section "4Q operation with integrated BW.. braking resistor" (see page 239).
- Line filter integrated as standard. EMC-compliant installation ensures compliance with limit class C3 to EN 61800-3 (class A, group 2 according to EN 55011).
- LED display for operating and fault states
- Protective features for complete protection of the frequency inverter and motor (short-circuit, overload, overvoltage/undervoltage, excess temperature in the frequency inverter, excess temperature in the drive unit).
- Speed monitoring
- Ramp switch-over
- Fault memory (5 memory locations) with all relevant operating data at the time of the fault
- Elapsed-time counter for hours of operation (unit connected to supply system) and enable hours (output stage energized)

7.1.2 Advantages of MOVIGEAR®

- Compact design: Motor, gear unit and electronics are combined in a single mechatronic drive system
- High breakaway and starting torques
- Simplified system planning and design
- A reduction in the number of variants enables the development and design of standard materials handling systems with ready-made and tested standard modules.
- Functional user software
- The power of the drive engineering components is optimized to suit the application
- Reduction in storage due to reduced number of variants
- High degree of protection
- Hygienic surface design for applications in hygienic areas
- No air, dirt and germ swirls
- Low noise emission due to operation without fans (suitable for use in manual work stations)
- Reduced energy costs due to high efficiency of all components (gear unit, motor, electronics)
- High degree of reliability due to systematic development of all components
- Reduced total costs and operating costs of the materials handling system
- Single Line Installation (see page 248) principle: Only one cable has to be installed for energy and information transfer

kVA	n
	f
i	
P	H_z

7.2 Available MOVIGEAR® drive units

7.2.1 MOVIGEAR® drive units

MOVIGEAR® is available in two sizes and two mechanical designs.

- MOVIGEAR® sizes**
- MGF.2 (torque class: 200 Nm)
 - MGF.4 (torque class: 400 Nm)

- MOVIGEAR® design types**
- MOVIGEAR® with hollow shaft and keyway
 - MOVIGEAR® with TorqLOC® hollow shaft mounting system

Examples The following figure shows a MOVIGEAR® MGFT.2 unit with TorqLOC® hollow shaft mounting system and a MOVIGEAR® MGFA.4 unit with hollow shaft and keyway:

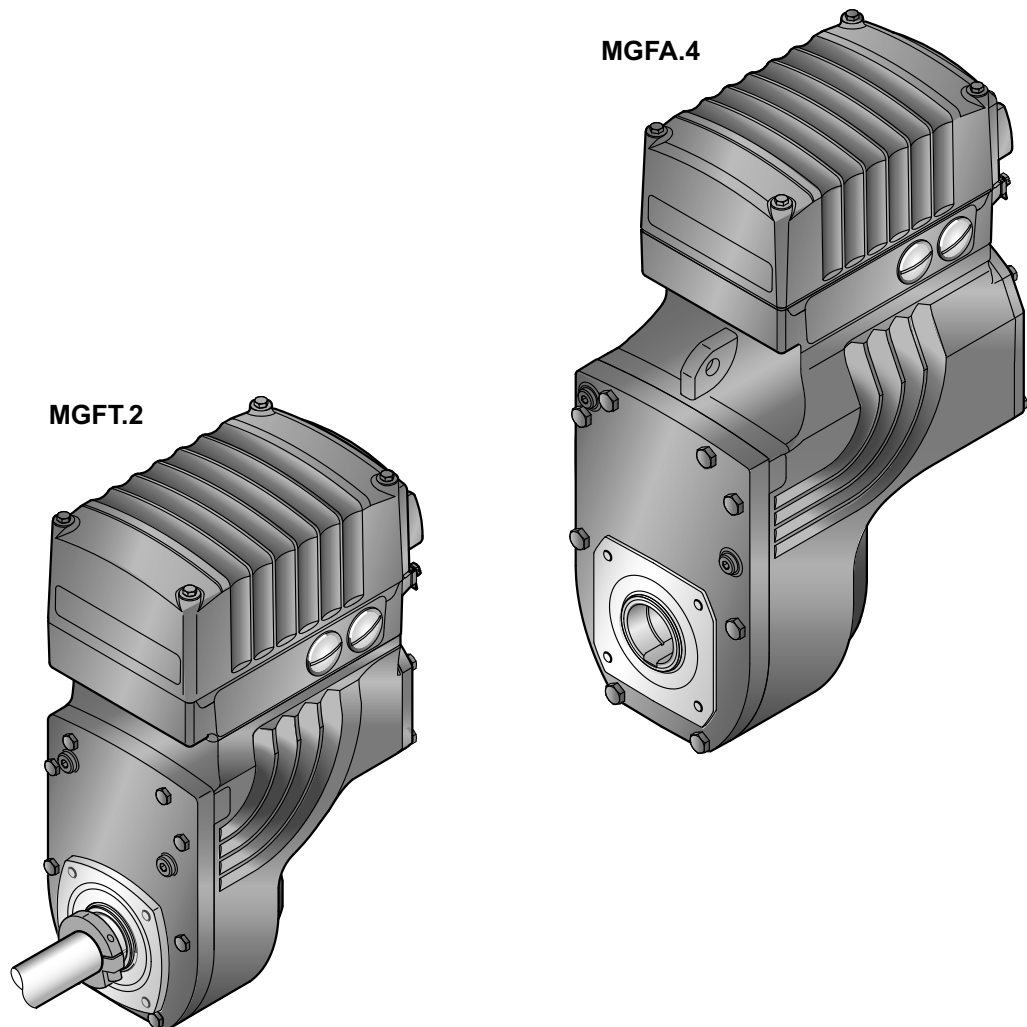

7

744442251

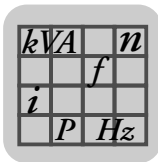

7.2.2 MOVIGEAR® load profile

The MOVIGEAR® drive unit is specifically designed to match the requirements of horizontal conveyor applications. The following figure shows typical load characteristics.

Refer to the following table for the exact values regarding the static breakaway torque and the continuous torque of the drive units.

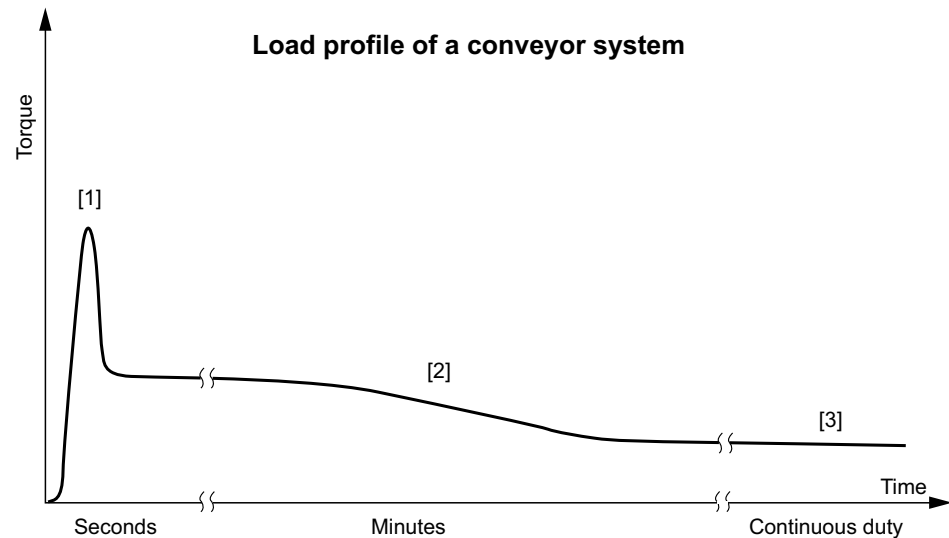

174348043

MOVIGEAR® type	Operating range [1] (static breakaway torque, 5 s)	Operating range [2] (5 min.)	Operating range [3] (duration)
MGF.2	350 % M_a	200 % M_a	100 % M_a
MGF.4	350 % M_a	200 % M_a	100 % M_a

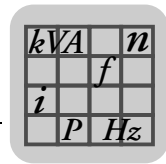

7.2.3 Selecting MOVIGEAR®-SNI

The following figure shows schematic characteristic curves for the maximum torque ($M_{\max \text{ startup}}$) and the output torque (M_a) in S1 operation. The tables below list the exact values..

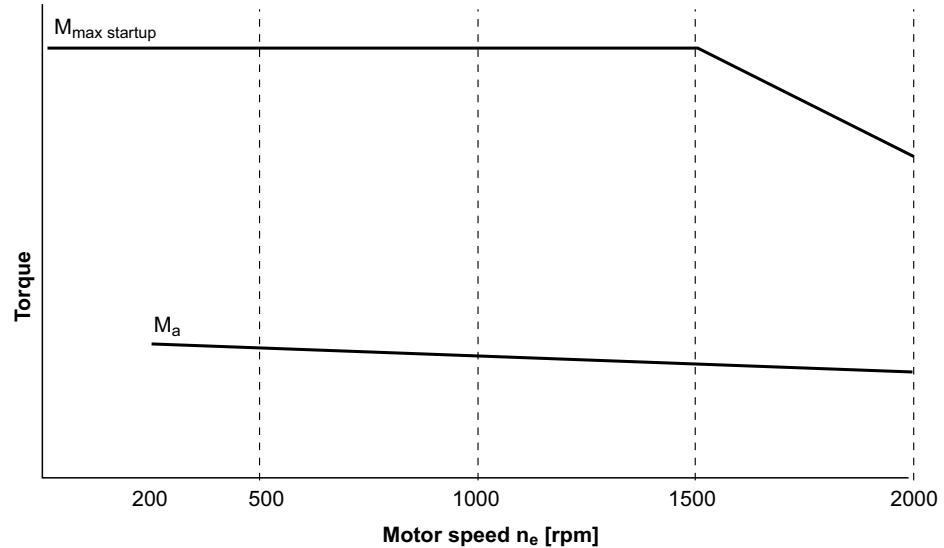

889614987

MGF..2										
	n_a		M_a				M_{gdf}	$M_{\max \text{ startup}}$	i_{tot}	Weight
	with $n_e=200$ rpm	with $n_e=2000$ rpm	with $n_e=500$ rpm	with $n_e=1000$ rpm	with $n_e=1500$ rpm	with $n_e=2000$ rpm				
	[rpm]	[rpm]	[Nm]	[Nm]	[Nm]	[Nm]	[Nm]	[Nm]		[kg]
3-stage	3.6	36.2	200	200	197	197	200	500 ¹⁾	55.25	16.0
	5.4	53.7	147	140	133	133	200	500 ¹⁾	37.24	
2-stage	10.8	108.0	74	71	67	67	192	281 ¹⁾	18.52	15.7
	20.6	206.0	39	37	35	35	152	147	9.71	
	40.0	400.0	20	19	18	18	94	76	5.00	

1) Permitted frequency of occurrence, on request

MGF..4										
	n_a		M_a				M_{gdf}	$M_{\max \text{ startup}}$	i_{tot}	Weight
	with $n_e=200$ rpm	with $n_e=2000$ rpm	with $n_e=500$ rpm	with $n_e=1000$ rpm	with $n_e=1500$ rpm	with $n_e=2000$ rpm				
	[rpm]	[rpm]	[Nm]	[Nm]	[Nm]	[Nm]	[Nm]	[Nm]		[kg]
3-stage	4.2	41.7	309	309	309	309	388	1000 ¹⁾	48.00	24.0
2-stage	7.8	77.8	169	169	169	169	400	616 ¹⁾	25.72	23.6
	15.8	158.0	83	83	83	83	323	303	12.66	
	31.6	315.5	42	42	42	42	212	152	6.34	

1) Permitted frequency of occurrence, on request

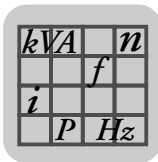

7.2.4 Selecting MOVIGEAR®-SNI with extended control range

The following figure shows schematic characteristic curves for the maximum torque ($M_{\max \text{ startup}}$) and the output torque (M_a) in S1 operation. The tables below list the exact values..

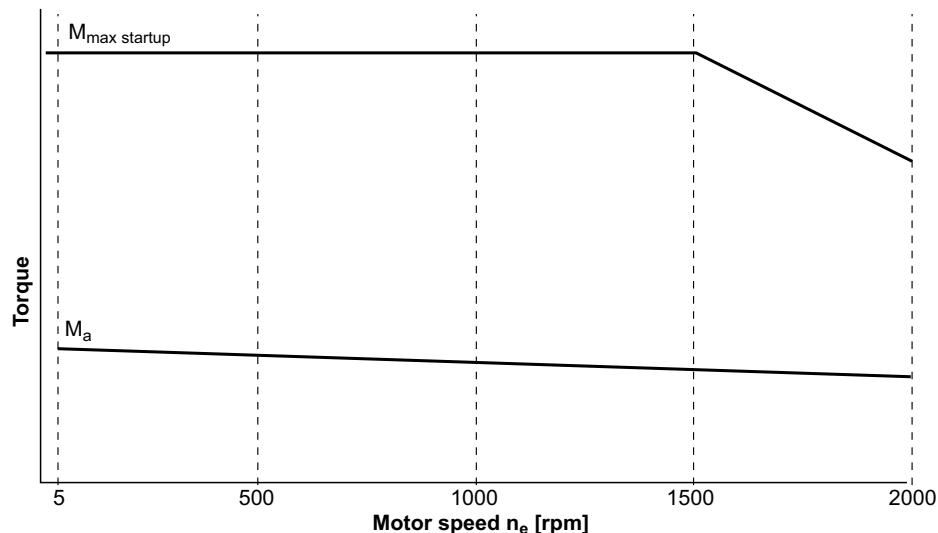

1677276299

	n_a		$M_a^{1)}$					M_{gdf}	$M_{\max \text{ startup}}^{2)}$	i_{tot}	Weight
	with $n_e = 1$ rpm	with $n_e = 2000$ rpm	with $n_e = 5$ rpm	with $n_e = 500$ rpm	with $n_e = 1000$ rpm	with $n_e = 1500$ rpm	with $n_e = 2000$ rpm				
	[rpm]	[rpm]	[Nm]	[Nm]	[Nm]	[Nm]	[Nm]	[Nm]	[Nm]		[kg]
3-stage	0.02	36.2	200	200	200	197	197	200	500 ²⁾	55.25	16.0
	0.03	53.7	147	147	140	133	133	200	500 ²⁾	37.24	
2-stage	0.05	108.0	74	74	71	67	67	192	281 ²⁾	18.52	15.7
	0.10	206.0	39	39	37	35	35	152	147	9.71	
	0.20	400.0	20	20	19	18	18	94	76	5.00	

1) For motor speeds $n_e < 5$ rpm, you have to reduce the output torque M_a by factor 0.9.

2) Permitted frequency of occurrence on request.

	n_a		$M_a^{1)}$					M_{gdf}	$M_{\max \text{ startup}}^{2)}$	i_{tot}	Weight
	with $n_e = 1$ rpm	with $n_e = 2000$ rpm	with $n_e = 5$ rpm	with $n_e = 500$ rpm	with $n_e = 1000$ rpm	with $n_e = 1500$ rpm	with $n_e = 2000$ rpm				
	[rpm]	[rpm]	[Nm]	[Nm]	[Nm]	[Nm]	[Nm]	[Nm]	[Nm]		[kg]
3-stage	0.02	41.7	309	309	309	309	309	388	1000 ²⁾	48.00	24.0
2-stage	0.04	77.8	169	169	169	169	169	400	616 ²⁾	25.72	23.6
	0.08	158.0	83	83	83	83	83	323	303	12.66	
	0.16	315.5	42	42	42	42	42	212	152	6.34	

1) For motor speeds $n_e < 5$ rpm, you have to reduce the output torque M_a by factor 0.9.

2) Permitted frequency of occurrence on request.

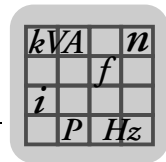

7.3 Sample unit designation

The following table shows the MOVIGEAR®-SNI unit designation:

SEW-EURODRIVE			
76646 Bruchsal/Germany			
MGFAT2-DSM-SNI	M _{max.} 500 Nm		
01.1233697403.0001.08	M _A 133 Nm	IP 65	
IM M1,M2,M5,M6	f _N 50...60 Hz	cos φ 0,99	
i 37,24 °C 0... +40	U _N 380...500 V	A 1,53	
	n _A 5,4...53,7 r/min	n _R 1/10	
3~ IEC60034	kg 16.000	1883186	
CLP HC 220 Synth.Öl/0,55l	Made in Germany		

1533246859

MGFAS2-DSM-SNI

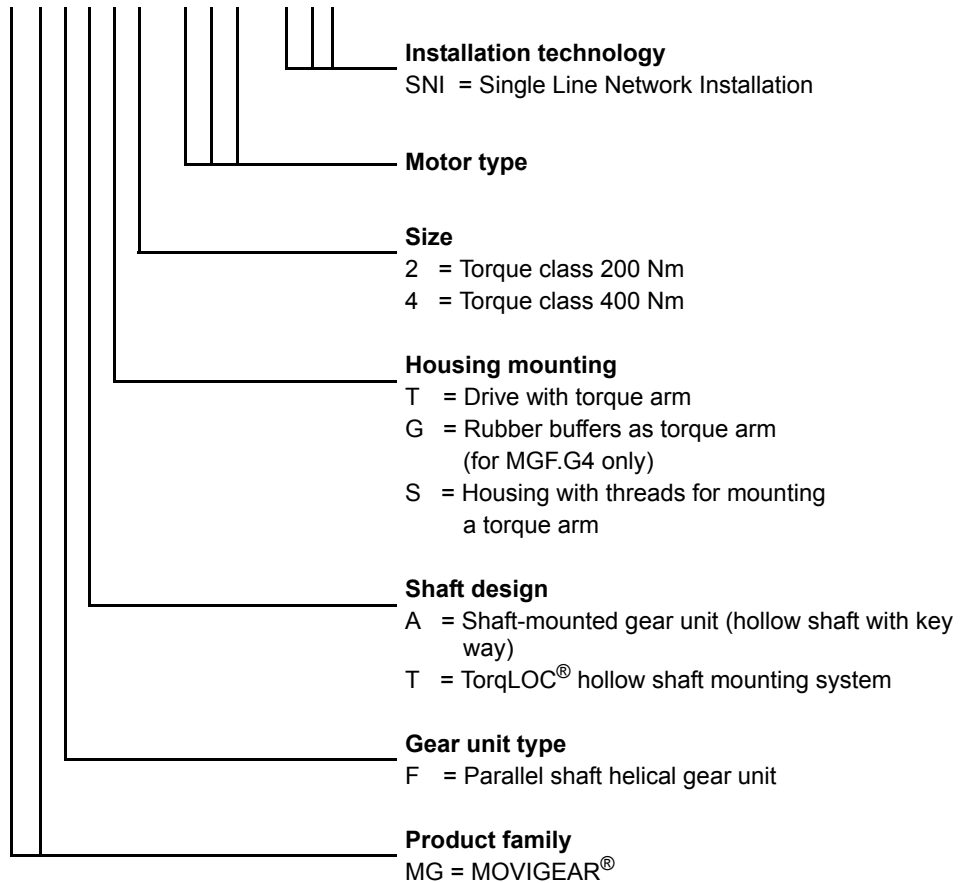

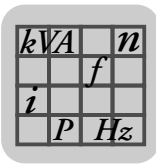

7.4 Options

7.4.1 DynaStop® – the electrodynamic deceleration function

Dynastop® allows for creating a speed-dependent torque when the motor is de-energized or "controller inhibit" is activated. This prevents the application from over accelerating due to external forces (e.g. sagging on inclining tracks)

The MOVIGEAR® has the following function when the drive is running: In the event of a voltage failure, the kinetic energy is used to supply the frequency inverter via regeneration. This allows for a controlled deceleration process.

DynaStop® is activated when the regenerative power is insufficient.

The electrodynamic deceleration function, DynaStop® does not allow for a definite stop at a position:

- The electrodynamic deceleration function must not be used for hoists.
- For ascending sections, DynaStop® must only be used following a risk analysis.

7.4.2 Electronics design

The electronics cover of MOVIGEAR®-SNI is available in the following designs:

- Electronics cover without application slot
- Electronics cover with application slot

The following figure shows the possible designs:

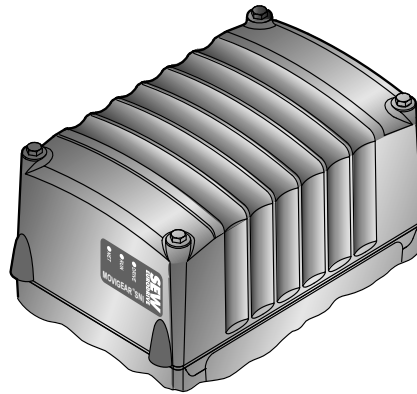

**MOVIGEAR® electronics cover
without application slot**

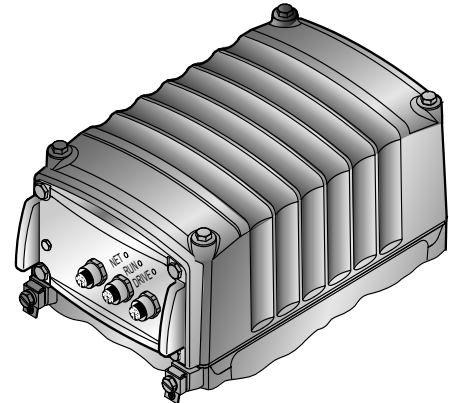

**MOVIGEAR® electronics cover
with application slot
(in this case with GIO12A option)**

744771083

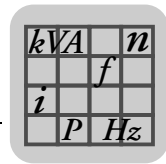

7.4.3 GIO12A application GIO12A

The following figure shows the GIO12A application option:

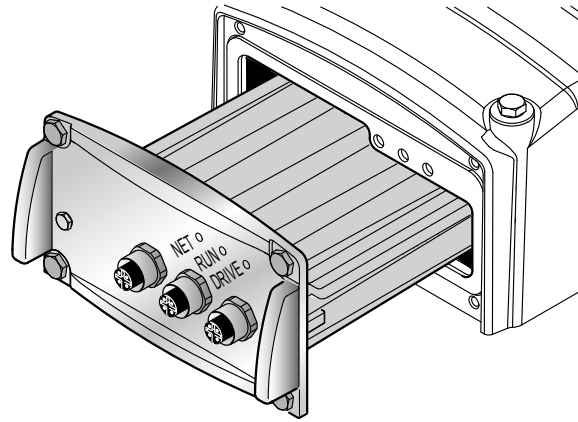

744796043

7

The GIO12A application option allows for controlling up to 2 digital actuators and processing up to 4 digital sensors. The energy supply of the option and the communication between MOVIGEAR®-SNI and the option are both contactless.

Unit designation

The following table shows the unit designation for the available application options:

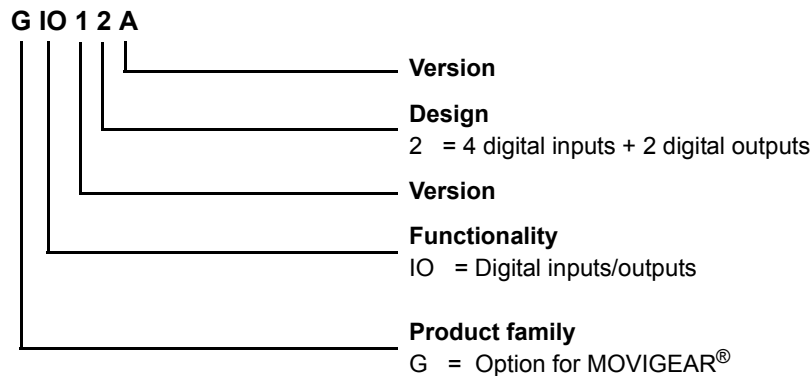

7.4.4 MOVIGEAR®-SNI extended control range.

This design allows for operating MOVIGEAR®-SNI drive units with an extended control range (speed range from 1 rpm to 2000 rpm)

For additional information refer to section "Selecting MOVIGEAR®-SNI with extended control range" (see page 190).

Take into account that with "extended control range" the contour dimensions of the MOVIGEAR®-SNI drive units change. For additional information refer to section "Selecting MOVIGEAR®-SNI with extended control range".

Required order information: Extended control range

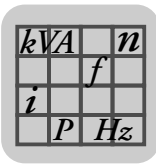

7.4.5 Package for wet areas

MOVIGEAR® drive units with the optional package for wet areas have the following characteristics:

- [1] Terminal box with cable outlet on one end
- [2] Pre-installed EMC cable glands (M25) brass nickel-plated
- [3] OS4 surface protection
- [4] Additional cover opposite the output side
- [5] Installed and activated breather valve corresponding to the mounting position,
- [6] Pre-installed pressure compensation fitting (M16) in conjunction with mounting positions M1, M3, M5, M6
- [7] Pre-installed pressure compensation fitting (M16) in conjunction with M2, M4

For further information, refer to the "MOVIGEAR®-SNI" system manual.

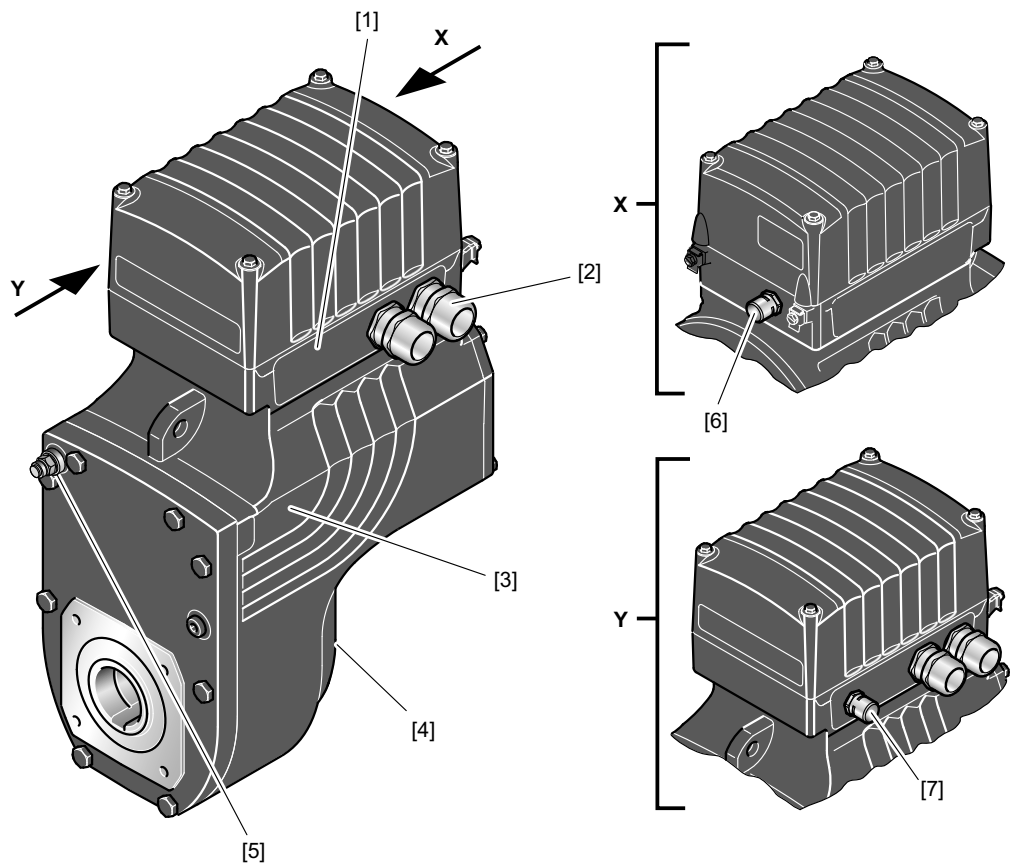

842977035



In SEW publications, all illustrations regarding MOVIGEAR® drive units with optional package for wet areas are displayed with a shading (= OS4 surface protection).